

Heavy Ion Measurements with the ATLAS Detector at the LHC

Brian A. Cole, Columbia University

June 28, 2007

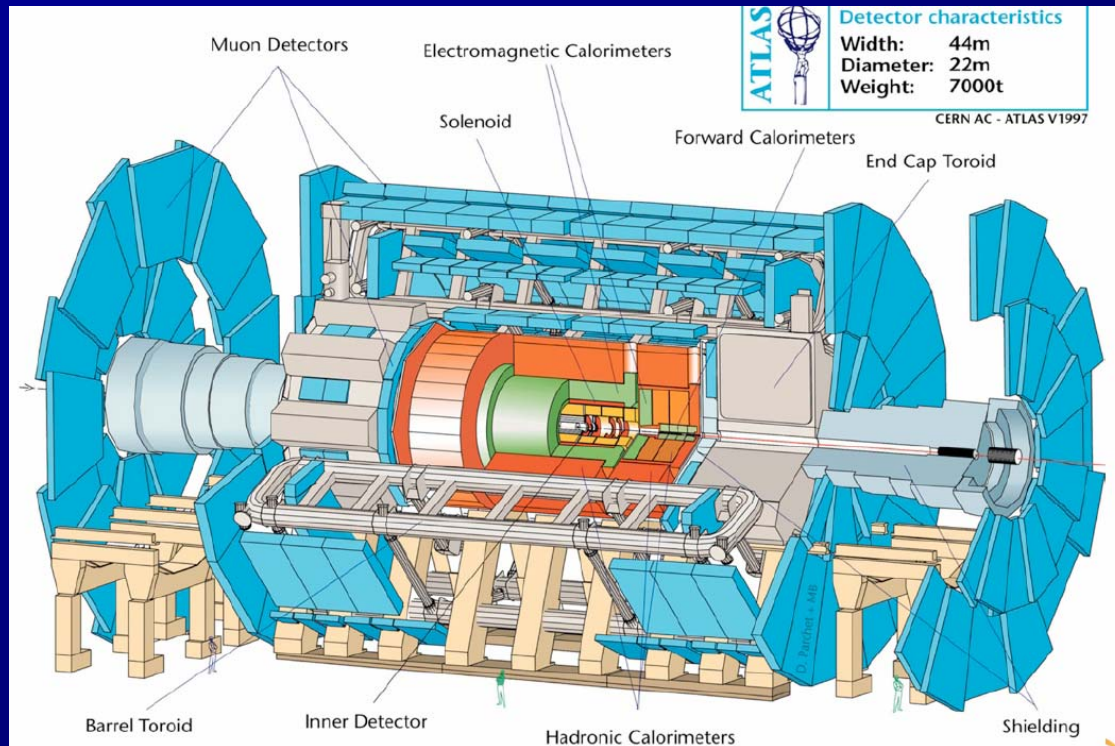

LHC Heavy Ion Program: Key Questions

- **What is the mechanism for initial particle production at the LHC?**
 - Production from a saturated initial state?
- **How rapidly do produced particles thermalize or isotropize, what is the mechanism?**
 - Faster than RHIC, slower ?
- **How do high-energy quarks and gluons interact in the quark gluon plasma?**
 - What is the response of the medium?
- **What is the screening length of the QGP?**
- **What are the quasi-particles of the QGP?**
- **How does the QGP hadronize?**

LHC Heavy Ions Program: Key Questions

- **What is the mechanism for initial particle production at the LHC?**
 - Production from a saturated initial state?
- **How rapidly do produced particles thermalize or isotropize, what is the mechanism?**
 - As fast as at RHIC or not?
- **How do high-energy quarks and gluons interact in the quark gluon plasma?**
 - What is the response of the medium?
- **What is the screening length of the QGP?**
- **What are the quasi-particles of the QGP?**
- **How does the QGP hadronize?**



LHC Heavy Ions Program: Key Questions

- How do high-energy quarks and gluons interact in the quark gluon plasma?
 - What is the response of the medium?

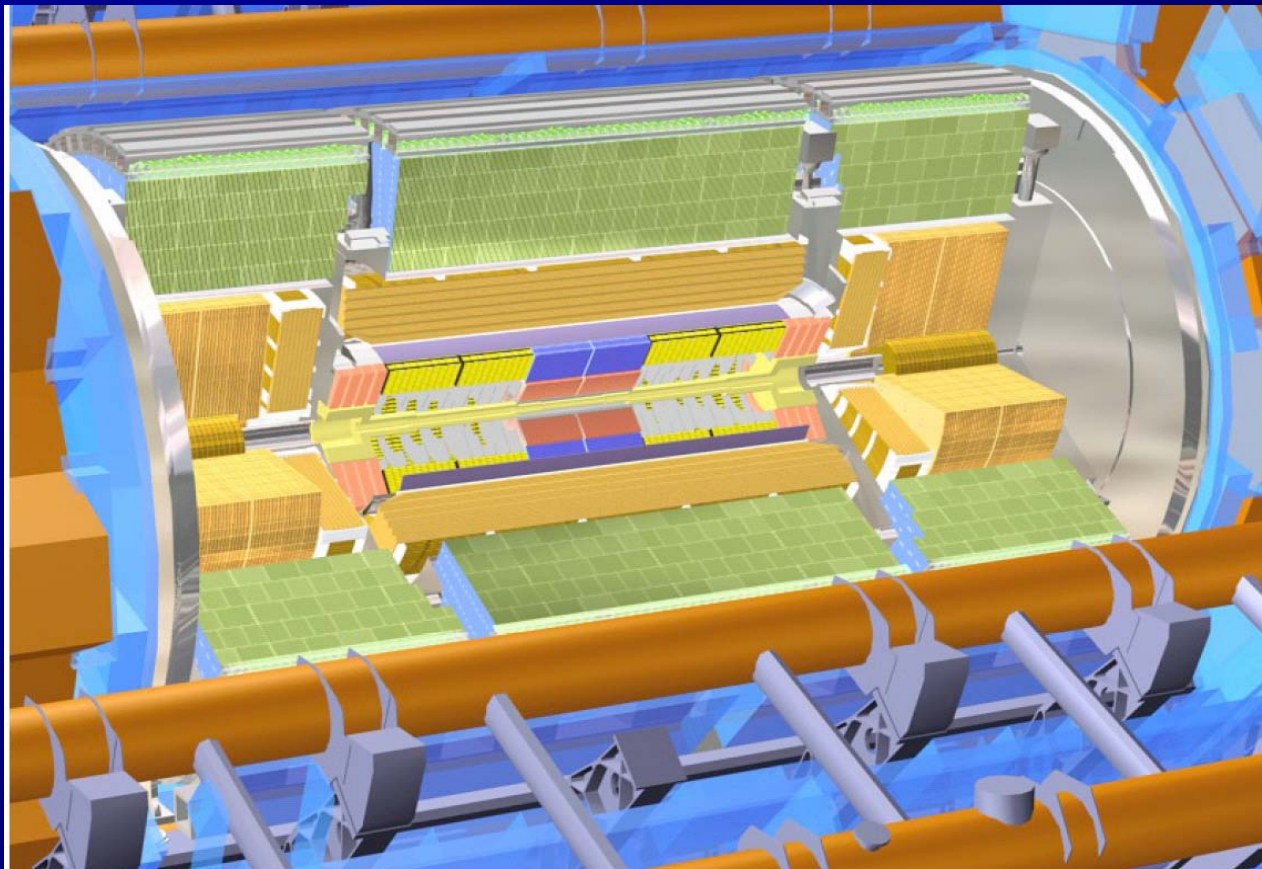

LHC Physics Summary

Parton Density

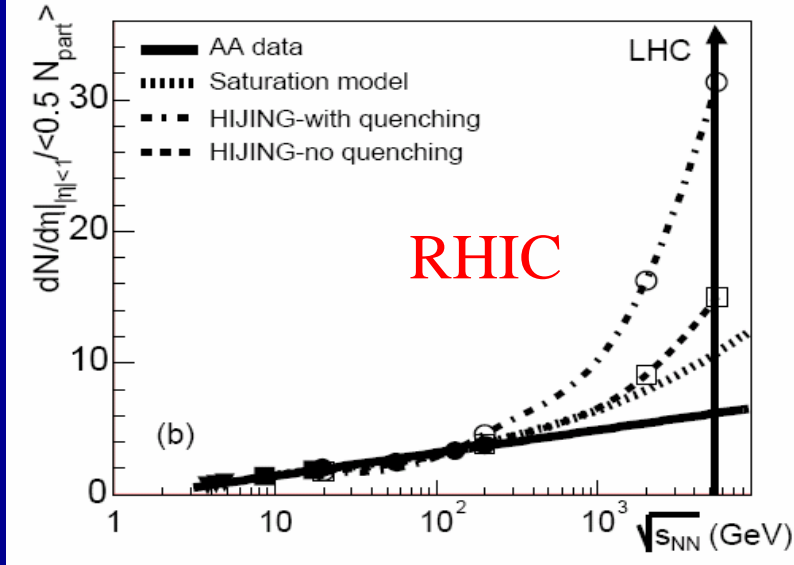

Collectivity

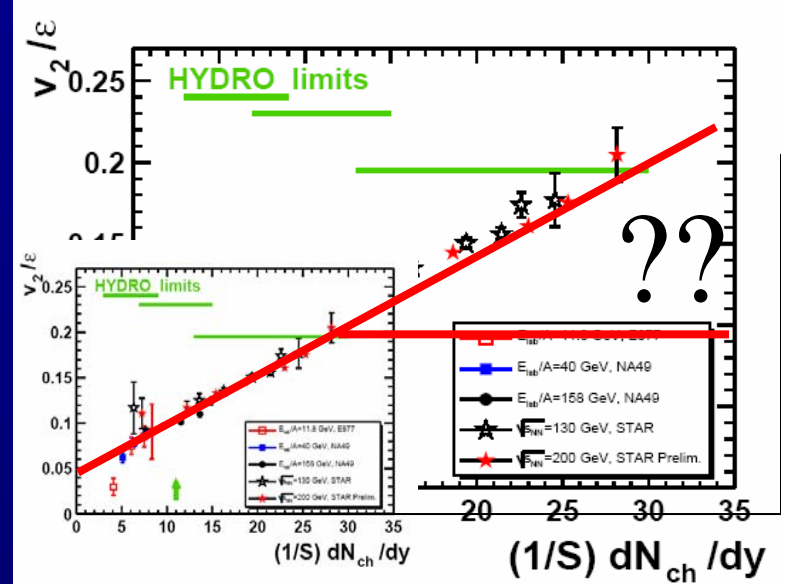

High p_T

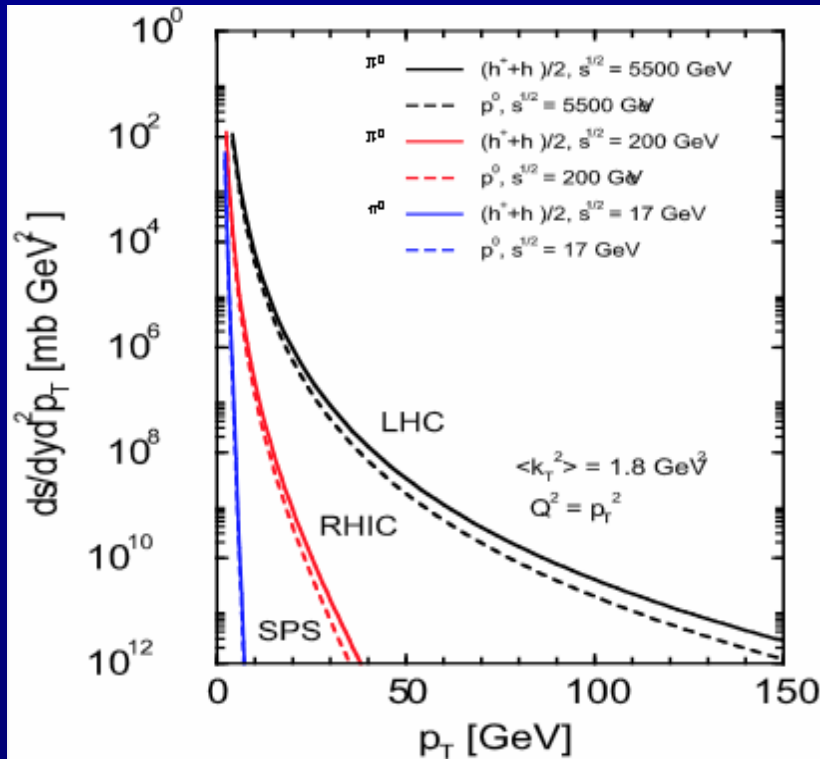

Low X

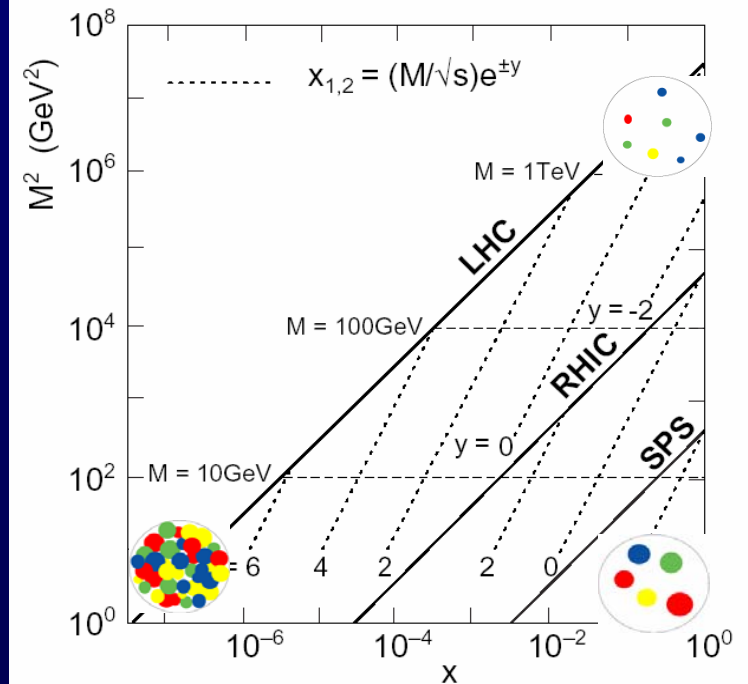

Jet Tomography

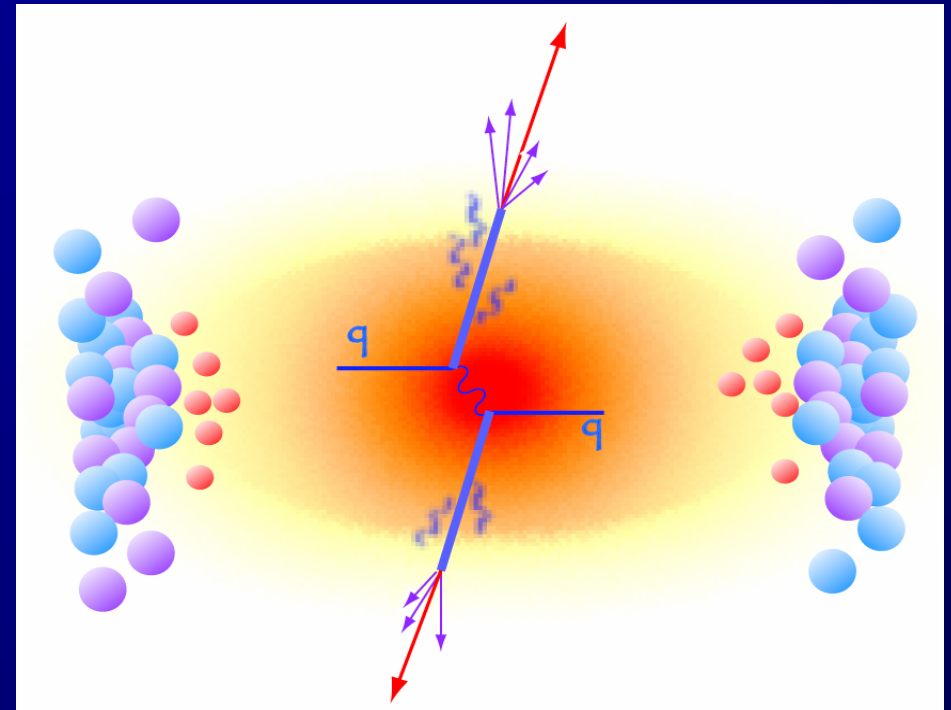
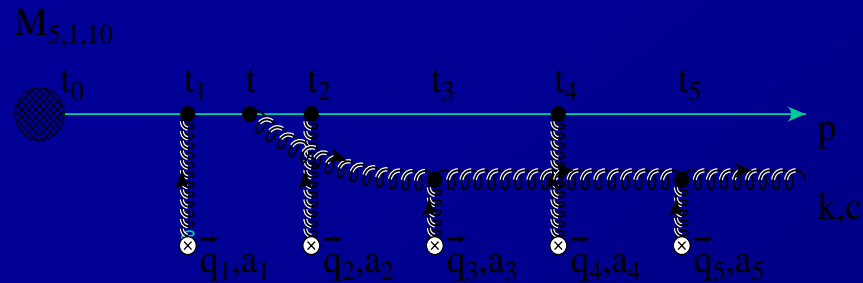

- **At RHIC, studied via leading hadrons**

- Statistics suffer from frag. function \Rightarrow **rates**
- Quenching \Rightarrow **geometric bias**
- No direct measure of frag. function.

- **At LHC:**

- **Full jets, high p_T , large rates, b jets, di-jet, γ -jet**
 \Rightarrow **Precision jet tomography**

Jet Tomography

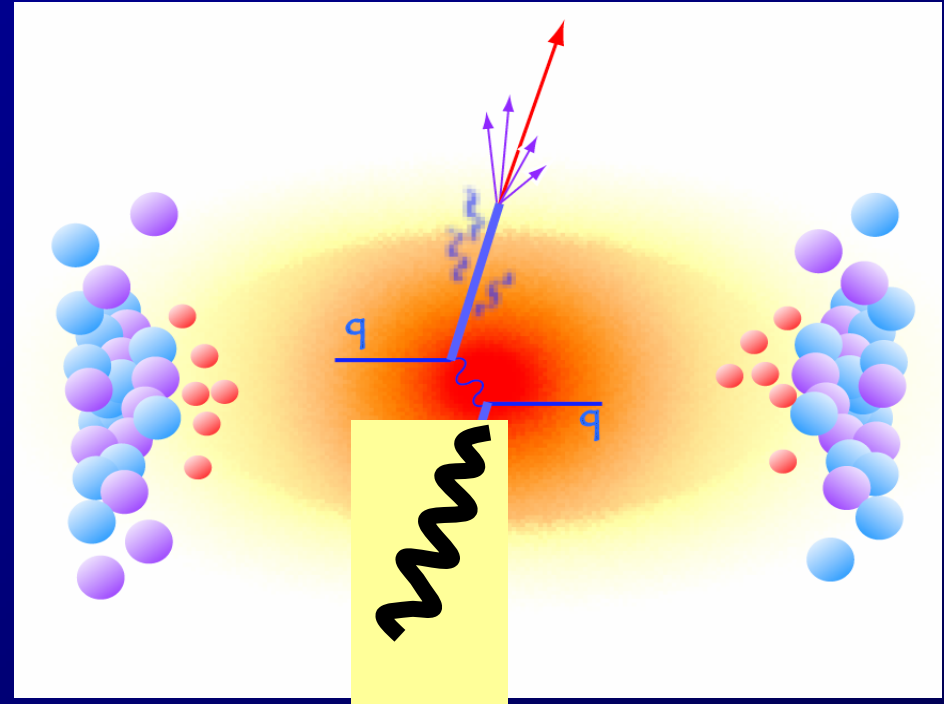
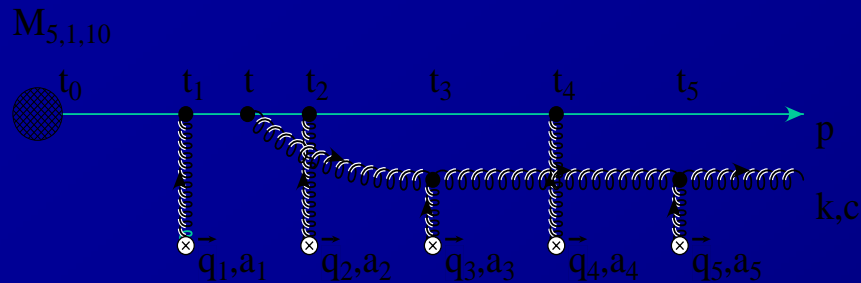

- **At RHIC, studied via leading hadrons**

- Statistics suffer from frag. function \Rightarrow **rates**
- Quenching \Rightarrow **geometric bias**
- No direct measure of frag. function.

- **At LHC:**

- Full jets, high p_T , large rates, b jets, di-jet, γ -jet
- \Rightarrow **Precision jet tomography**

Parton Showers, Hard Radiation @ LHC

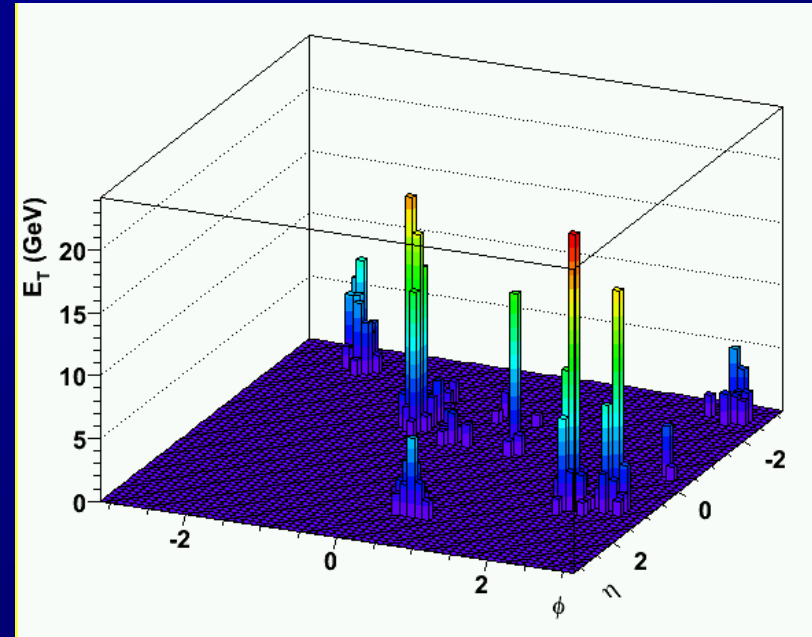
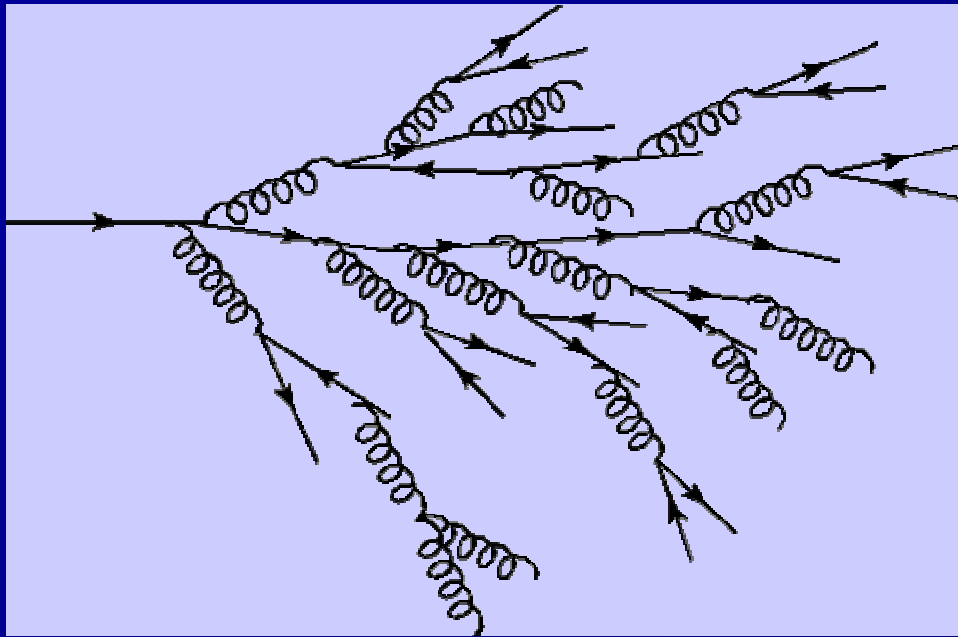

- **Copious hard radiation in high Q^2 final-state parton showers, $\tau_F \sim 1/k_T$**
- **Both an opportunity and a challenge**
 - Understanding jet quenching more difficult
 - Potentially: time-dependent probe of medium
- **Resolving hard radiation in jets a must!**

The ATLAS Central Detector

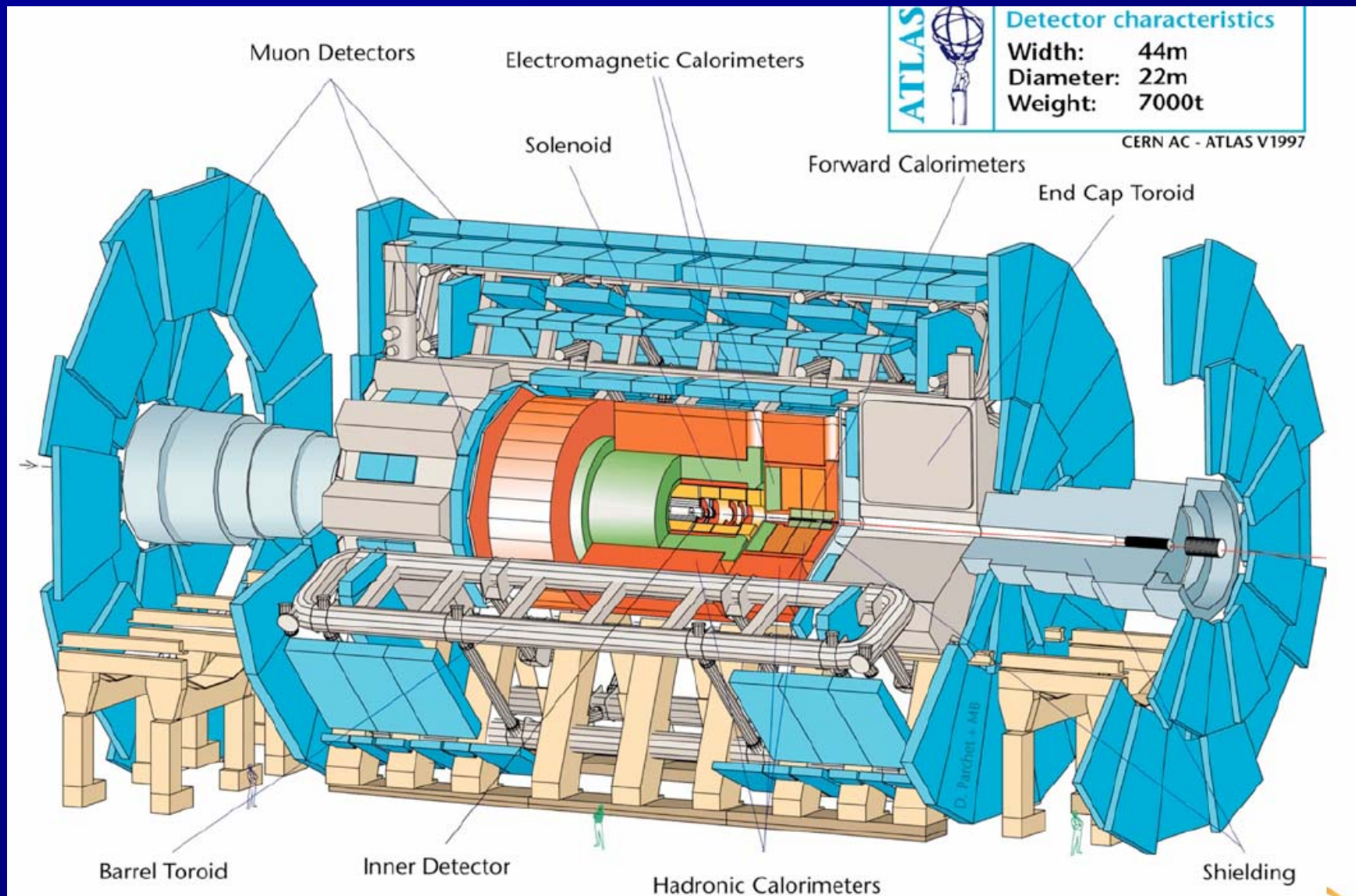

- Inner tracking, EM and Hadronic calorimeters, external muon spectrometers

ATLAS from the Inside



UX15 Jura Wed Jun 20 04:00:02 2007

UX15 Geneva Wed Jun 20 04:00:01 2007

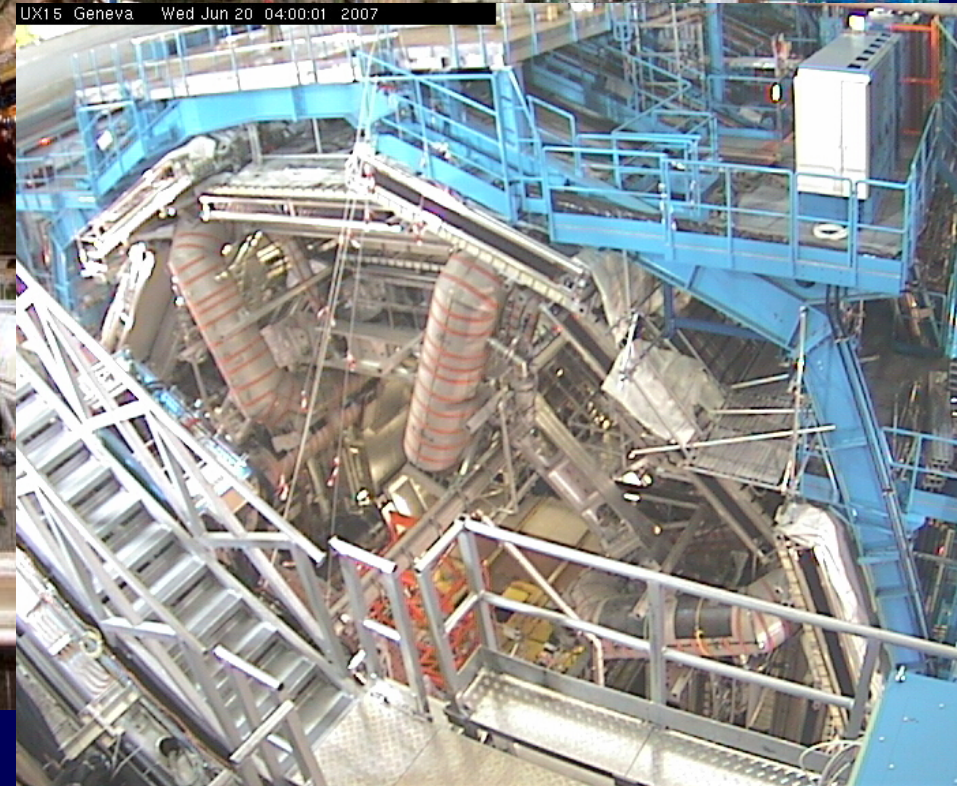
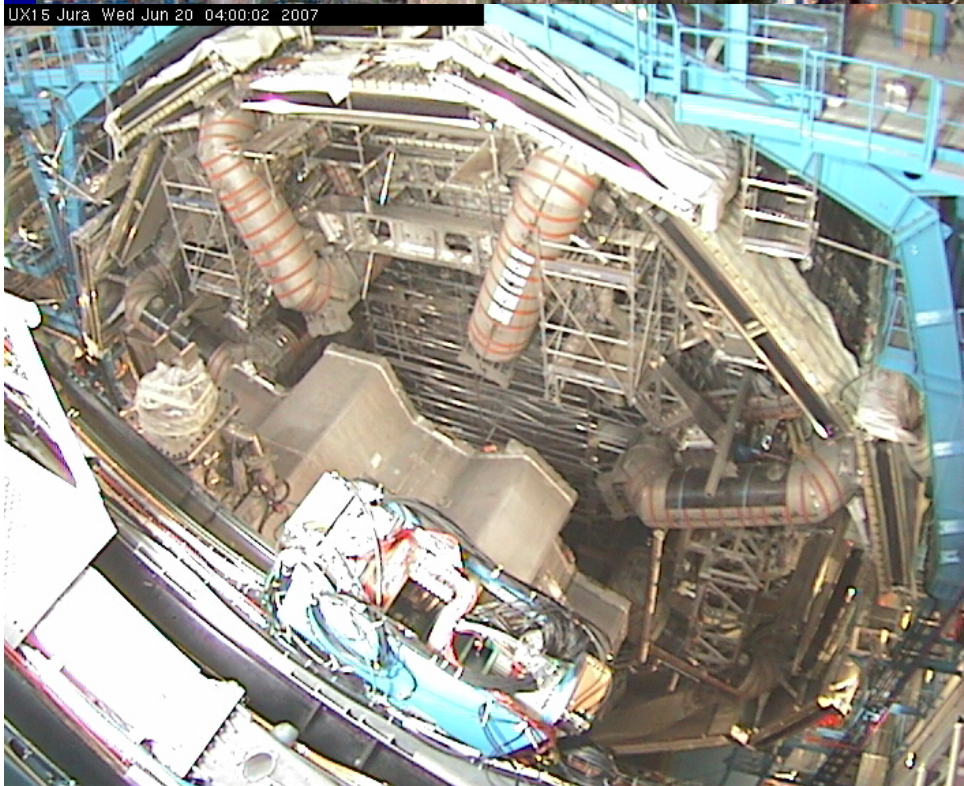

ATLAS Zero Degree Calorimeter

TAN region, $z=140\text{m}$

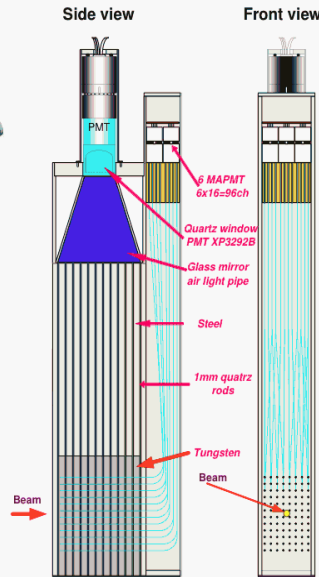
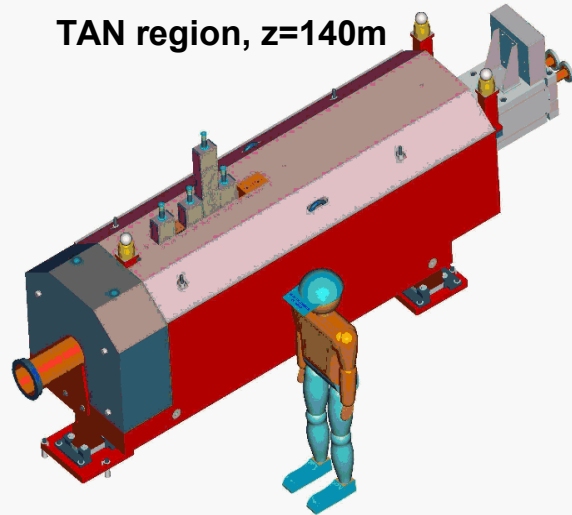

230-GeV protons. 20-cm steel before ZDC-module.

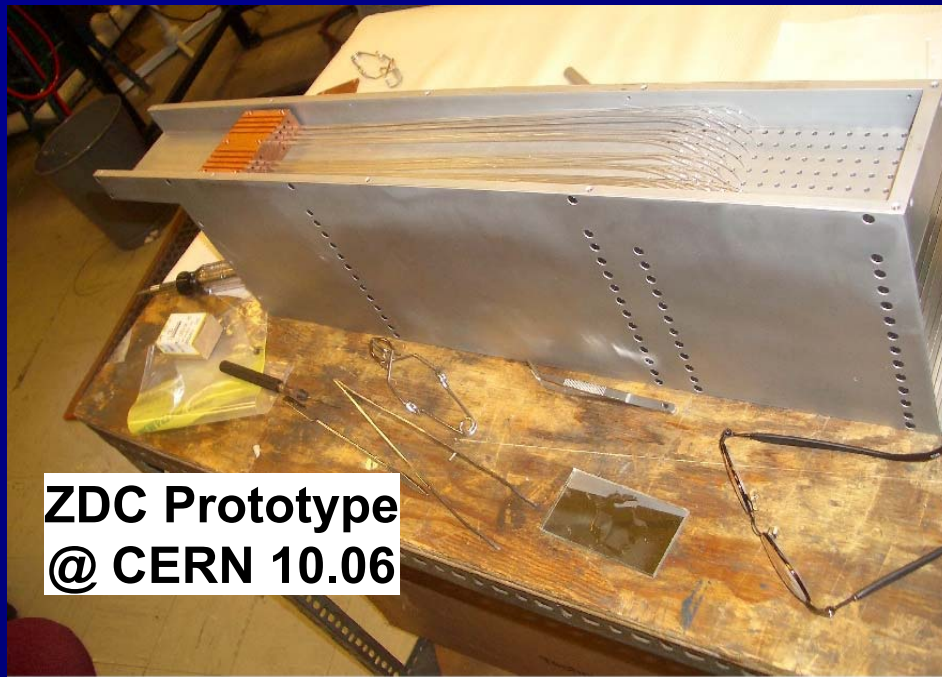
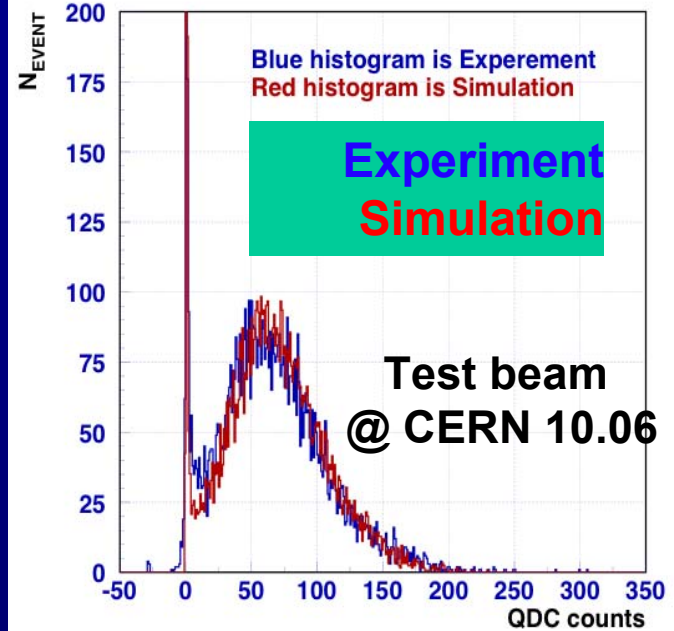

$p+p$ events, w/ precision EM module

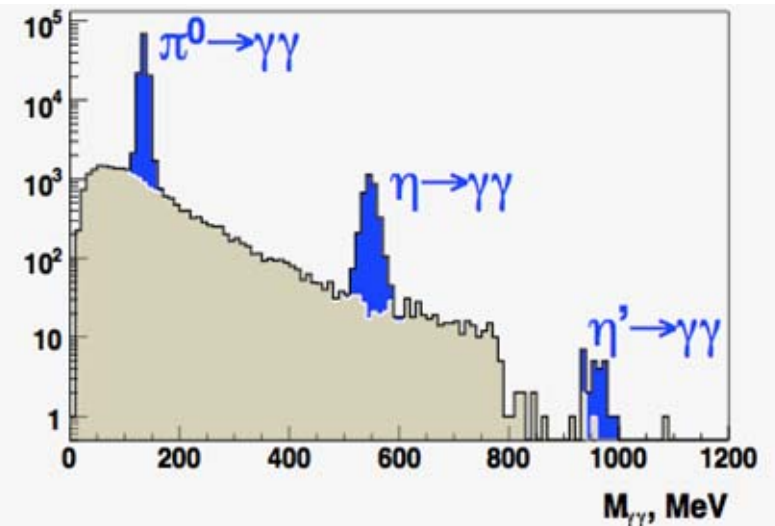

ATLAS Acceptance

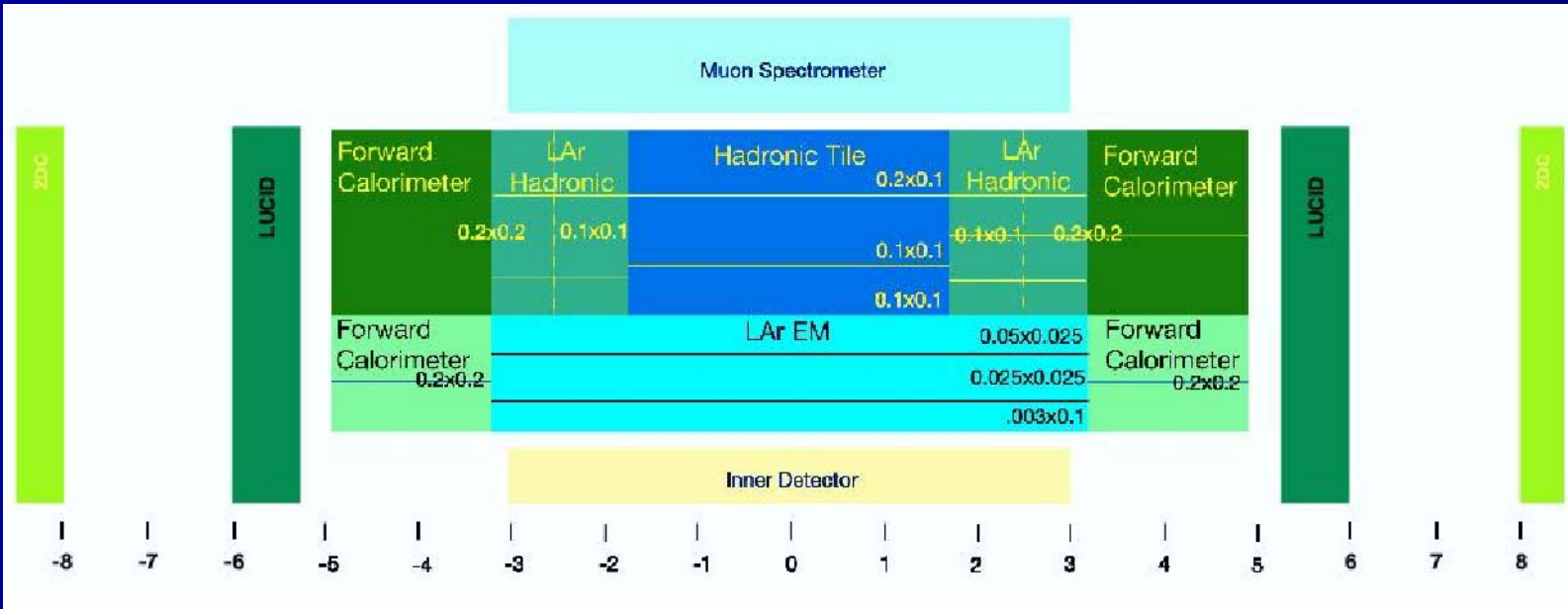

ATLAS Acceptance

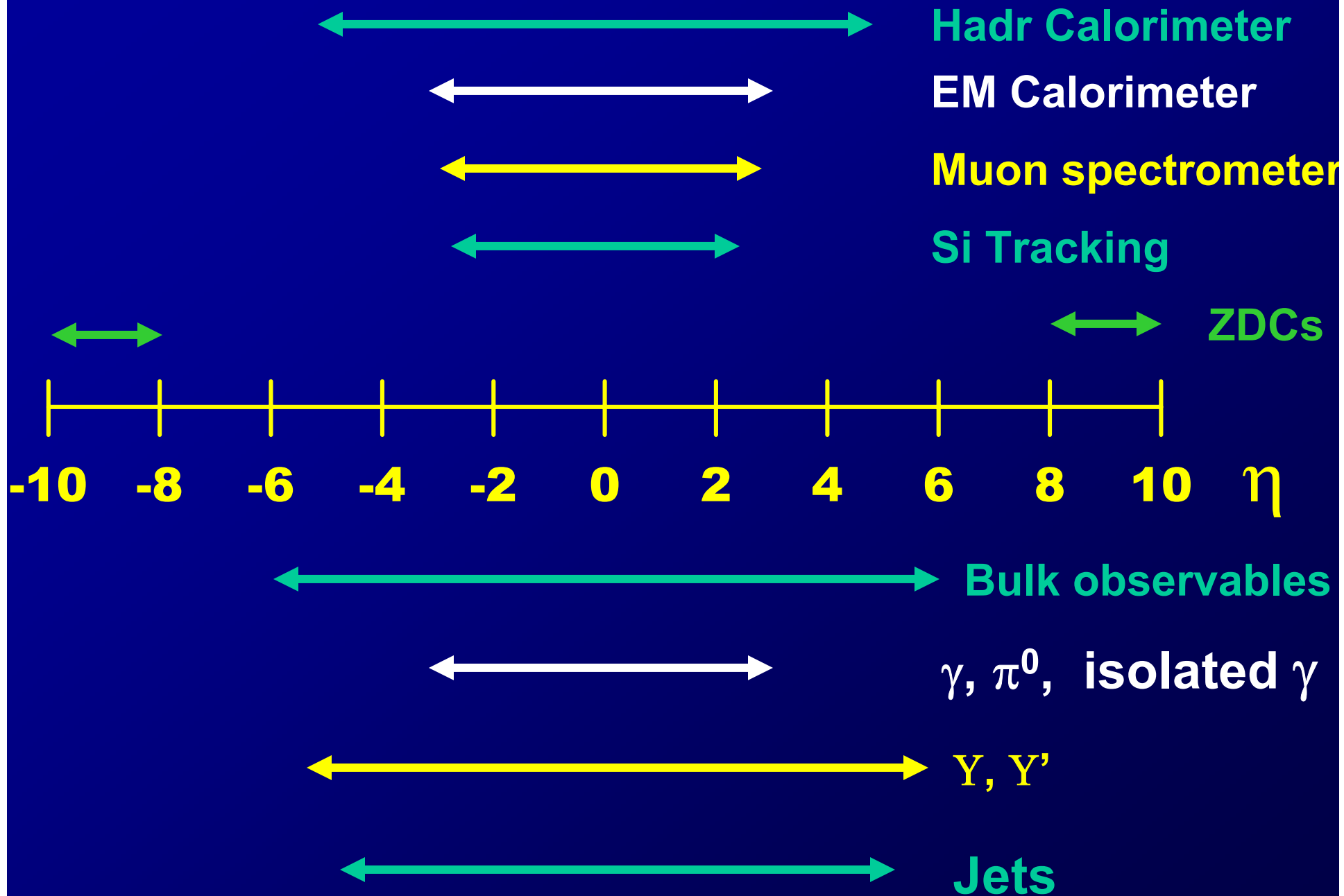

ATLAS Acceptance

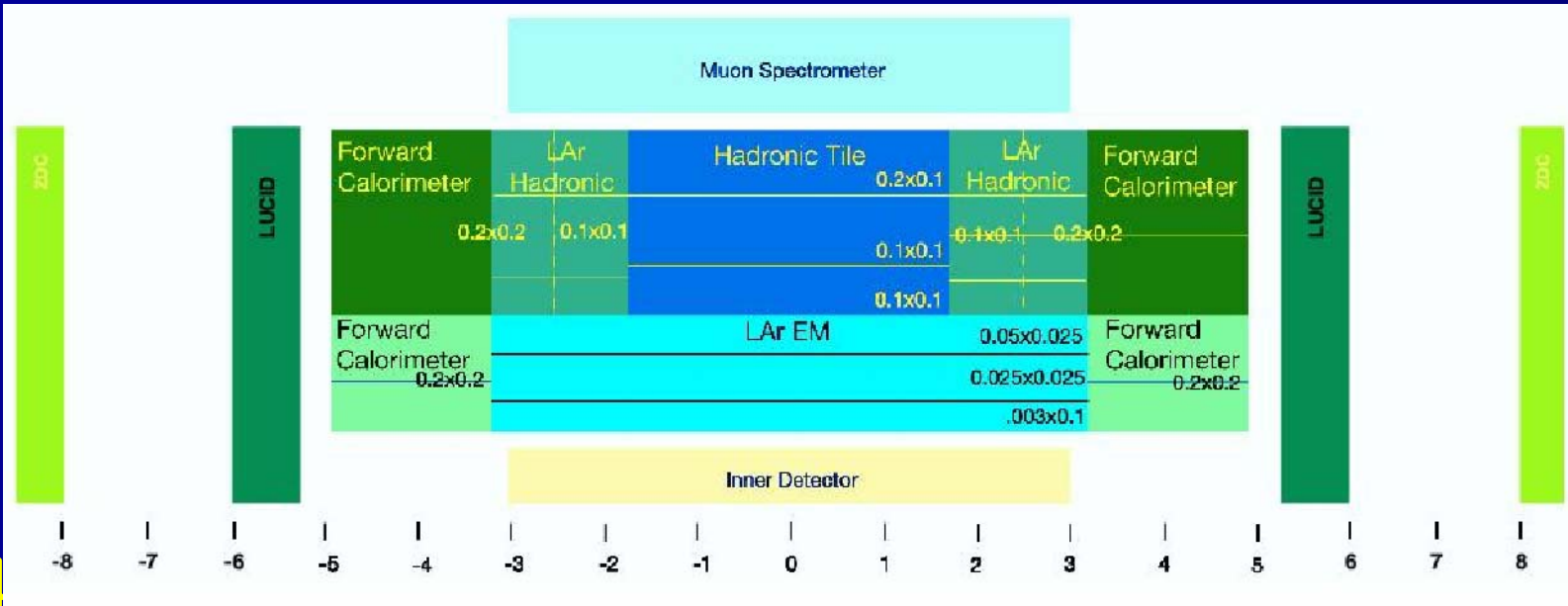

-10 -8 -6 -4 -2 0 2 4 6 8 10 η

← Bulk observables →

← →

γ , π^0 , isolated γ

← →

Y , Y'

← →

Jets

ATLAS Inner Tracker & Tracking

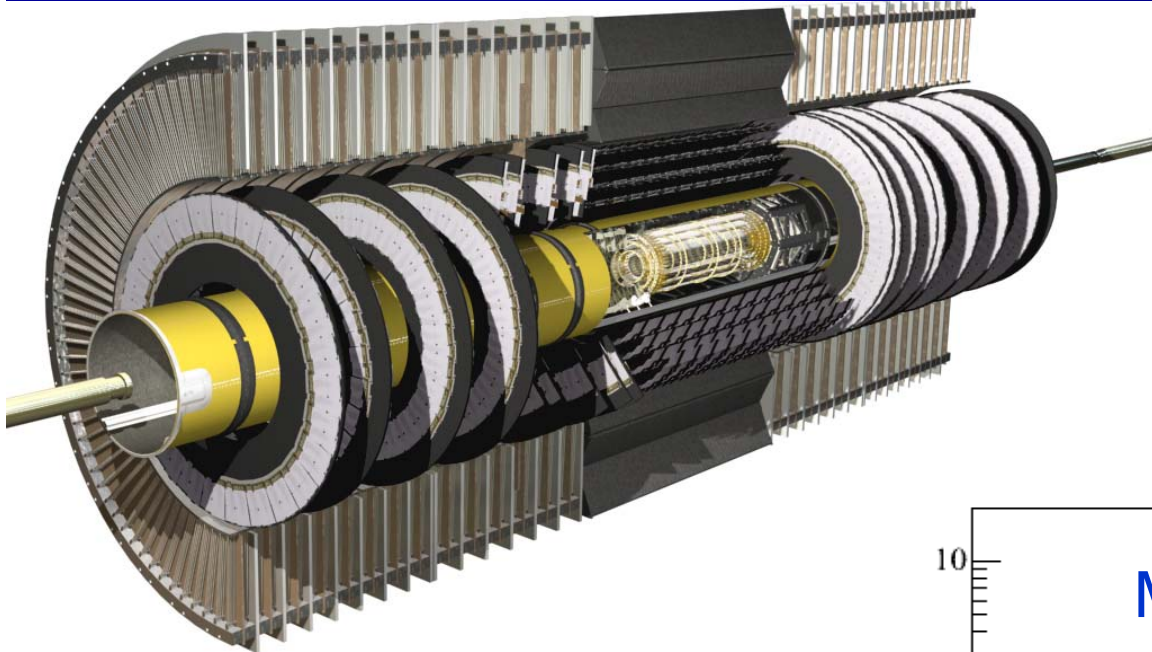

- 3 layers Si pixel
- 8 layers Si strip
- TR tracker

- “Vanilla” ATLAS track reconstruction
 - But with only Si detectors
- Tuned parameters **but**
 - No η dependence to tracking cuts (**yet**)
 - No verification with calorimeter clusters (**here**)

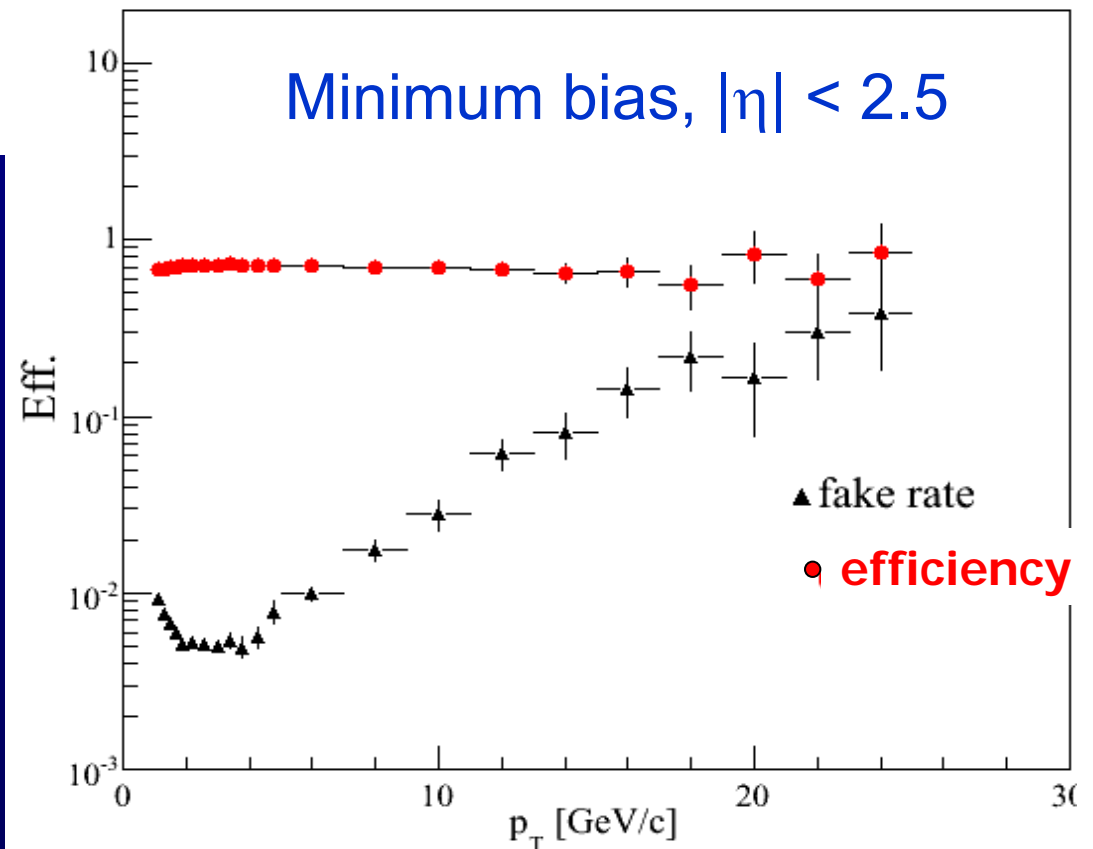

ATLAS Tracking

Fake track fraction

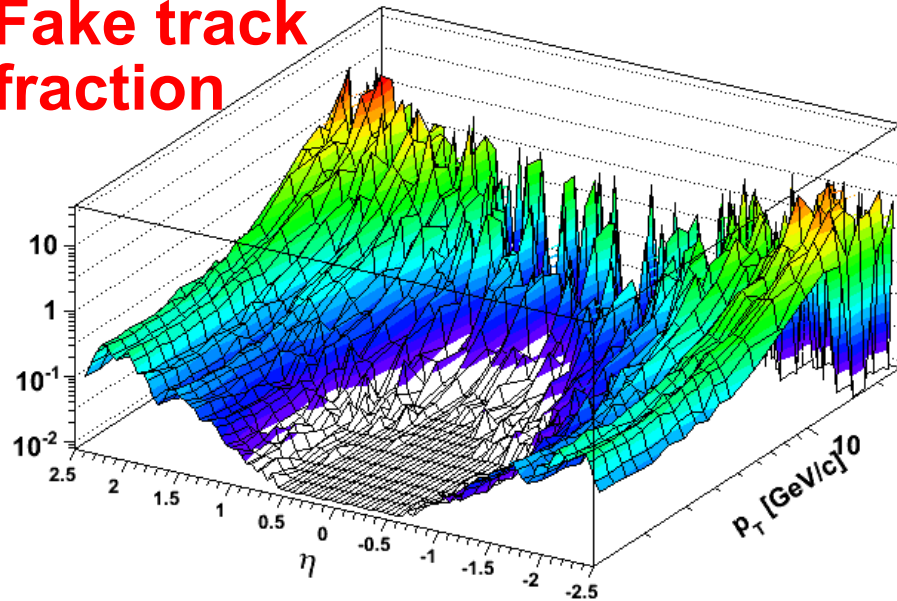

- High fake track rates for $|\eta| > 2$.
 - Increasing hit density
 - Material in Si tracker
- ⇒ More work needed
⇒ e.g. tighter cuts @ larger η

- For $|\eta| < 1$, central Pb+Pb ($b = 2.3$ fm)
 - Excellent results using “vanilla” ATLAS track reconstruction

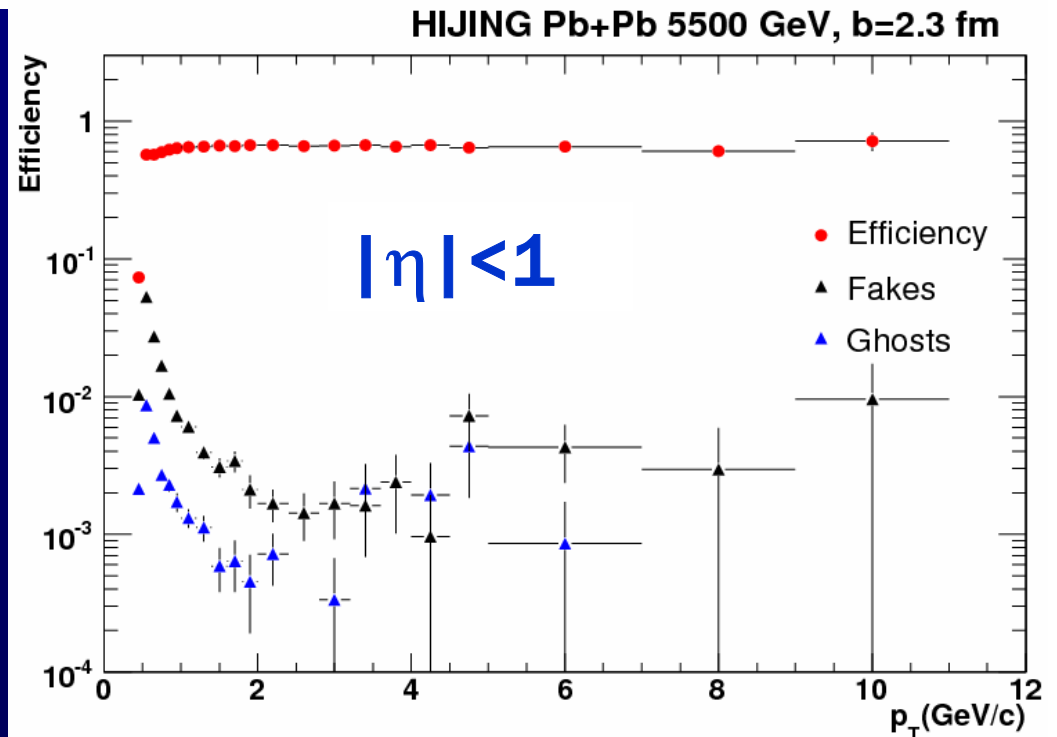

ATLAS Calorimetry

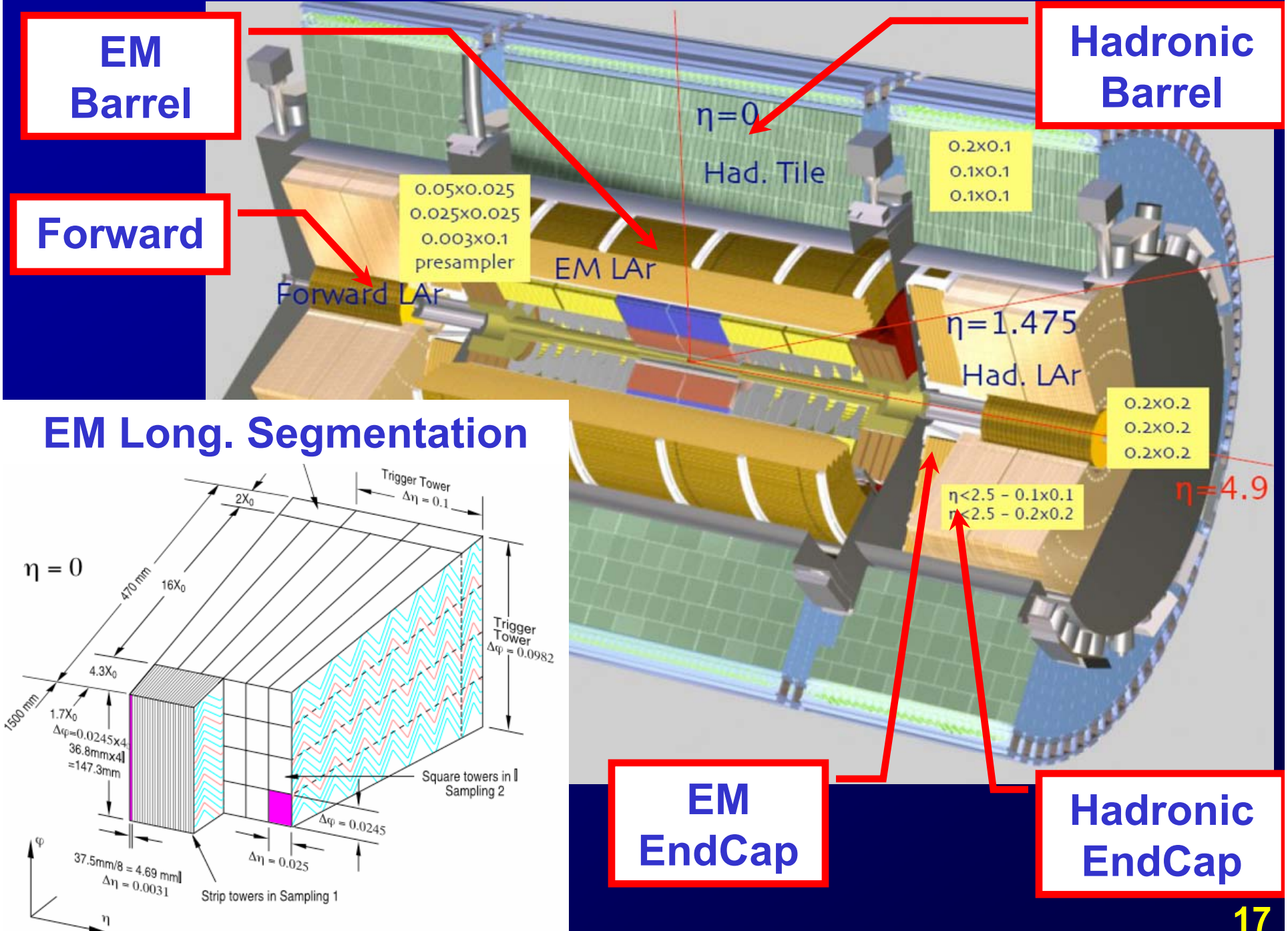

EM Calorimeter Long. Segmentation

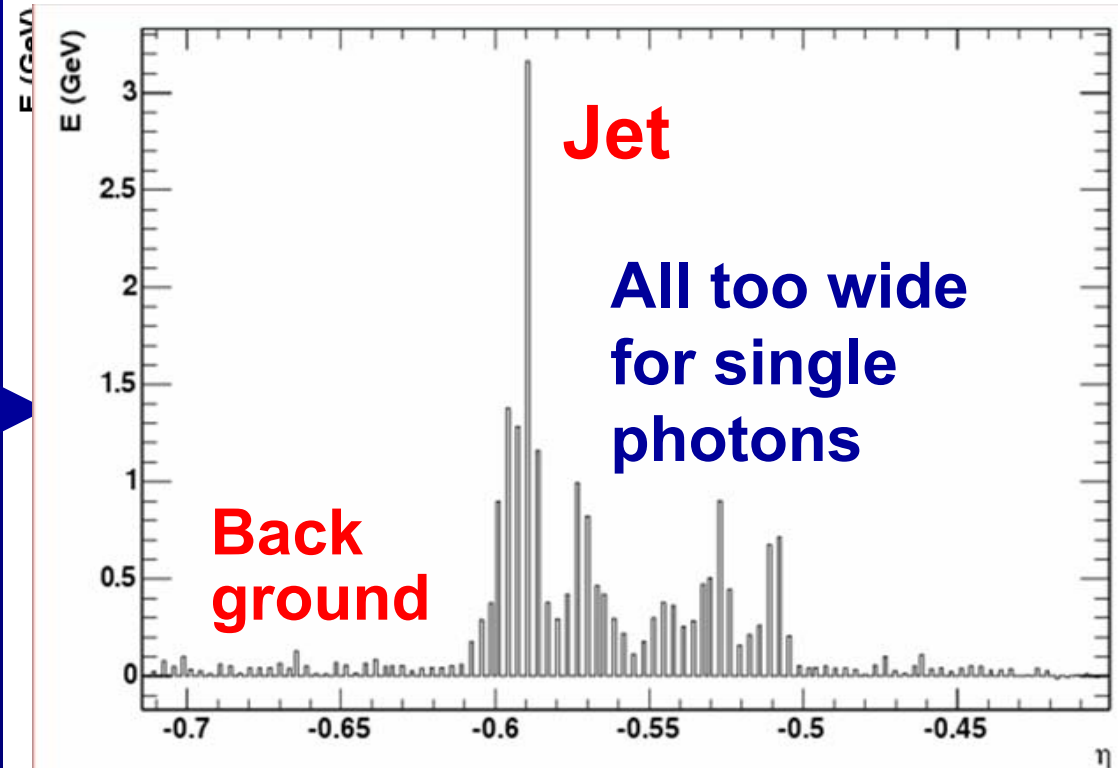
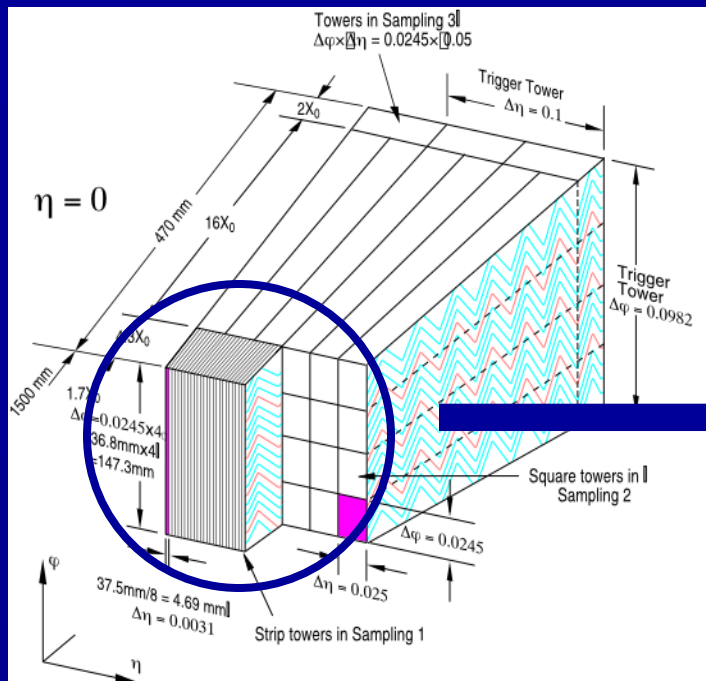

- Segmentation of first EM sampling layer so fine that heavy ion background is \sim negligible

$$-\langle N_{\text{chg}} + N_{\gamma} \rangle < 1, \langle E_T \rangle \sim 30 \text{ MeV}$$

- Fine $\Delta\eta \Rightarrow$ rejection of neutral hadron decays
- Clean 1st sampling \Rightarrow prompt γ isolation

ATLAS Heavy Ion: Primary Goals

- Measure $dn_{chg}/d\eta$, $dE_T/d\eta$ (total+EM)
 - Characterize gross properties of initial state.
 - Test saturation predictions
- Measure charged, inclusive γ , π^0 elliptic flow
 - Probe early collective motion of (s/t/w)QGP
- Measure jets, jet fragmentation, γ -Jet, di-jet, ...
 - Precision tomography of QGP & its properties
 - Medium response to passage of quenched jet
- Measure Upsilon production via $\mu^+\mu^-$
 - Probe Debye screening in medium
- Study low x hard processes in p-p, p-A
 - Study factorization violations, BFKL, saturation

Multiplicity from Si Hits

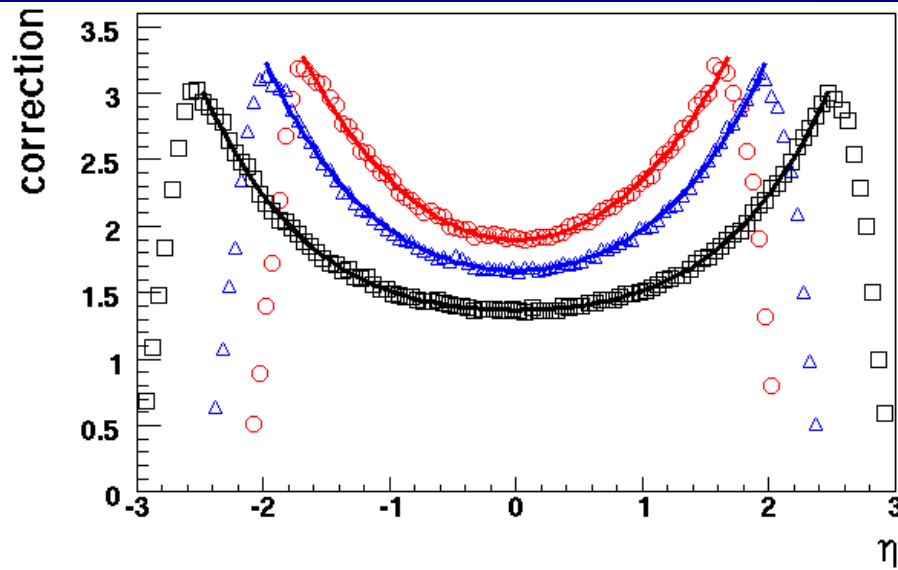

- Count clusters in each of 3 pixel layers
- **Correction** = $\frac{dN_{clus} / d\eta}{dN_{chg} / d\eta}$
- Apply to simulated events (single)

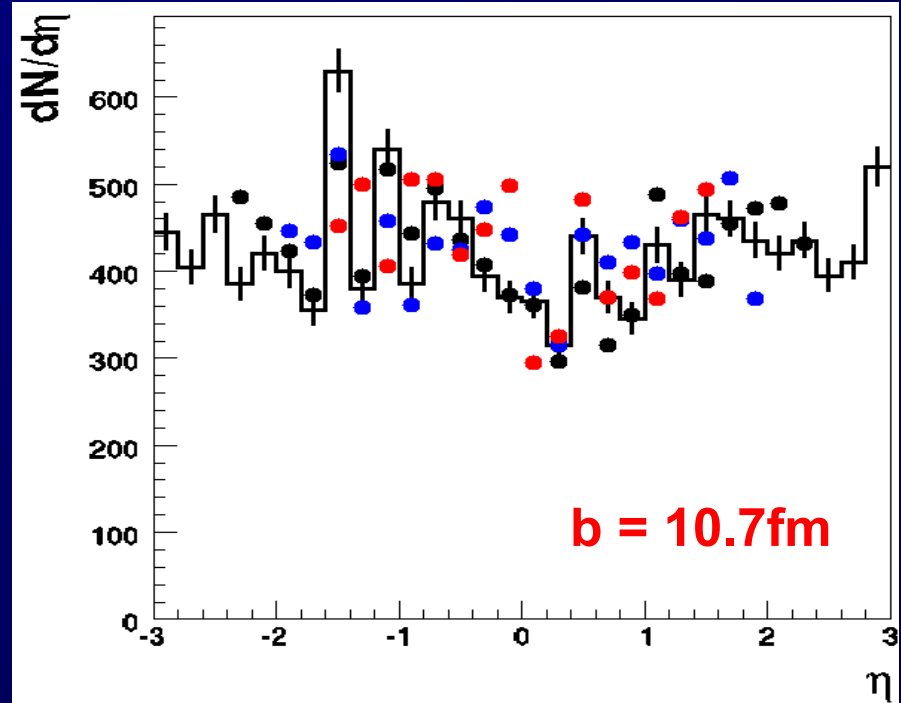
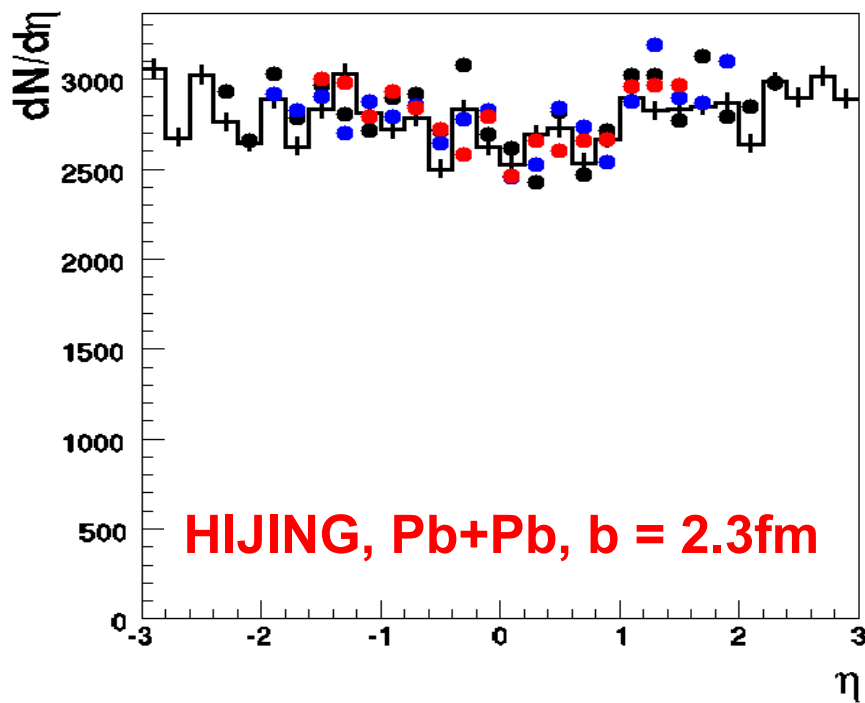

Charged Multiplicity from Tracklets

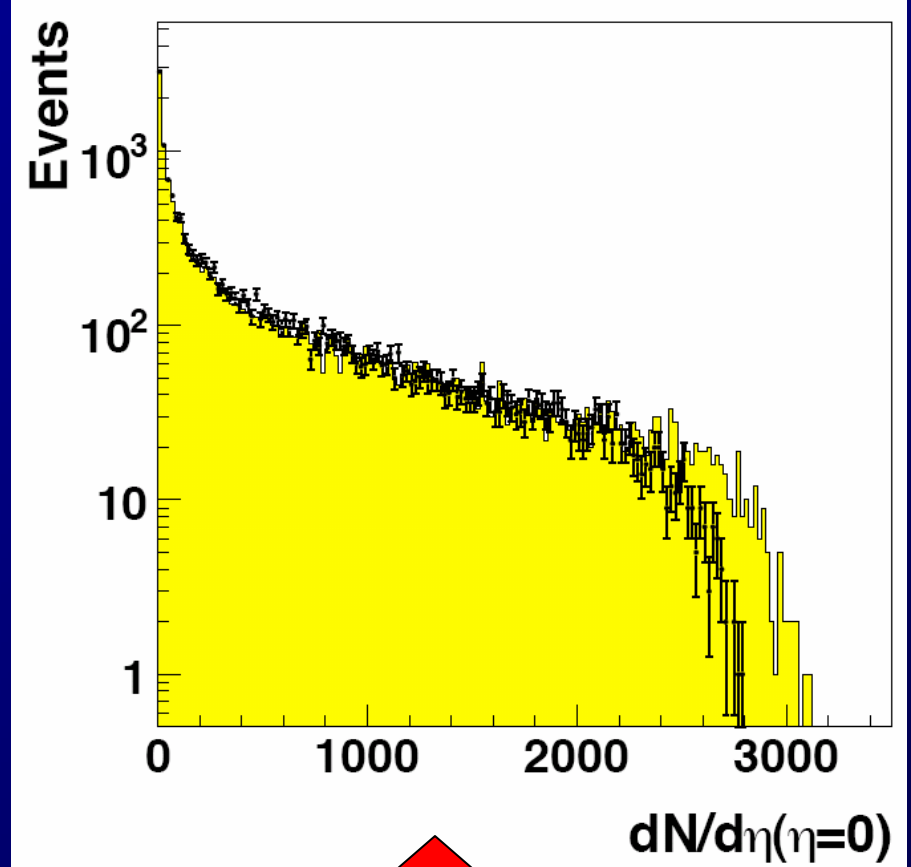
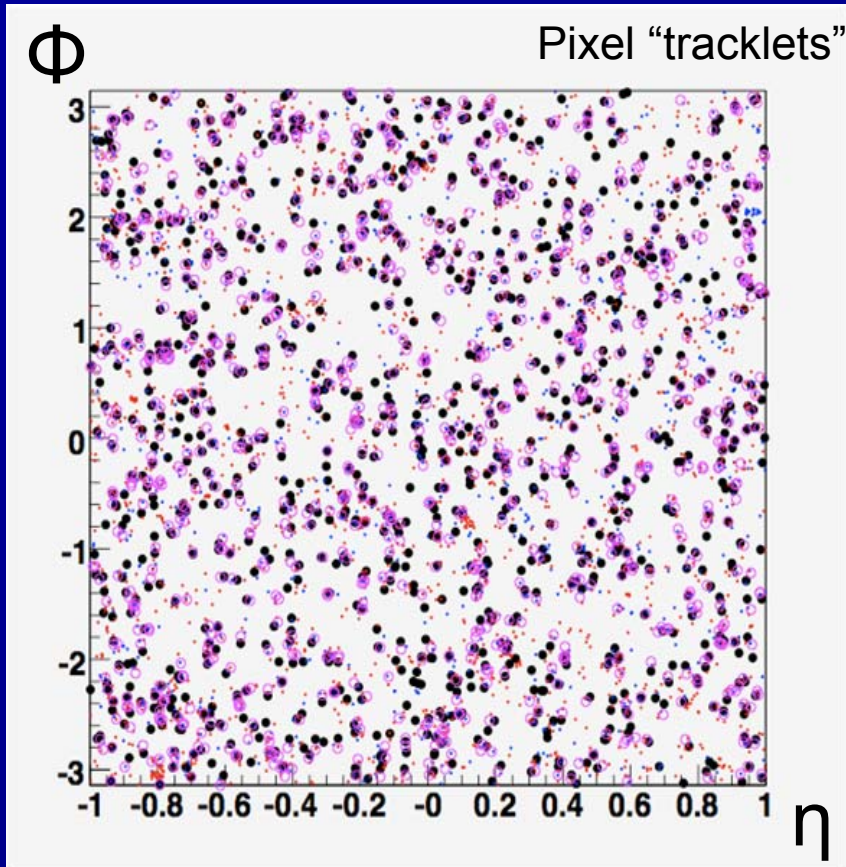

1. Truth tracks (black)
2. "B-Layer" Hits
3. Layer 1 Hits
4. Matched Tracklets

Histogram (yellow) – Hijing

Points (black) – Raw tracklets
(no corrections)

Charged Multiplicity from Tracklets

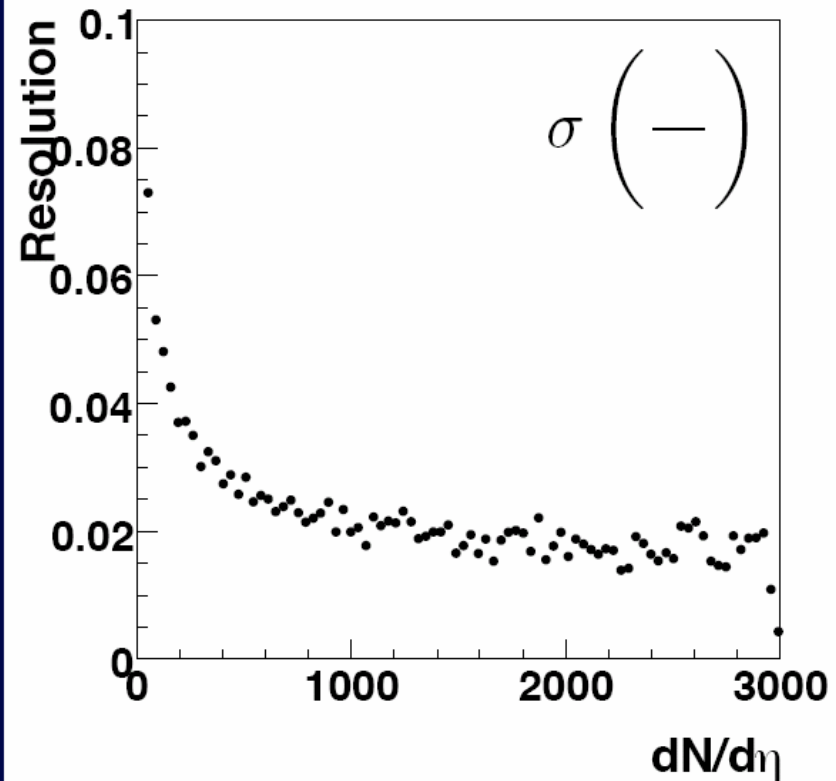
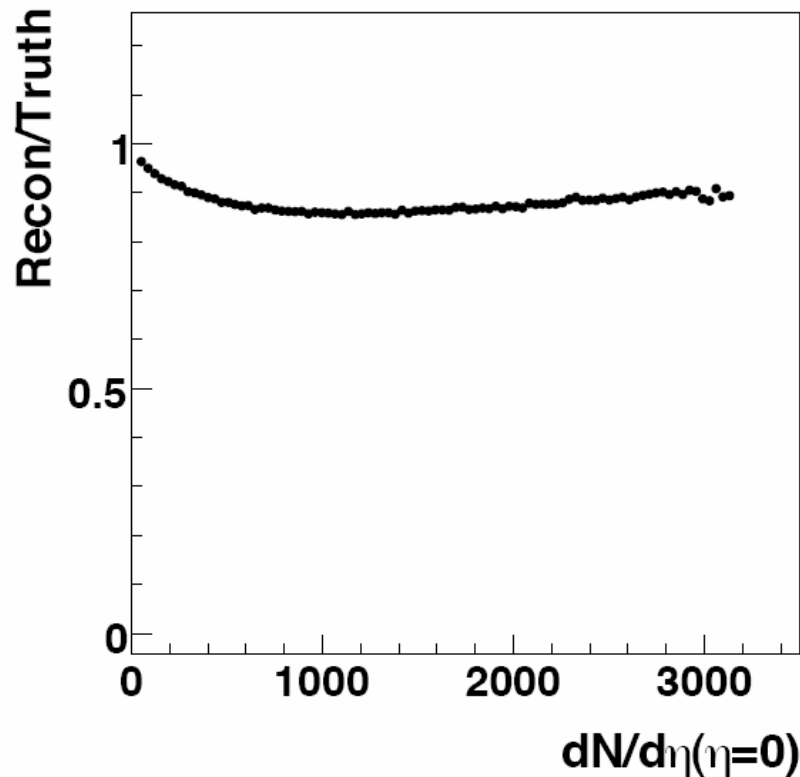

- **Tracklets provide a good estimate of multiplicity**
 - $< 20\%$ correction
- **$dn/d\eta$ resolution $\sim 2\%$**
 - except for most peripheral events

E_T Measurement

RHIC: $\langle E_T \rangle / \text{particle} \sim \text{constant}$



Reproduced by HIJING

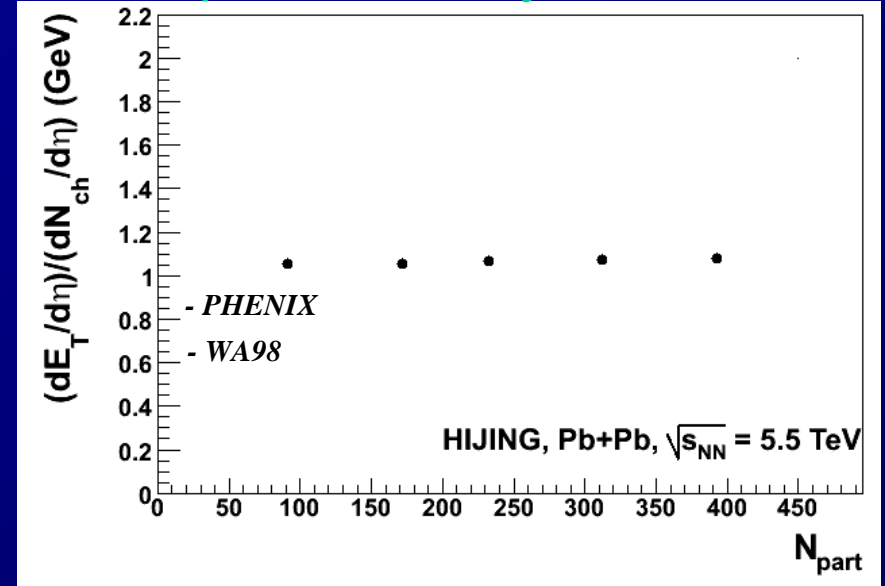
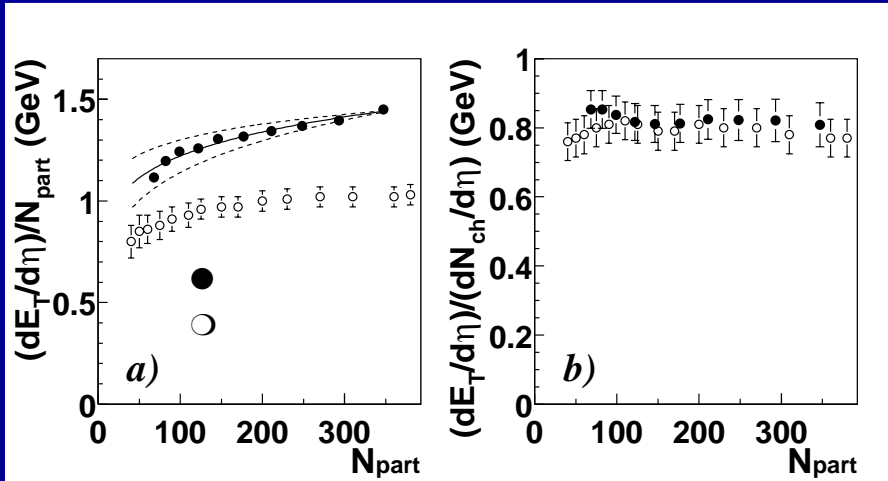

E_T in ATLAS (full simulation)



HIJING $b=2.3$, corrected

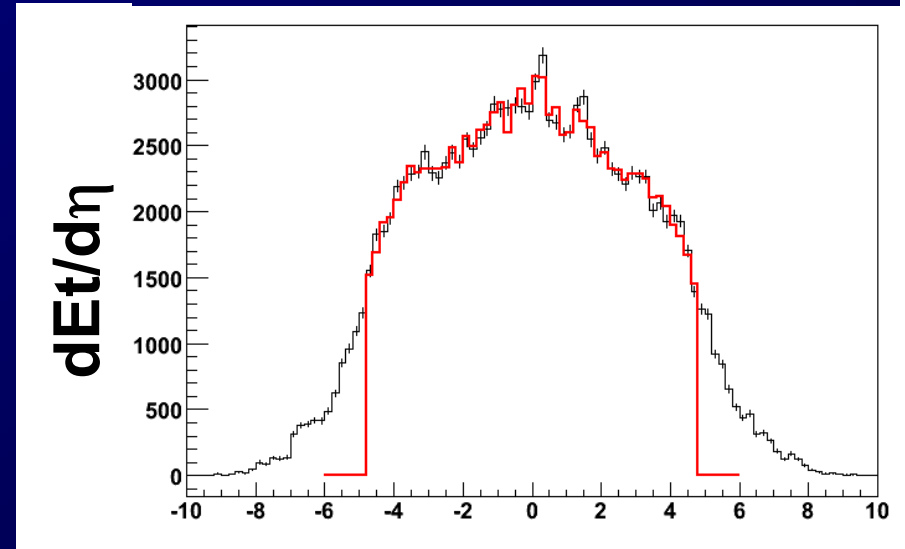
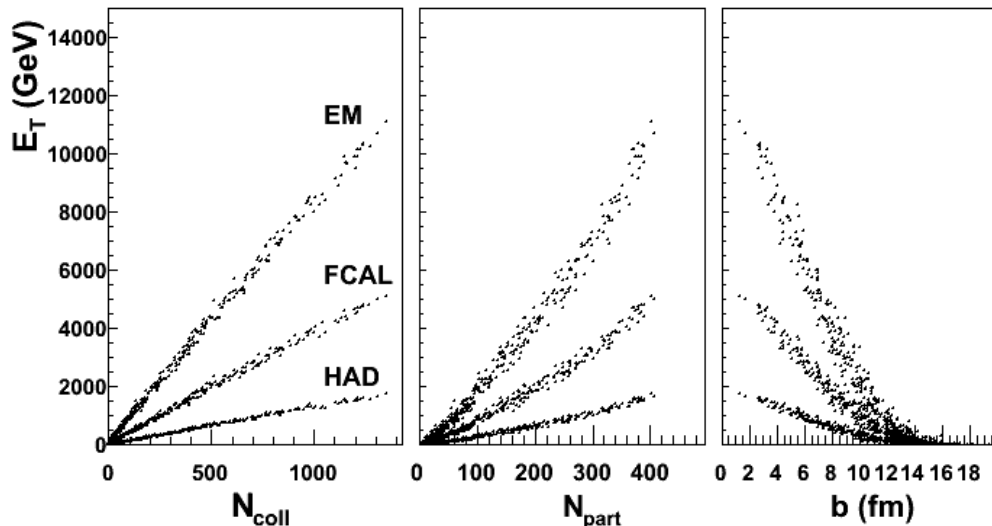

Centrality Determination

Reaction Plane w/ Calorimetry

- Flow imposed on HIJING events via ϕ shift
 - *a la* Poskanzer and Voloshin, PRC 58 (1998).
 - Parameterization of RHIC $v_2(N_{\text{part}}, p_T)$
- Characterize Φ_{RP} via v_2 correction factor

$$= \sqrt{2 \langle \cos(\Phi_2 - \Phi_1) \rangle}$$

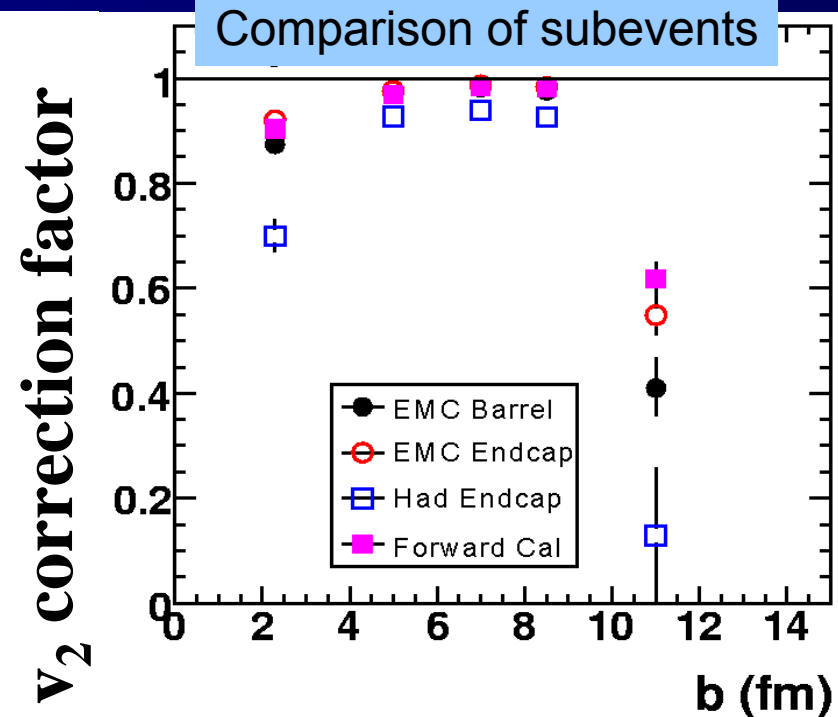
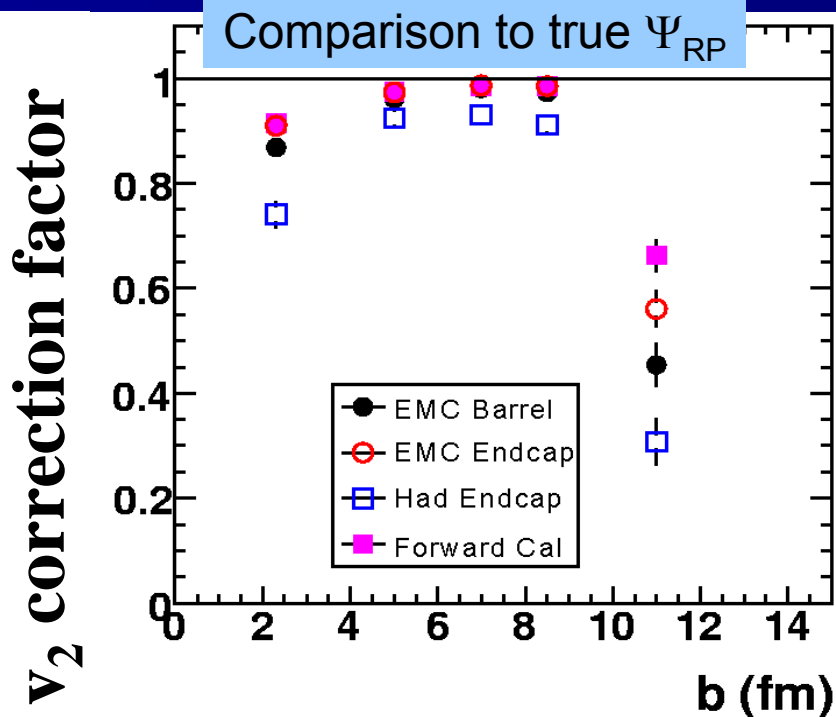

Reaction Plane w/ Tracks

- As above, HIJING + φ shift w/ parameterized RHIC $v_2(N_{\text{part}}, p_T)$
- Use reconstructed tracks $p_T > 0.5 \text{ GeV}/c$, $|\eta| < 2.5$
- Reaction plane resolution via $\sqrt{2\langle \cos(\Phi_{\text{rec}} - \Phi_{\text{true}}) \rangle}$

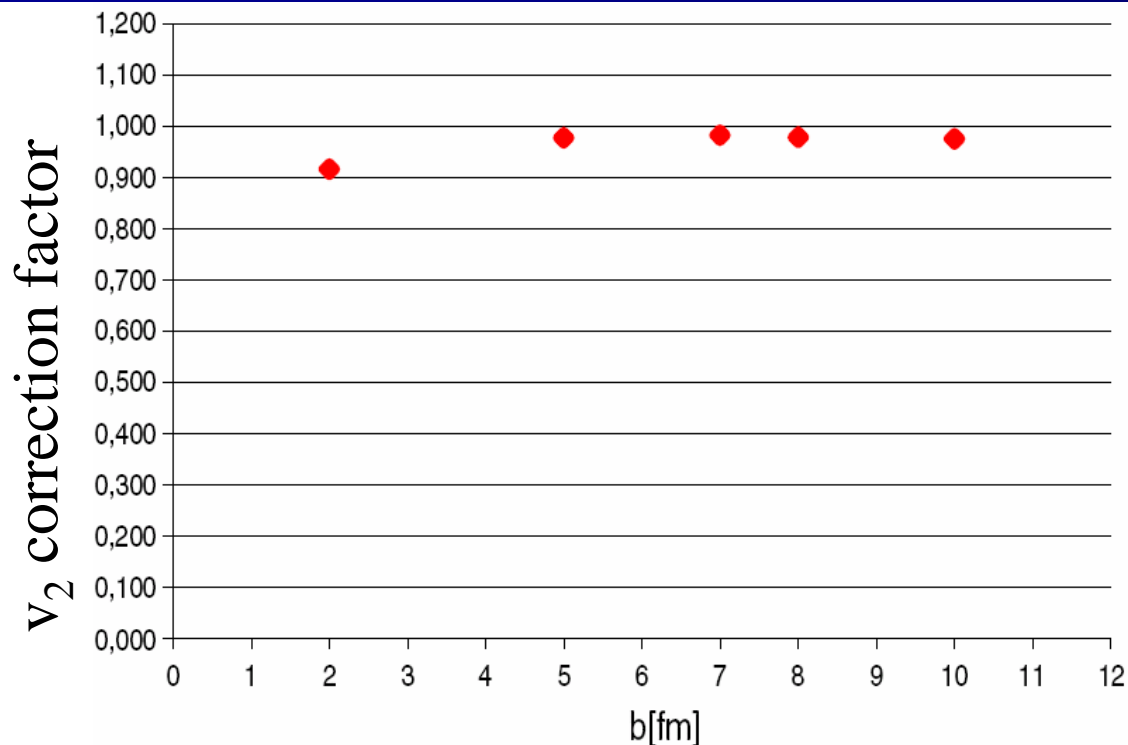

Impact parameter [fm]	v2_truth	v2_corr
2.3	0.056	0.056
5.0	0.124	0.125
7.0	0.153	0.154
8.5	0.168	0.168
10.7	0.202	0.202

Jets in A+A

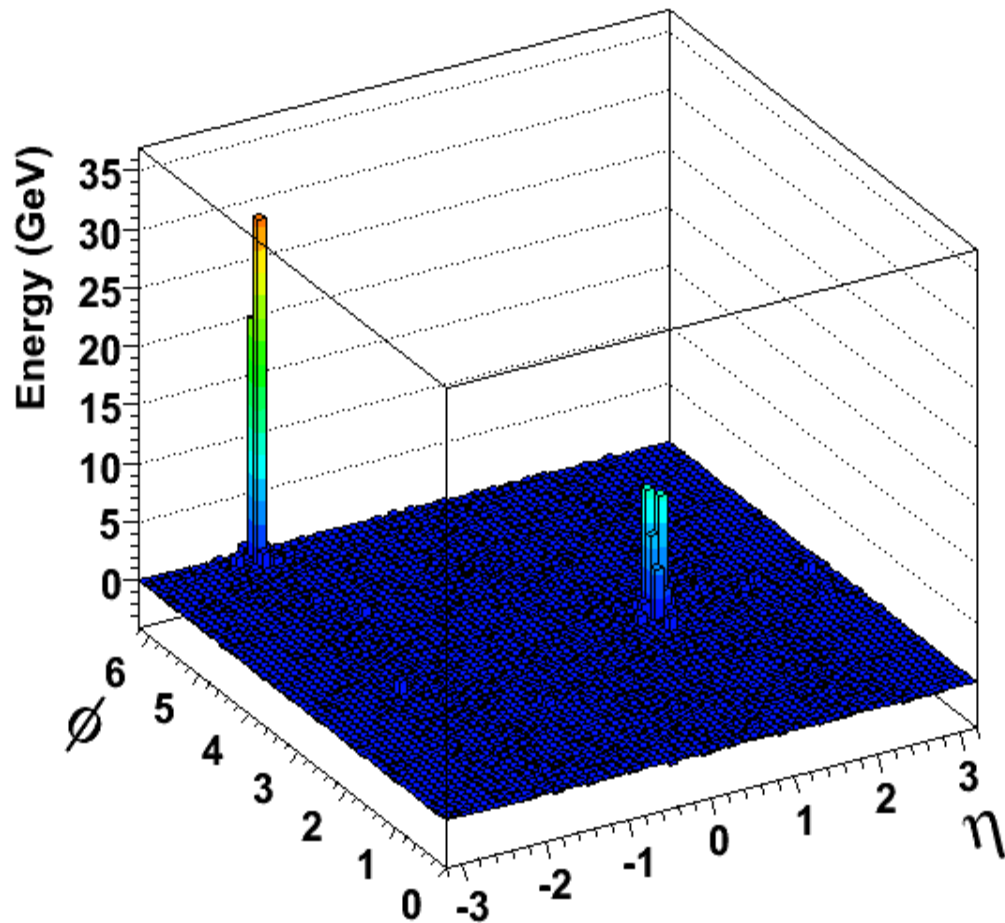

**Jets from
PYTHIA
in 0.1x0.1
(logical) towers**

Jets in A+A

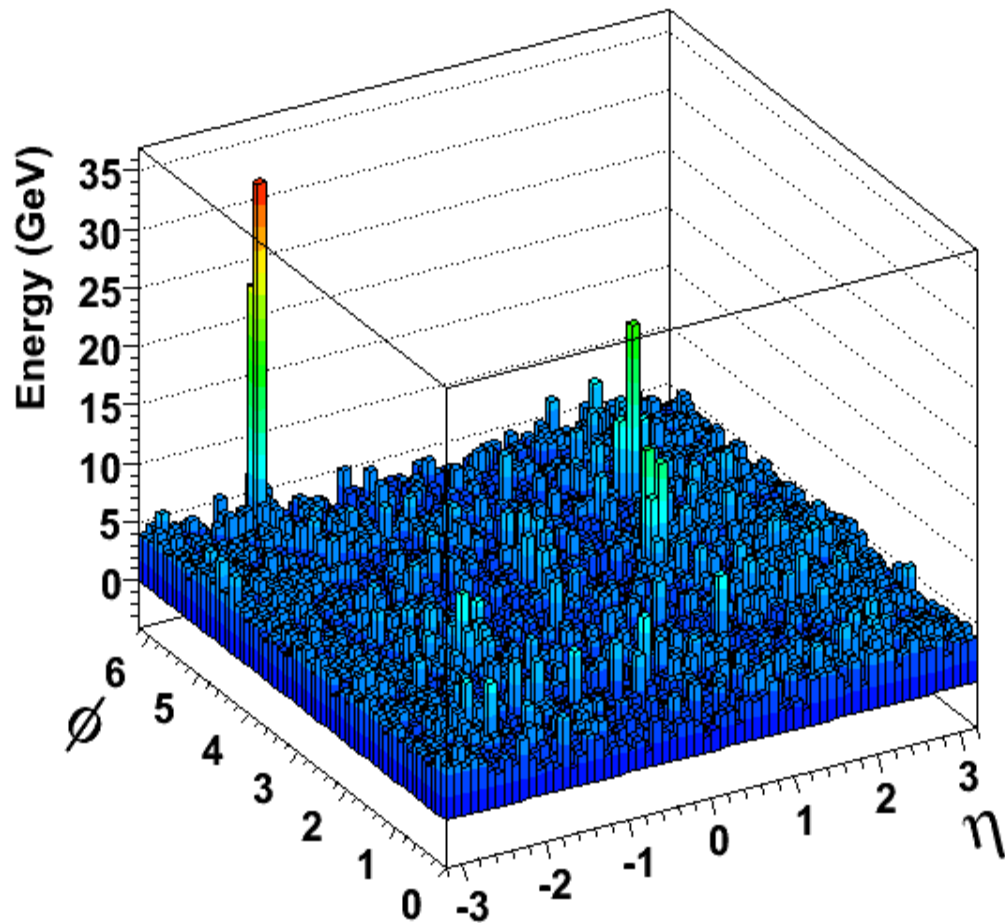

**Jets from
PYTHIA
in 0.1×0.1
(logical) towers**

**merged with
 $b = 2$ fm Pb+Pb
event (HIJING)**

Jet Reconstruction: E_T Resolution

- Pythia di-jet events with $35 < E_T < 280$
 - Merged (post GEANT) into $b = 2$ fm HIJING events.
- Reconstructed w/ **$R=0.4$ seeded** cone algorithm
 - Seed: $E_T > 5$ GeV in $\Delta\eta\Delta\phi = 0.1 \times 0.1$ tower
- Compared to **$R=0.4$ seeded** cone algorithm on **Pythia final-state particles.**

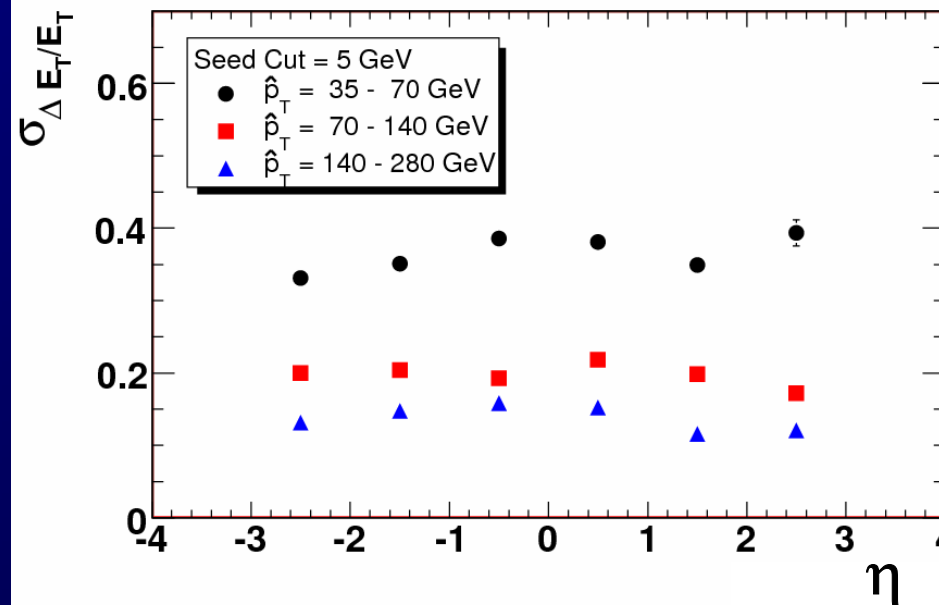
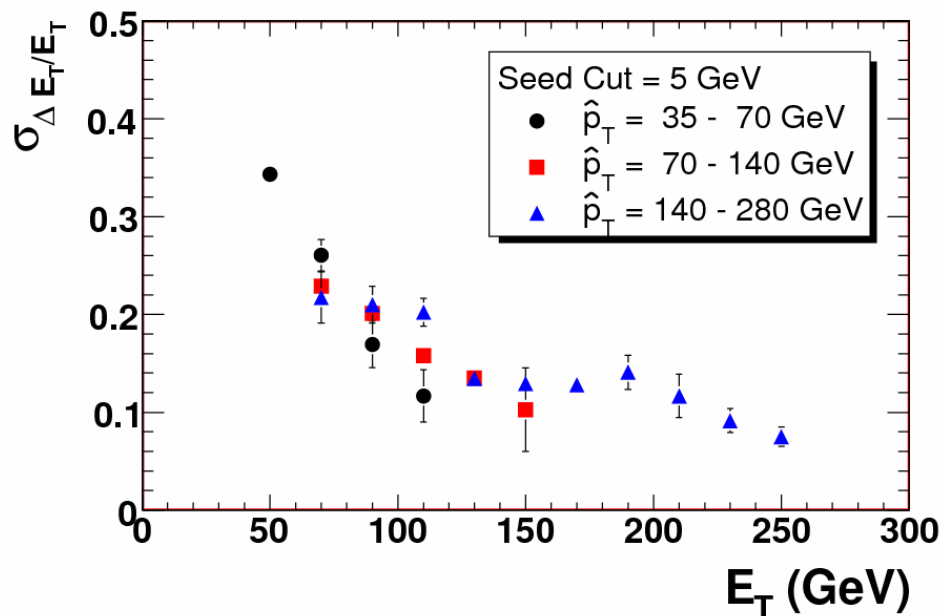

Jet Reconstruction: b dependence

- **Pythia + HIJING performance vs b**
 - $R = 0.4$ seeded cone jet algorithm
 - Here, Pythia jets in $70 < E_T < 90$ GeV
 - Position resolution
 - Energy resolution
- **Smooth evolution with centrality**
- **By $b = 10$ ($N_{\text{part}} = 100$) reach p-p performance.**

Pythia Jets: $70 < E_T < 90$ GeV

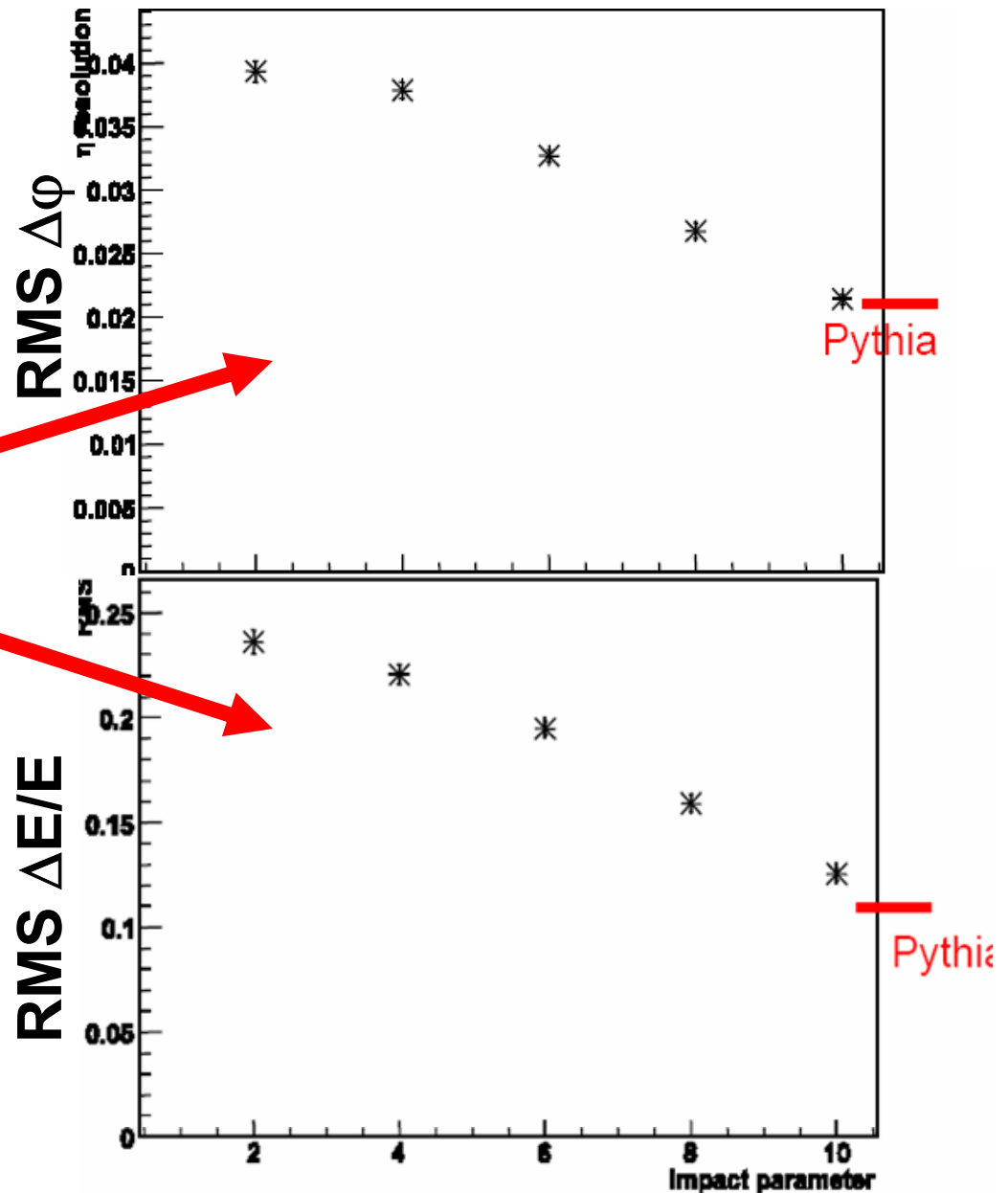

Jet Fragmentation Observables

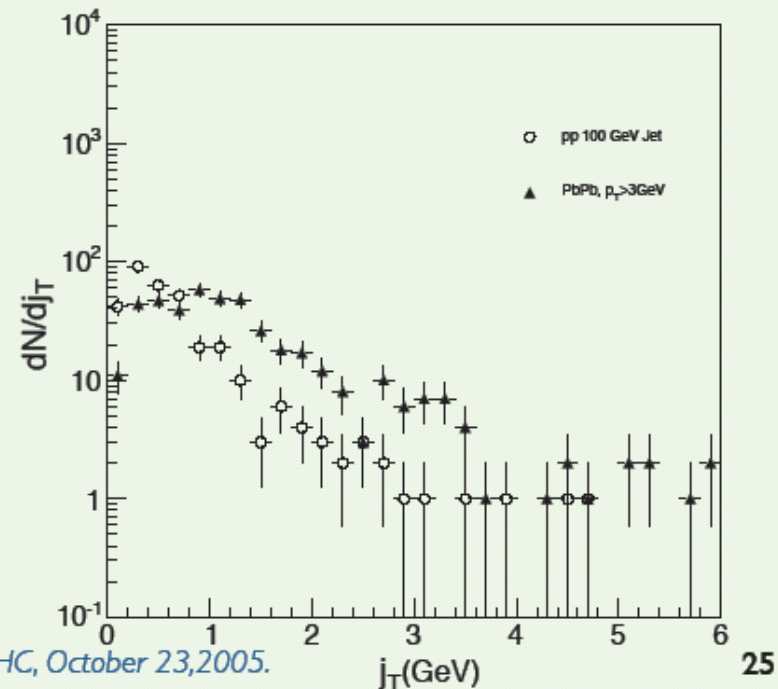
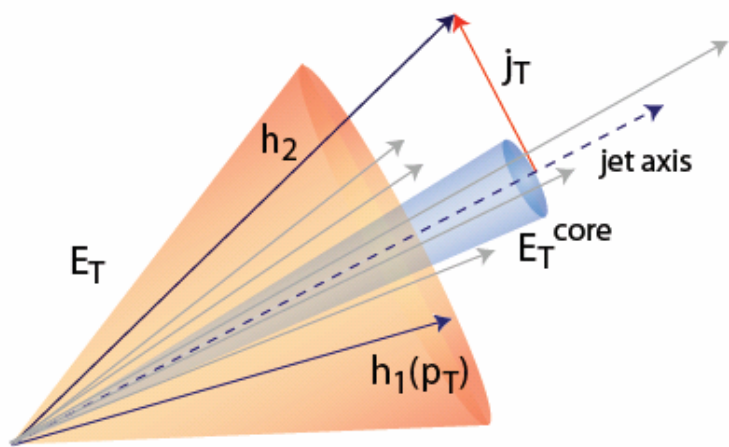
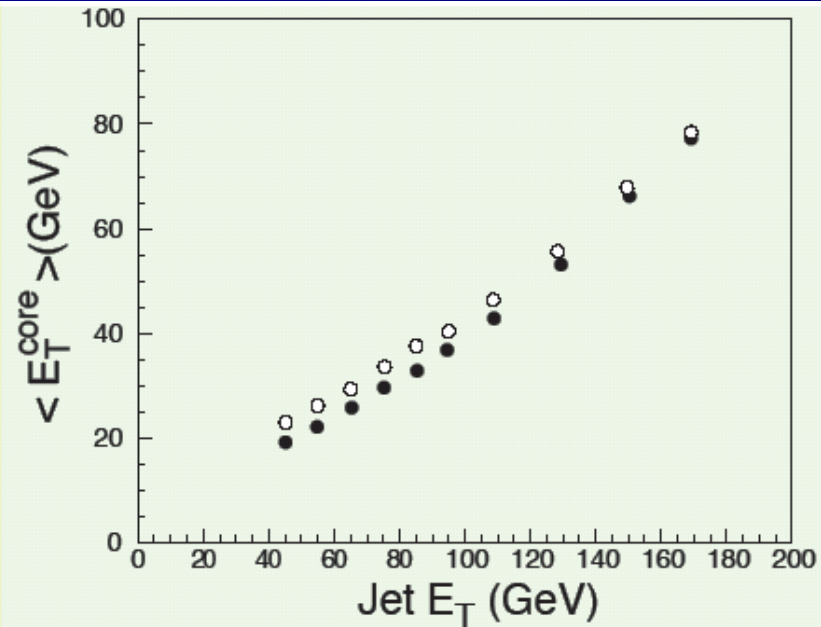
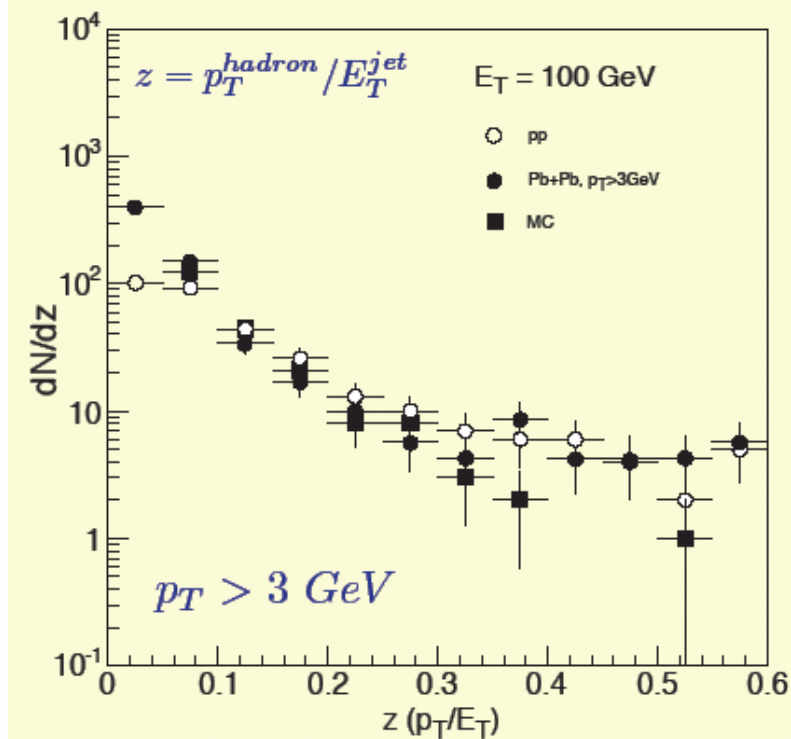

PANIC 2005, Heavy Ions at LHC, October 23, 2005.



k_T Jet Reconstruction

- k_T jet algorithm has several advantages
 - Unseeded (better QCD predictability)
 - Explicitly accounts for angular ordered parton showers
 - Adapts to distorted (non-conical) jet shapes
- With algorithmic optimization by Cacciari, becomes feasible in Pb+Pb (faster than cone)

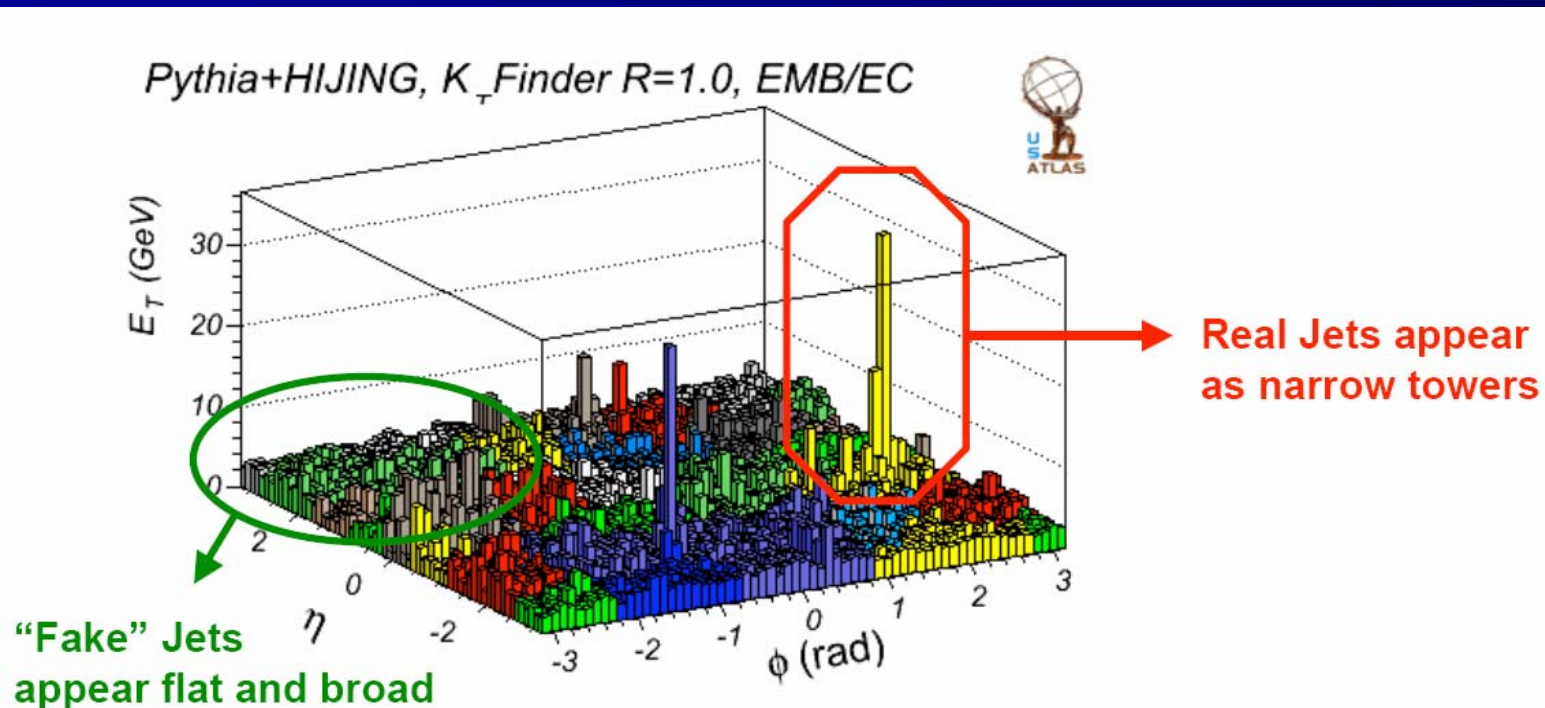

k_T Jet Reconstruction (2)

- **Cacciari:**

- Use K_T algorithm w/o subtraction.
- Use fake jets to estimate background, subtract.

- **ATLAS:**

- Use jet $E_T^{\max} / \langle E_T \rangle$ using $\Delta\eta \times \Delta\phi = 0.1 \times 0.1$ towers to distinguish real & fake jets.

Central Pb+Pb event + $q_T = 140$ GeV Pythia, EM energy only

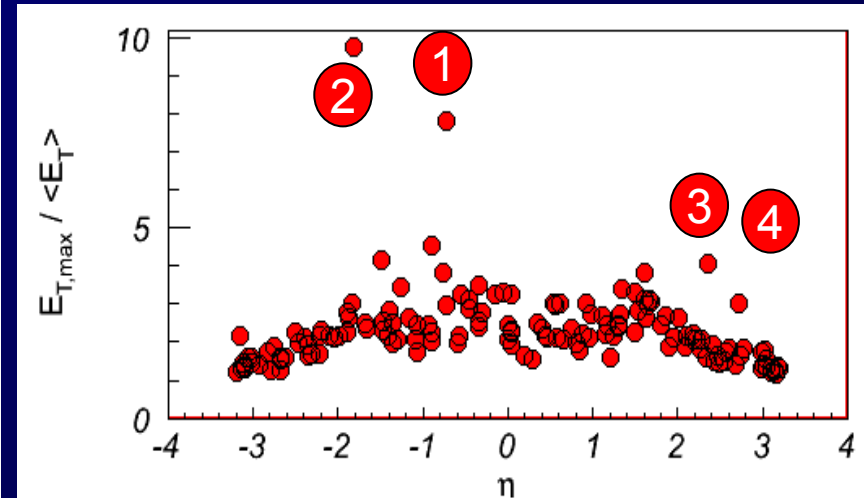
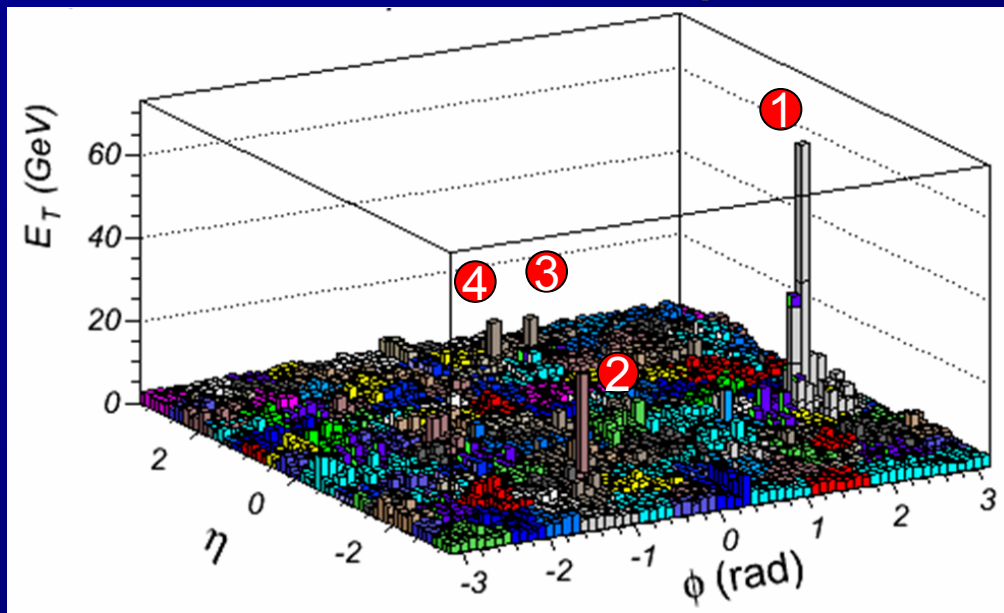

k_T Jet Reconstruction (3)

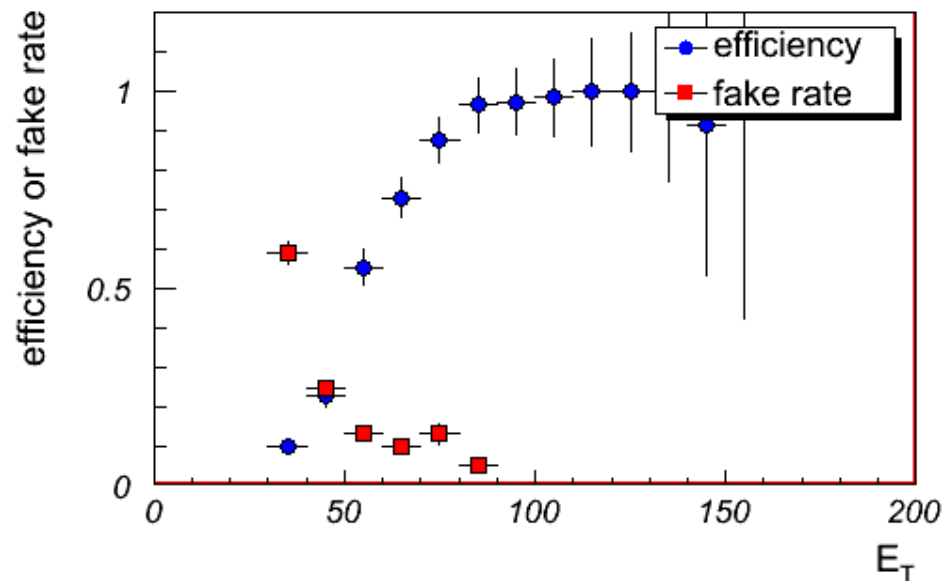
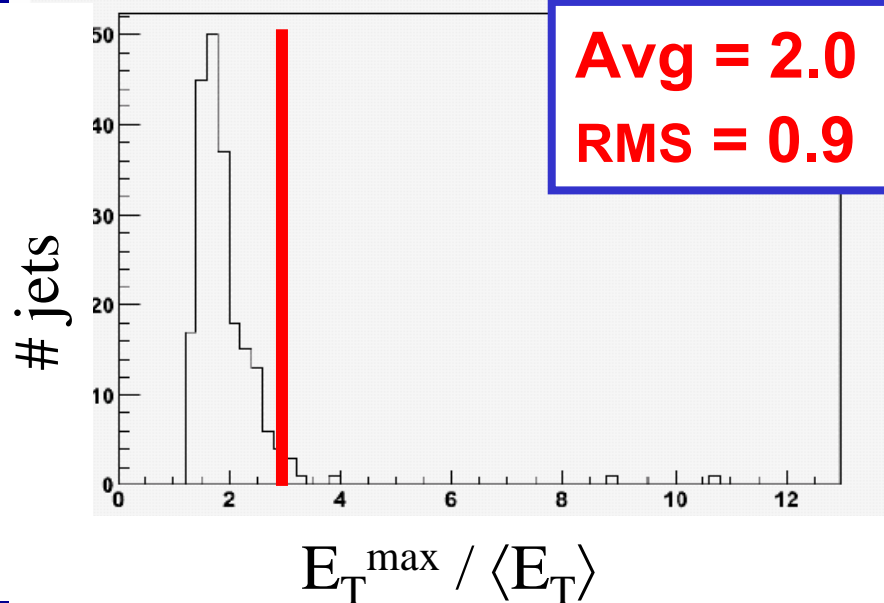

Very preliminary

- K_T algorithm with "R=0.4"
 - $E_T^{\max} / \langle ET \rangle$ cut at avg. + 1σ
- 1st study of performance of fast k_T algorithm in Pb+Pb
- **But a crucial proof-of-principle showing the method works**

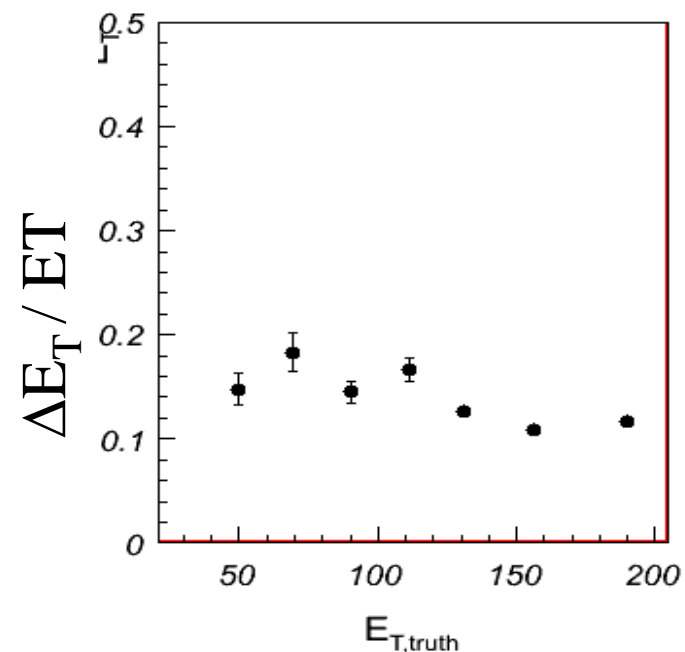

Y Detection: Resolution & Efficiency

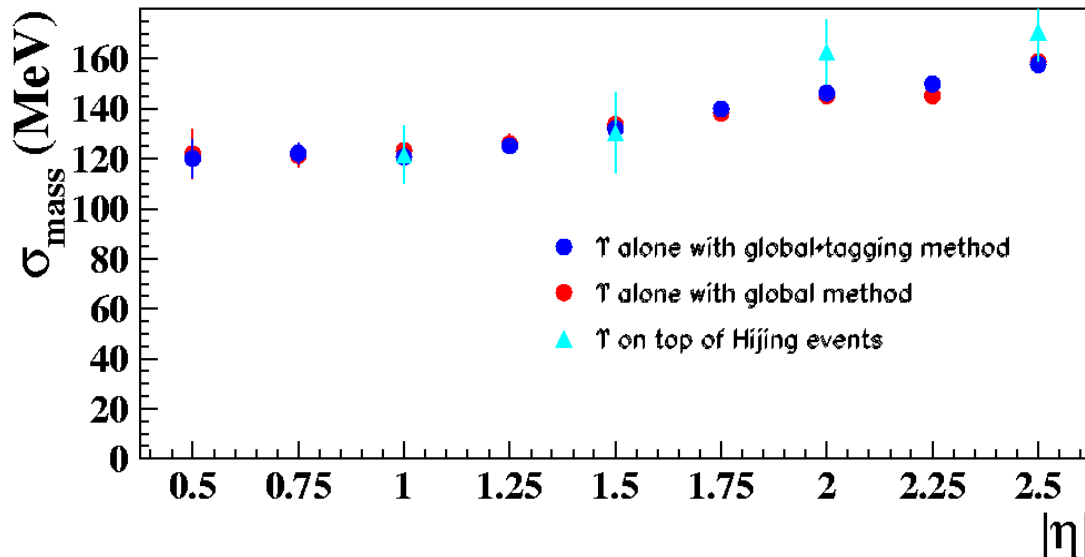

- Good mass resolution
- Large acceptance
- Loss of efficiency near $\eta \sim 0$ due to gaps, supports

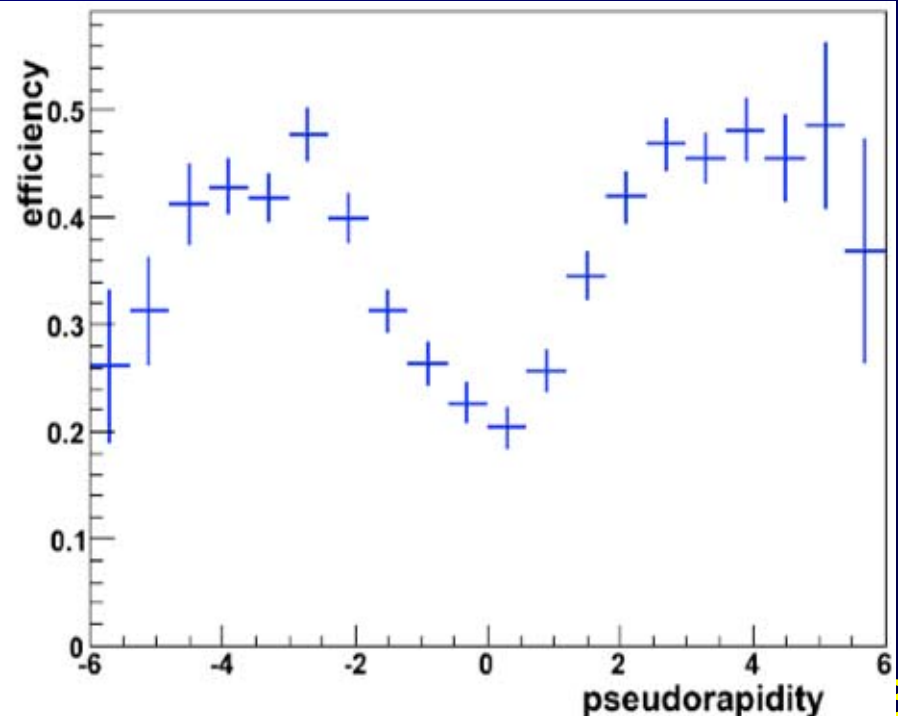
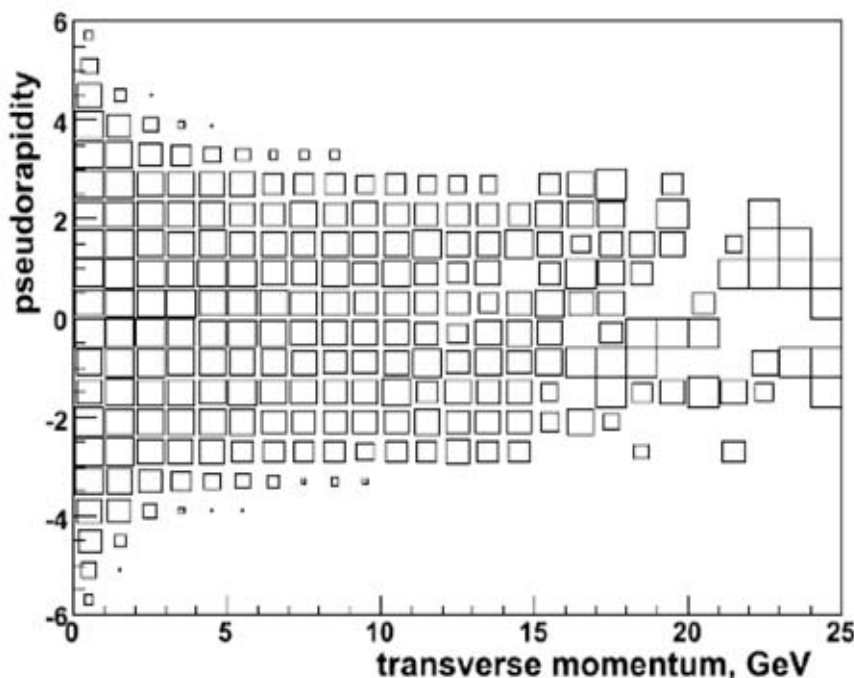

Summary

ATLAS: Gamma-Jet

Pythia γ + jet (75 GeV) superimposed on $b=4$ fm HIJING Pb+Pb event, full GEANT

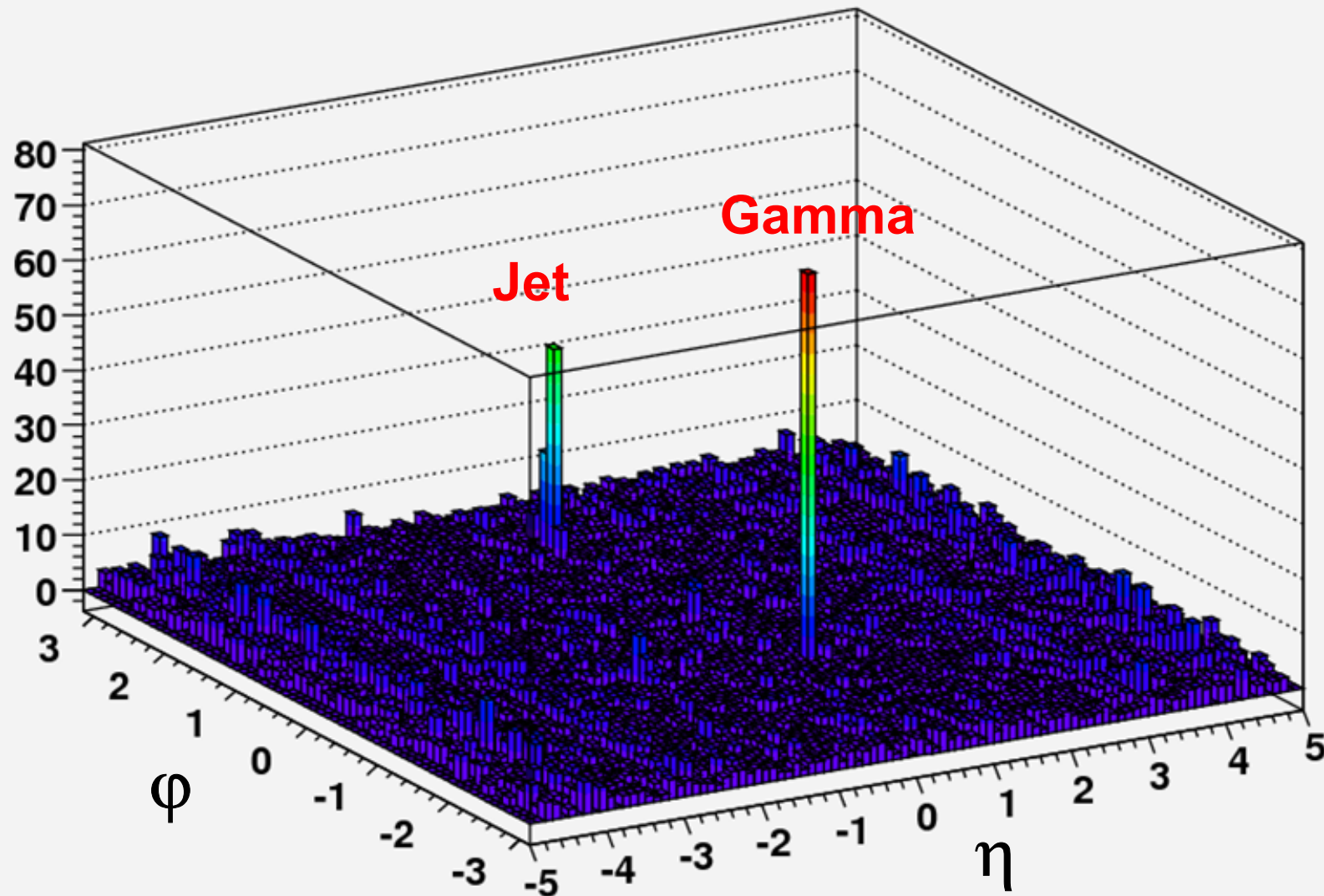

ATLAS: Gamma-Jet

Pythia γ + jet (75 GeV) superimposed on
 $b=4$ fm HIJING Pb+Pb event, full GEANT

Background subtracted

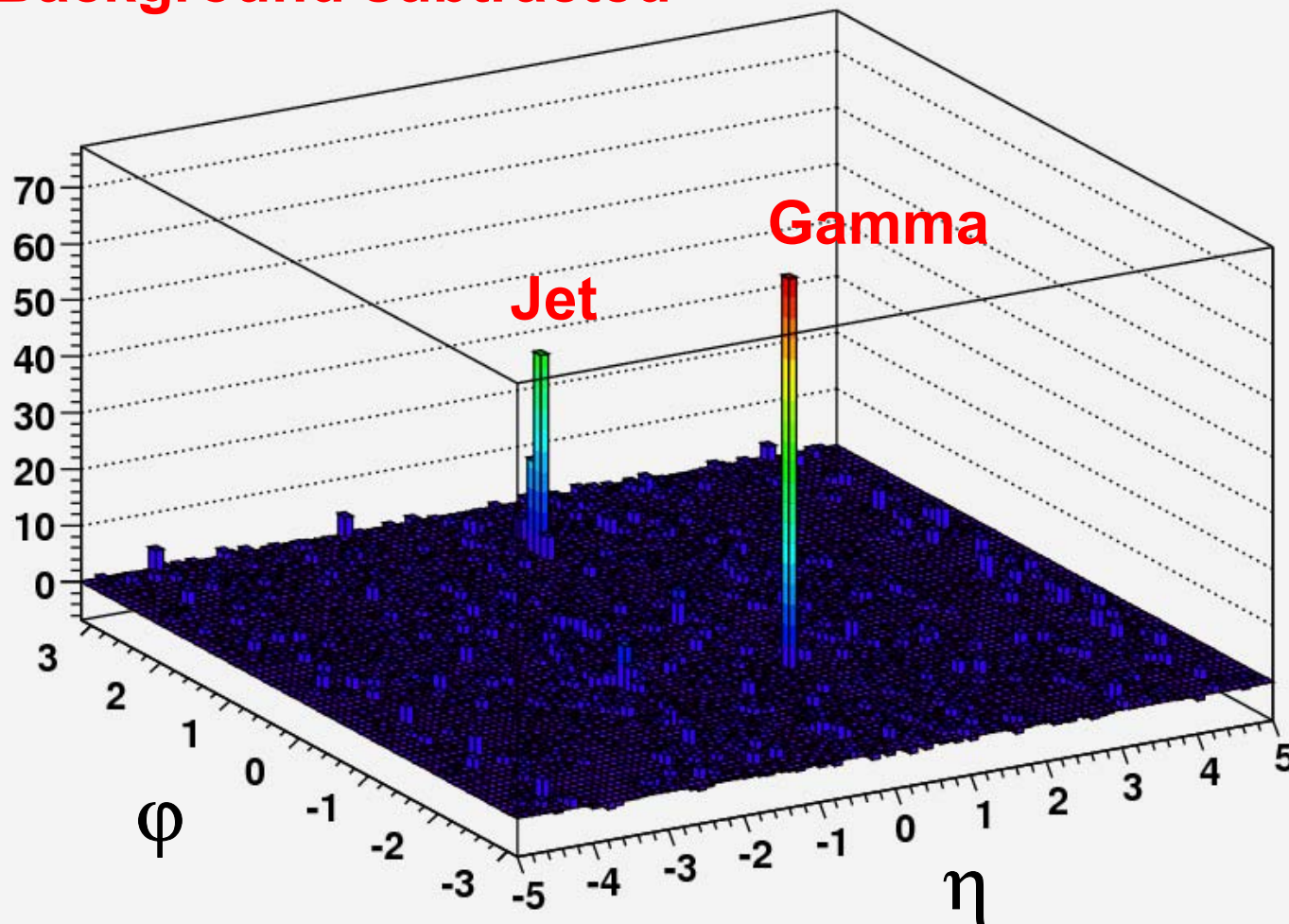

ATLAS: Gamma-Jet, EM 1st Layer

Zoom in on
barrel EM
calorimeter 1st
sampling layer

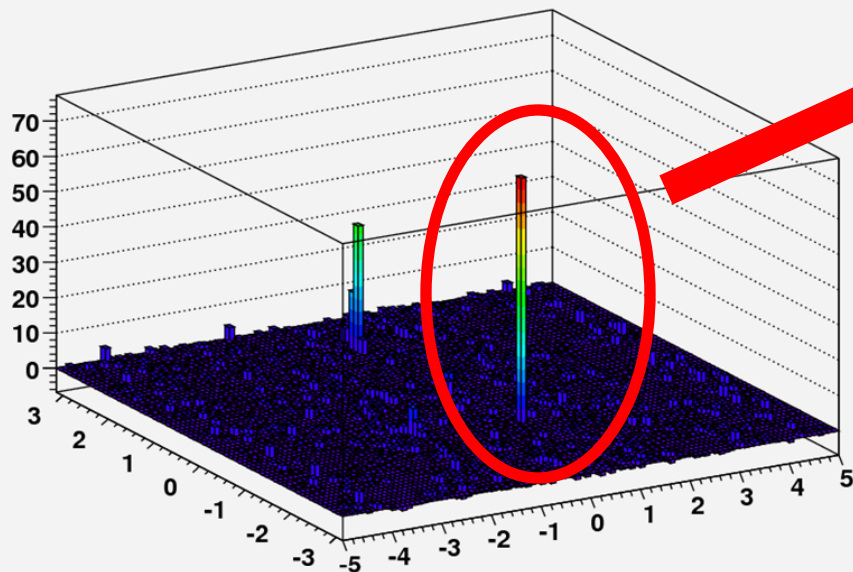
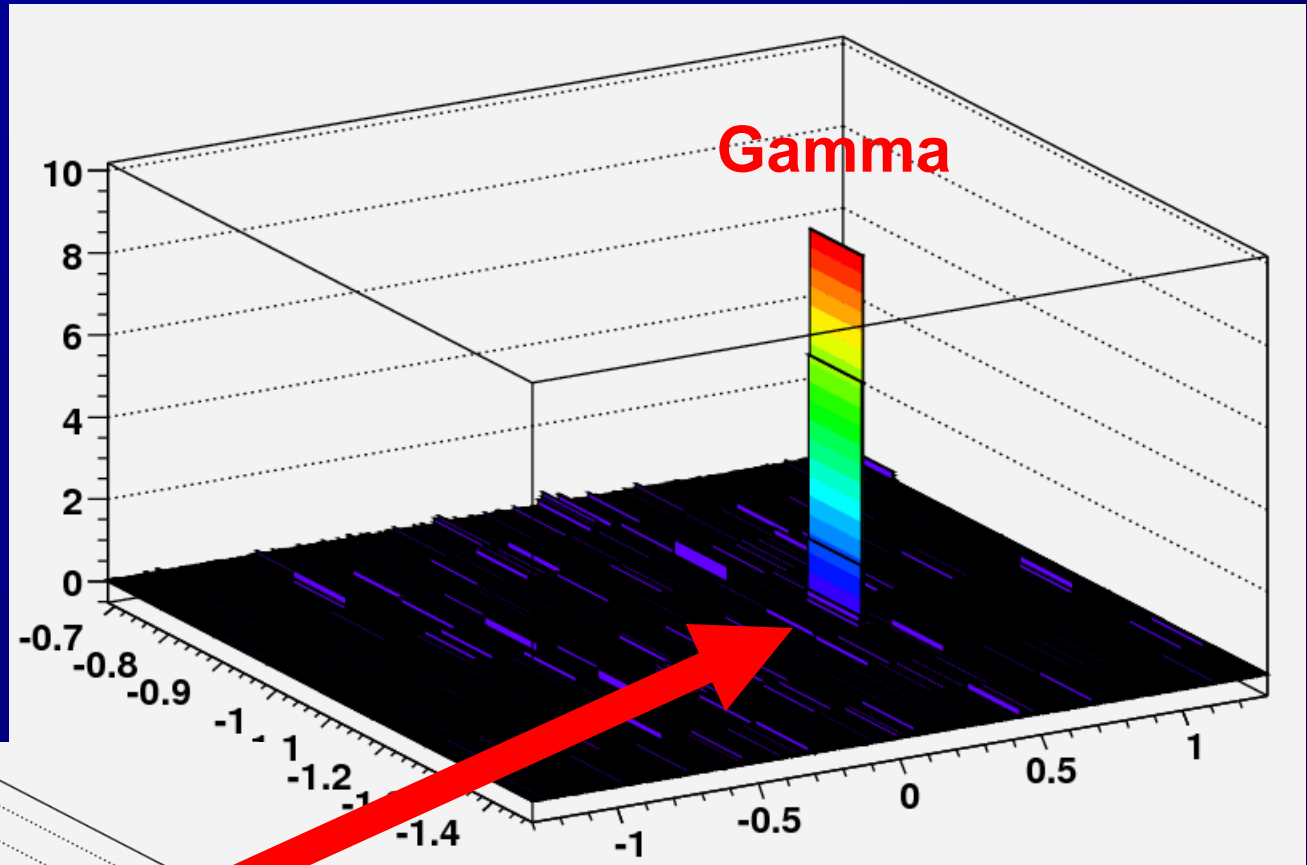

1st layer unaffected by
Pb+Pb background

⇒ isolation w/ 1st layer
~ unaffected by Pb+Pb

Low-x Physics w/ ZDC

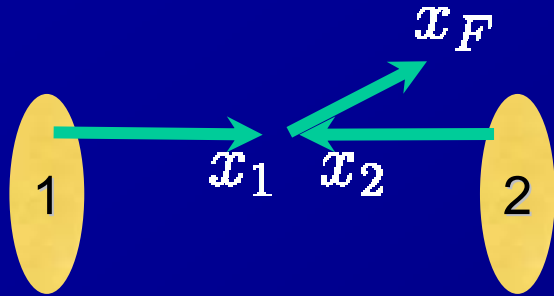

$$x_F = x_1 - x_2$$

$$x_1 x_2 = \frac{m_T^2}{s}$$

$$x_1 \sim \frac{m_T}{\sqrt{s}} e^y \quad x_2 \sim \frac{m_T}{\sqrt{s}} e^{-y}$$

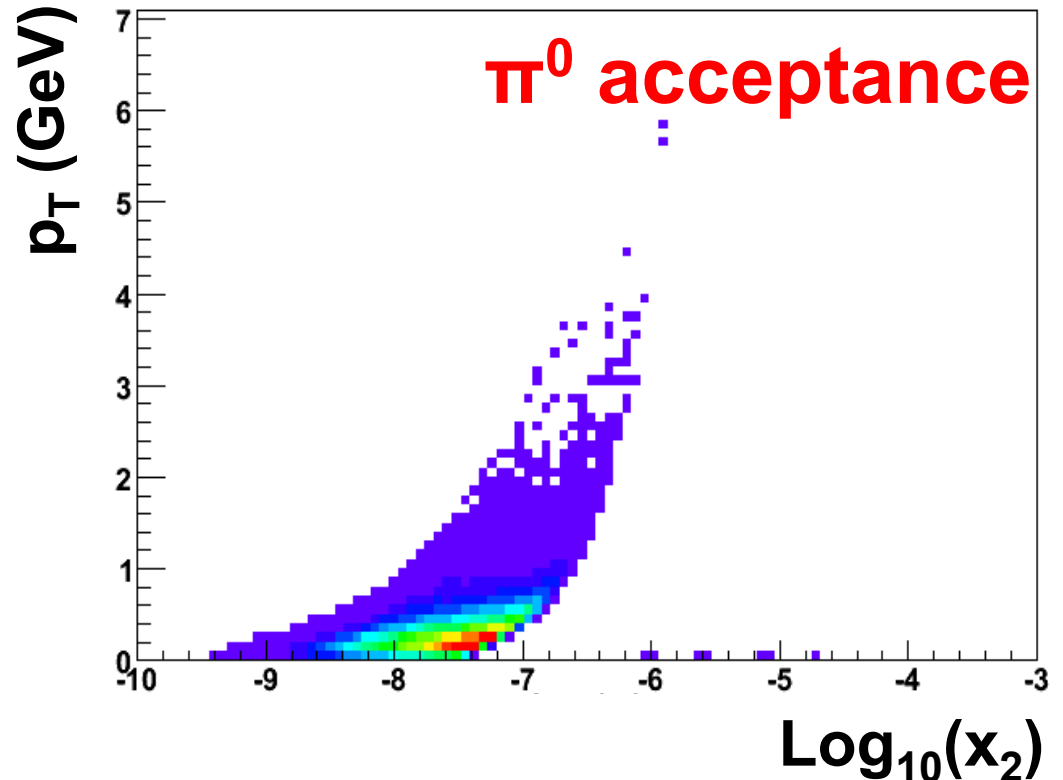

- ZDC w/ precision EM module measures semi-hard π^0 , η , Λ , ... production at $x \sim 10^{-6}$ in p-p and p-A collisions
- Correlate with mid-rapidity jets

ZDC π^0 , η , Λ , ... Reconstruction

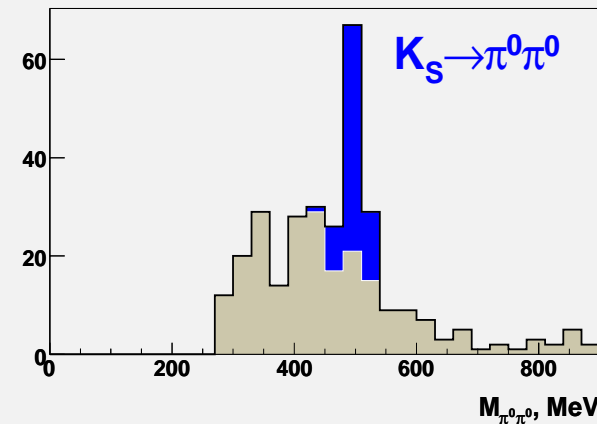
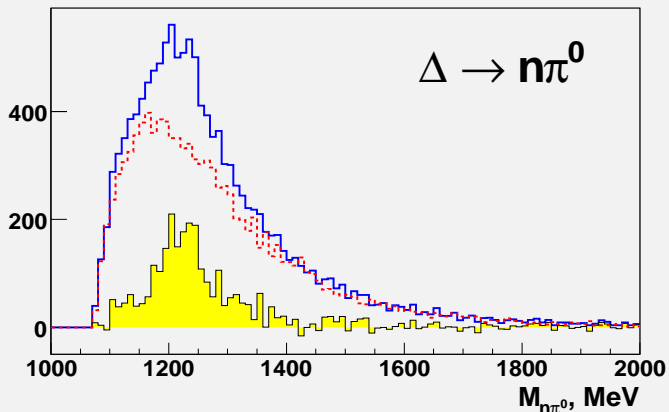
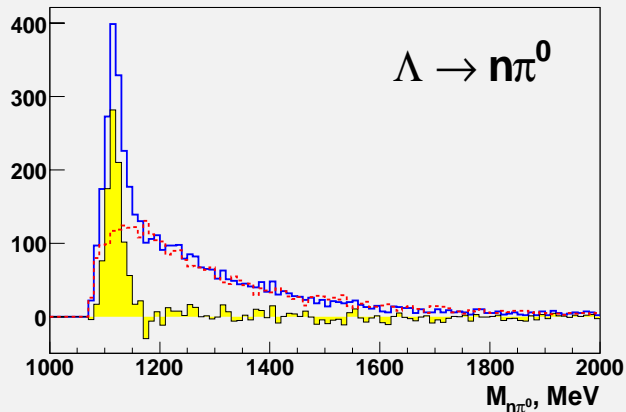
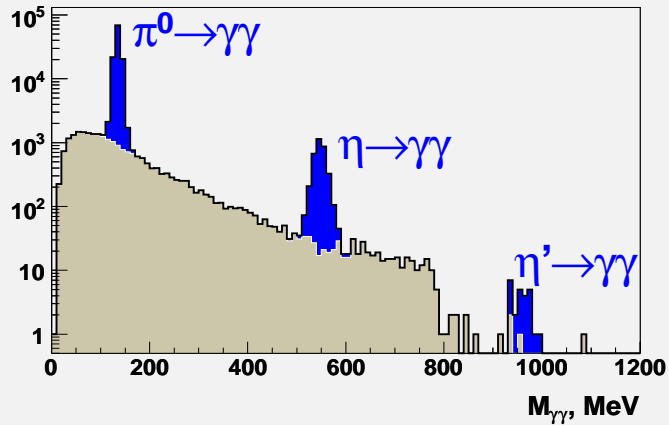

Obtained with cut on total energy, $E > 200$ GeV

Very little background from non-vertex sources

- In p-p and p-A, position resolution of ZDC EM module allows clean measurement of π^0 , η , Λ , ...
– Huge benefit to low-x physics program