

System design of 60 K Stirling-type coaxial pulse tube coolers for HTS RF filters

Y.L. Ju ^{*}, K. Yuan, Y.K. Hou, W. Jing, J.T. Liang, Y. Zhou

*Cryogenic Laboratory, Technical Institute of Physics and Chemistry, Chinese Academy of Sciences,
P.O. Box 2711, Beijing 100080, China*

Abstract

We report on system design of 60 K Stirling-type coaxial pulse tube coolers for the purpose of developing a fully integrated, cryogen-free operation of HTS RF filter subsystem for wireless telecommunications. Two different cold finger geometries of single-stage and two-stage pulse tube coolers are analyzed and designed. The design objective of the coolers is for 3.5 W of cooling capacity at 65 K with a specific power of 30 W/W. The construction of the cooled HTS filter subsystem integrated with the coolers is also described.

© 2002 Elsevier Science B.V. All rights reserved.

PACS: 07.20.M; 85.25.N

Keywords: Pulse tube coolers; Cooling; HTS RF filters

Cooling with easy, reliable, and compact cryocoolers is highly desirable for the operation of HTS electronic devices [1,2]. In the past decade the progress in pulse tube coolers (PTCs) has been impressive. Many new ideas, incorporated with refined thermo-mechanical design and fabrication, lead to significant improvements in thermal efficiency [3,4]. The PTCs have no moving parts at cold head, so that the mechanical vibration and magnetic noise can be reduced to negligible levels with higher reliability and longer lifetime than other coolers.

There is a long-term growth application of cryocoolers for HTS RF filter subsystems for

wireless telecommunications. In order to improve the voice transmission quality by reducing inter-channel EMI of cellular phone systems, the HTS RF filters integrated with an array of low noise amplifiers (LNAs) are usually used. The HTS filters are passive devices and must be cooled below their transition temperature (usually 65–80 K) in order to operate properly. The HTS filters are usually connected through a coaxial cable to the LNAs, which are active devices and induce a few hundred milliwatts of thermal load. In addition, the LNA array is connected to a feedthrough of the vacuum chamber by coaxial cable, which introduces also a few hundred milliwatts of heat. The thermal radiation from the vacuum wall to the cooled surface is the third contributor to the heat load. The signal-to-noise ratio of LNAs is improved significantly when cooled to a temperature of 90–110 K. Cooling is being performed either by

^{*} Corresponding author. Tel.: +86-10-6262-7302; fax: +86-10-6256-4049.

E-mail address: yonglin@cl.cryo.ac.cn (Y.L. Ju).

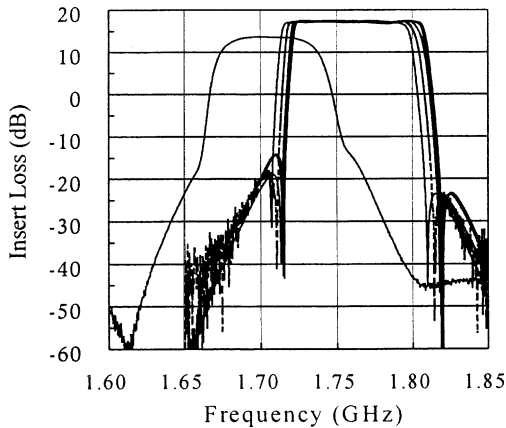

Fig. 1. Frequency responses of the HTS filters at different temperatures (from left to right: 86, 80, 77, 75, 71, 69 and 66 K).

GM coolers with separate compressors or by totally integrated Stirling coolers with linear compressors, which are regarded as matured technology and widely used in many areas. However, the vibrations caused by the moving displacer of GM and Stirling coolers are of the severe problems for the operation of high quality HTS devices.

Acceleration measurements [5,6] showed that the vibrations of the PTCs are one order of magnitude smaller than that of GM and Stirling coolers. Fig. 1 was the frequency responses of a HTS (YBCO thin film deposited on gem substrate) microwave filters cooled by a GM type coaxial PTC at different temperatures [7]. The central frequency moves gradually to low frequencies with increasing temperatures. The shift of the central frequency becomes obviously at temperature above 75 K, but the bandwidth and insert loss are nearly constant, except at temperatures up to 86 K. It has been proven that a properly designed PTC has great advantage and is capable of low-noise cooling of highly sensitive HTS devices. In this work, two special Stirling-type PTCs driven by a commercial dual piston linear compressor with sweep volume of 10 cc are designed for the purpose of developing a fully integrated, cryogen-free cooling HTS filter subsystems.

A computer simulation program [8] developed by the present author has been applied for performance prediction, optimization, and as a guide of system design. Our computer design approach

involves three stages. The first stage is of geometrical arrangement of the pulse tube and regenerator. There are three types, in-line type, U type and coaxial type. Obviously, the in-line arrangement has the highest efficiency [3]. However, the cold head located at the middle region of the two warm ends is the main disadvantage for connecting to the cooled devices. The most compact and convenient one for practical applications is the coaxial type. It can replace Stirling cooler without any change to the Dewar or the connection to the cooled devices. However, there are several inferior elements, like mismatch of temperature profiles between the regenerator and pulse tube, void space at the cold head, and the reversal of the gas flow direction in the cold head space, which retard the thermal efficiency. The second stage is to optimize cooler system with respect to dimensional layout of the pulse tube, regenerator, and heat exchangers based on the sweep volume of the compressor. Firstly, the cooler volume must be adjusted to match the sweep volume of the compressor in order to gain the proper pressure amplitude in the cold finger. Secondly, the volume ratio of the regenerator to pulse tube must be optimized to achieve a load balance. Thirdly, the arrangement of the regenerator matrix must be optimized based on the gas temperature profiles along the regenerator to reach a low no-load temperature. Finally, the heat exchange surface area per unit volume of the hot and cold heat exchangers must be high thermal linked between the cold head and cooled HTS devices, and for heat extract between the hot end and environments. The third stage is to choose optimal average pressure and frequency to gain the minimum power consumption at the same effective cooling capacity.

Quantitative analysis of single-stage coaxial PTC is first carried out by the computer simulation program, through which the power consumption and cooling capacity, the main system and operating parameters, could be evaluated. Fig. 2 shows the predicted performance of single-stage PTC as a function of the volumes of the regenerator and pulse tube to the 10 cc compressor at frequency of 50 Hz. The optimal design point of the regenerator and pulse tube is clearly found to achieve the maximum COP (cooling capacity divided by

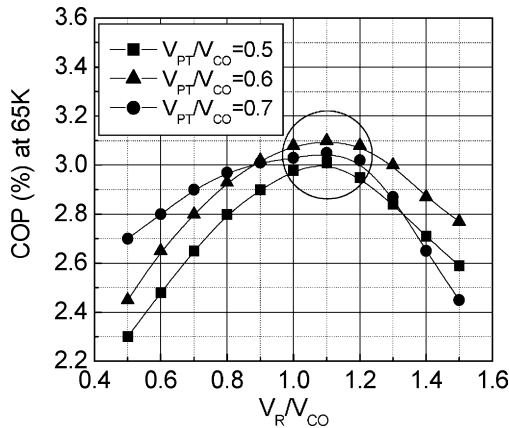

Fig. 2. COP as a function of regenerator volume and pulse tube volume of PTC.

PV-work) at 65 K. It shows that the optimum ratios of the regenerator and pulse tube volumes to the compressor volume are in the range of 1.0–1.2 and 0.5–0.7, respectively. At its most efficient operating point, the cooler provides 3.5 W at 65 K with a *PV*-work of 112 W and the corresponding COP of 3.1%. The specific power is 32 W/W, which is slightly lower than the design goal.

As an alternative approach, we proposed and analyzed a two-stage coaxial PTC, driven by the same linear compressor, to get minimal power consumption at the same effective cooling capacity of 3.5 W. Table 1 shows the optimization output of the two cooled fingers, which mainly differ by the dimensional layout. The two-stage PTC can provide 0.5 W at 65 K on the second-stage cold head with simultaneous 3.0 W on the first-stage cold head around 90 K with a specific *PV*-work of 73 W. The integral COP (sum of first and second

Table 1
Optimization outputs of two cold fingers

Parameters	Single stage	Two stage
Cold finger diameter (mm)	21	21 (1st) & 14 (2nd)
Cold finger length (mm)	85	60 (1st) & 35 (2nd)
Cooling capacity (W)	3.5	3 (1st) & 0.5 (2nd)
<i>PV</i> -work (W)	112	73
Specific power (W/W)	32	21
COP (%)	3.1	4.8

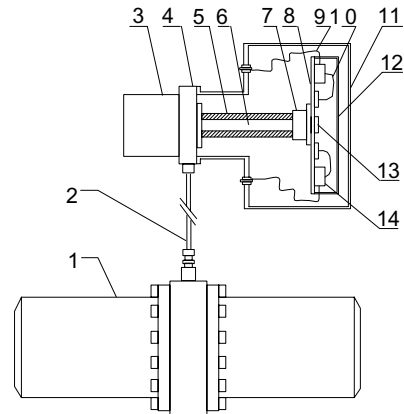

Fig. 3. The construction of the cooled HTS filters integrated with single-stage PTC.

stages cooling capacity divided by *PV*-work) is up to 4.8% and the specific power is 21 W/W. Comparison of optimization parameters shows that the specific *PV*-work is saving about 35% and the heat generated by the compressor is decreasing about 30% by using the two-stage cold finger than the single-stage configuration.

Fig. 3 is the schematic of the single-stage coaxial PTC, which consists of a compressor (1), a flexible connection tube (2), an integrated gas buffer (3), a hot end flange (4), on which the hot ends of the pulse tube and regenerator are mounted, a regenerator (5), a pulse tube (6) and a cold head (7). The regenerator is made of thin-walled stainless steel tube filled with 400-mesh stainless steel screen. The pulse tube is made of Teflon with a wall thickness of 0.6 mm and is placed within the annular regenerator. The cold head consists of a copper base platform on which the HTS filters can be easily coupled.

Besides the cooler itself, it is also essential to design and provide cryopackage, which is the means of high degree of integration (thermally, mechanically and electronically) of the cold finger to the HTS filters within an evacuated chamber while providing electronically connections through the vacuum space. The cryopackage should be reliable, adequate integration with HTS filter subsystems and easy fabrication. The construction of the cooled HTS filters integrated with the single-stage PTC is also illustrated in Fig. 3, which is

arranged to operate at a temperature of about 65 K in order to meet the demands of HTS filters cooling. An array of LNAs (14), RF filters (13) and radiation shield (12) are thermally mounted on a copper base platform (8), which is anchored to the single cold head (7) of the cooler through thin indium foils with high thermal conductivity. The whole construction is placed in a vacuum chamber (11), which provides the electrical connections of the RF filters, LNA array and vacuum feedthrough carried out by coaxial cables (9,10). The advantage of such design is of the simple construction of the cooler and HTS filter subsystem. The disadvantages lie in the high power required to operate the cooler, and in cooling the radiation shield and the LNA array to a temperature lower than necessary, resulting in the fact that these components contribute most of the cooling capacity. In addition, the cooling-down time of the cooler is delayed at start up in achieving the operation temperature required by the filters during the time it is extracting heat from the LNAs and radiation shield.

In order to overcome the disadvantages of the above cooler design, the HTS filter subsystem have been integrated with the two-stage coaxial PTC (Fig. 4), equipped with the same linear compressor unit and with two cold heads operated at different cryogenic temperatures. The construction allows simultaneous cooling of HTS RF filters and LNA array to different specific cryogenic temperatures, which are sufficient for their operation. The RF filters (13) are mounted on a copper base platform thermally coupled to the second-stage cold head (15), which is set to operate at a temperature of 65 K in order to meet the demands of the RF filters cooling. Both the LNA array (14) and radiation shield (12) are mounted on another copper base platform (8) thermally coupled with the first-stage cold head (7), which is arranged to operate at around 90 K. Such a design of the cryopackage allows the HTS RF filters and LNAs to operate at

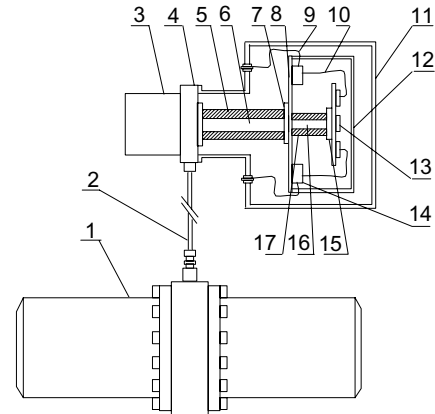

Fig. 4. The construction of the cooled HTS filters integrated with two-stage PTC.

their different sufficient specific temperatures, resulting in reducing the power consumption and increasing cooler reliability. In addition, the two-stage configuration is capable of accommodating large HTS devices and the necessary electronic circuits, and the HTS filter subsystems construction is more rigid than the single-stage option.

Acknowledgement

The work is funded by the National Natural Science Foundation (grant no. 50176052).

References

- [1] A.I. Braginski, *IEEE Trans. Appl. Supercond.* 9 (1999) 91.
- [2] J.L. Martin et al., *Cryocoolers* 10 (1999) 181.
- [3] E. Tward et al., *Cryocoolers* 11 (2001) 163.
- [4] E.D. Marquardt, R. Radebaugh, *Adv. Cryo. Eng.* 45 (2000) 629.
- [5] H. Li et al., *Physica C* 282–287 (1997) 2527.
- [6] Y. He et al., *IEEE Trans. Appl. Supercond.* 9 (1999) 3569.
- [7] K. Yuan, MS thesis, Chinese Academy of Sciences, 2002.
- [8] Y.L. Ju, *Cryogenics* 41 (2001) 49.