

Design of Cryogen-free Operation of HTS Filter Subsystem with Co-axial Pulse Tube Cryocoolers

Ju Y. L. Yuan K. Hou Y. K. Jing W. Liang L. J. and Zhou Y.

Technical Institute of Physics and Chemistry, Chinese Academy of Sciences, Beijing 100080, China

ABSTRACT

In view of the present trend of developing high frequency Stirling type pulse tube cooler with large-scale cooling capacity at liquid nitrogen temperatures for cooling of HTS RF filters for wireless telecommunications, we report here on system design of Stirling type co-axial pulse tube cryocoolers (PTCs) for the purpose of developing a fully integrated, cryogen-free operation of HTS RF filter subsystems. Two different co-axial cold finger geometries of single-stage and two-stage pulse tube coolers are proposed, analyzed and designed. The design objective of the coolers is for 3.5W of cooling capacity at 65K with a specific power of 30W/W.

INTRODUCTION

The developments of high frequency Stirling type pulse tube cryocooler with large-scale cooling capacity at liquid nitrogen temperatures is highly desirable for cooling of infrared sensor and of HTS devices, i.e. high quality RF filters in ground base stations for wireless telecommunications^[1,2]. In order to improve the voice transmission quality by reducing inter-channel EMI of cellular phone systems, the HTS RF filters integrated with an array of Low Noise Amplifiers (LNAs) are commonly used. The HTS filters are passive devices and must be cooled below their transition temperature (usually 65-80K) in order to operate properly. The HTS filters are usually connected through a coaxial cable to the LNAs, which are active devices and induce a few hundreds milliwatts of thermal load. The signal-to-noise ratio of LNAs is improved significantly when cooled to 90~110K. Cooling is being performed either by GM coolers with separate compressors or by totally integrated Stirling coolers with linear compressors. However, the vibrations caused by the moving displacer of GM and Stirling coolers are of the severe problems for the operation of high quality HTS devices.

Due to the intrinsic low vibrations and EMI noise owing to without mechanical moving parts at low temperatures, pulse tube cryocoolers (PTCs) have been approved as promising candidates for the low noise cooling of superconducting devices. In the past decade the progress in PTCs has been impressive. Many new ideas, incorporated with refined thermo-mechanical design and fabrication, lead to significant improvements in thermal efficiency^[3,4]. Experiments with capacitive accelerometers and Dynamic Signal Analyzer have been carried out to measure the transverse and longitudinal acceleration of different types of PTCs^[5,6], which showed that the vibrations of the PTCs are at least an order of magnitude smaller than that of GM and Stirling coolers. Fig.1 showed the frequency responses of a HTS (YBCO thin film deposited on gem substrate) microwave filters cooled by a G-M type PTC at different temperatures^[7]. The central frequency moves gradually to low frequencies with increasing temperatures. The shift of the central frequency becomes obviously at temperature above 75K, but the bandwidth and insert loss are nearly constant, except at

temperature up to 86K. It has been proven that a properly designed PTC has great advantage and is capable of low-noise cooling of highly sensitive HTS devices. In this work, two special Stirling-type PTCs driven by a commercial linear compressor are designed for the purpose of developing a fully integrated, cryogen-free cooling HTS filter subsystems.

THEORETICAL OPTIMIZATION

A computer simulation program [8] developed by the present author has been applied for performance prediction, optimization, and as a guide of system design. Our computer design approach involves three phases. Phase one is of geometrical arrangement of pulse tube and regenerator. We use the co-axial configuration, which is of the most compact and convenient for practical application, and can replace Stirling cooler without any change to the Dewar or the connection to the cooled devices. Phase two is to optimize cooler system with respect to dimensional layout of the pulse tube, regenerator, and heat exchangers based on the swept volume of the compressor. Firstly, the cooler volume must be adjusted to match the swept volume of the compressor in order to gain the proper pressure amplitude in the cold finger. Secondly, the volume ratio of the regenerator to pulse tube must be optimized to achieve a load balance. Thirdly, the arrangement of the regenerator matrix must be optimized based on the gas temperature profiles along the regenerator to reach a low no-load temperature. Finally, the heat exchange surface area per unit volume of the hot and cold heat exchangers must be high thermal linked between the cold head and cooled HTS devices, and for heat extract between the hot end and environments. The third phase is to choose optimal charge pressure and frequency to gain the minimum power consumption at the same effective cooling capacity.

Quantitative analysis of single-stage co-axial PTC is first carried out by the computer simulation program, through which the power consumption and cooling capacity, the main system and operating parameters, could be evaluated. Fig. 2 shows the predicted performance of single-stage PTC as a function of the volumes of the regenerator and pulse tube to the 10cc compressor at frequency of 50Hz. The optimal design point of the regenerator and pulse tube is clearly found to achieve the maximum COP (cooling capacity divided by PV-work) at 65K. It shows that the optimum ratios of the regenerator and pulse tube volumes to the compressor volume are in the range of 1.0-1.2 and 0.5-0.7, respectively. At its most efficient operating point, the cooler provides 3.5W at 65K with a PV-work of 112W and the corresponding COP of 3.1%. The specific power is 32W/W, which is slightly lower than the design goal.

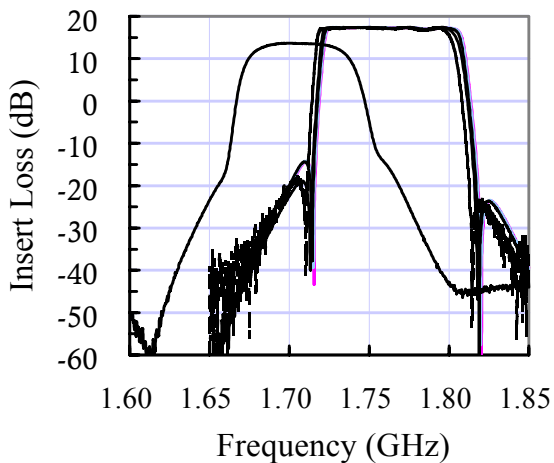

Figure 1 Frequency responses of HTS filters (from left to right: 86K, 80K, 75K, 71K, 69K and 66K)

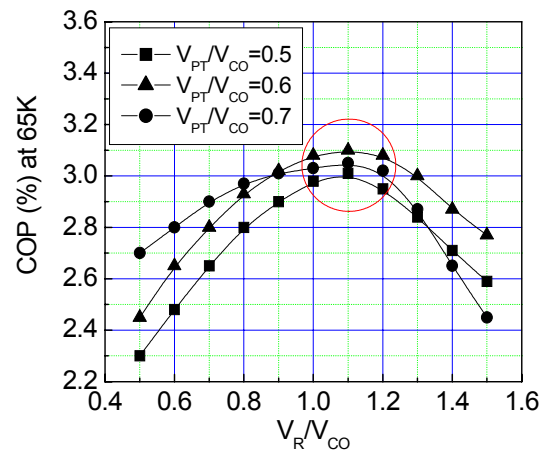

Figure 2 COP as a function of regenerator volume and pulse tube volume of PTC

Table 1 Optimization outputs of two cold fingers

Parameters	Single-stage	Two-stage
Cold finger diameter, mm	21	21 (1 st) & 14 (2 nd)
Cold finger length, mm	85	60 (1 st) & 35 (2 nd)
Cooling capacity, W	3.5	3 (1 st) & 0.5 (2 nd)
PV-work, W	112	73
Specific power, W/W	32	21
COP, %	3.1	4.8

As an alternative approach, we proposed and analyzed a two-stage co-axial PTC, driven by the same linear compressor, to get minimal power consumption at the same effective cooling capacity of 3.5W. Table 1 shows the optimization output of the two cooled fingers, which mainly differ by the dimensional layout. The two-stage PTC can provide 0.5W at 65K on the 2nd-stage cold head with simultaneous 3.0W on the 1st-stage cold head around 90K with a specific PV-work of 73W. The integral COP (sum of 1st and 2nd stages cooling capacity divided by PV-work) is up to 4.8% and the specific power is 21W/W. Comparison of optimization parameters shows that the specific PV work is saving about 35% and the heat generated by the compressor is decreasing about 30% by using the two-stage cold finger than the single-stage configuration.

SYSTEM DESIGN CONSIDERATIONS

Fig. 3 is the schematic of the single-stage co-axial PTC, which consists of a compressor (1), a flexible connection tube (2), an integrated gas buffer (3), a hot end flange (4), on which the hot ends of the pulse tube and regenerator are mounted, a regenerator (5), a pulse tube (6) and a cold head (7). The regenerator is made of thin-walled stainless steel tube filled with 400-mesh stainless steel screen. The pulse tube is made of Teflon with a wall thickness of 0.6mm and is placed within the annular regenerator. The cold head consists of a cooper base platform on which the HTS filters can be easily coupled.

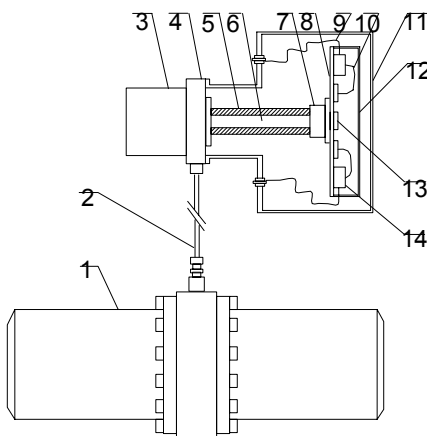

Fig. 3. The construction of the cooled HTS filters integrated with single-stage PTC

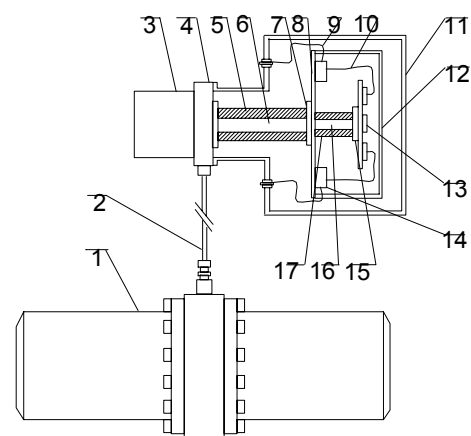

Fig. 4. The construction of the cooled HTS filters integrated with two-stage PTC

Besides the cooler itself, it is also essential to design and provide cryopackage, which is the means of high degree of integration (thermally, mechanically and electronically) of the cold finger to the HTS filters within an evacuated chamber while providing electronically connections through the vacuum space. The cryopackage should be reliable, adequate integration with HTS filter subsystems and easy fabrication. The construction of the cooled HTS filters integrated with the single-stage PTC is also illustrated in Fig. 3, which is arranged to operate at a temperature of about 65K in order to meet the demands of HTS filters cooling. An array of LNAs (14), RF filters (13) and radiation shield (12) are thermally mounted on a copper base platform (8), which is anchored to the single cold head (7) of the cooler through thin indium foils with highly thermal conductivity. The whole construction is placed in a vacuum chamber (11), which provides the electrical connections of the RF filters, LNA array and vacuum feedthrough carried out by coaxial cables (9,10). The advantage of such design is of the simple construction of the cooler and HTS filter subsystem. The disadvantages lie in the high power required to operate the cooler, and in cooling the radiation shield and the LNA array to a temperature lower than necessary, resulting in the fact that these components contribute most of the cooling capacity. In addition, the cooling-down time of the cooler is delayed at start up in achieving the operation temperature required by the filters during the time it is extracting heat from the LNAs and radiation shield.

In order to overcome the disadvantages of above cooler design, the HTS filter subsystem have been integrated with the two-stage co-axial PTC (Fig.4), equipped with the same linear compressor unit and with two cold heads operated at different cryogenic temperatures. The construction allows simultaneous cooling of HTS RF filters and LNA array to different specific cryogenic temperatures, which are sufficient for their operation. The RF filters (13) are mounted on a copper base platform thermally coupled to the second-stage cold head (15), which is set to operate at a temperature of 65K in order to meet the demands of the RF filters cooling. Both the LNA array (14) and radiation shield (12) are mounted on another copper base platform (8) thermally coupled with the first-stage cold head (7), which is arranged to operate around 90K. Such design of the cryopackage allows the HTS RF filters and LNAs to operate at their different sufficient specific temperatures, resulting in reducing the power consumption and increasing cooler reliability. In addition, the two-stage configuration is capable of accommodating large HTS devices and the necessary electronic circuits, and the HTS filter subsystems construction is more rigid than the single stage option.

ACKNOWLEDGMENT

The work is funded by the National Natural Science Foundation of China (Grant No. 50176052)

REFERENCES

1. Braginski A. I., Superconducting electronics coming to Market. IEEE Trans. Appl. Supercond (1999) 9, 91
2. Martin J.L. et al. Design consideration for industrial cryocoolers, Cryocoolers (1999) 9,181
3. Tward E. et al. High efficiency pulse tube cooler, Cryocoolers (2001) 11, 163
4. Marquardt E. D. and Radebaugh, R., Pulse tube oxygen liquefier, Adv.Cryo.Eng. (2000) 45, 629
5. Li H. et al. Demonstration of HTS microwave sub-systems with a pulse tube cryocooler. Physica C (1997) 282, 2527
6. He Y. S. et al. HTS microwave devices and subsystems with pulse tube refrigerator, IEEE Trans. Appl. Supercond. (1999) 9, 3569
7. Yuan K., MS thesis, Chinese Academy of Sciences, 2002
8. Ju Y. L., Computational study of a 4K two-stage pulse tube cooler with mixed Eulerian-Lagrangian method, Cryogenics (2001) 41, 49