

---

# Jet Physics in HI Collisions with the ATLAS Detector

---

Nathan Grau,  
Columbia University, Nevis Labs



# The ATLAS HI Working Group

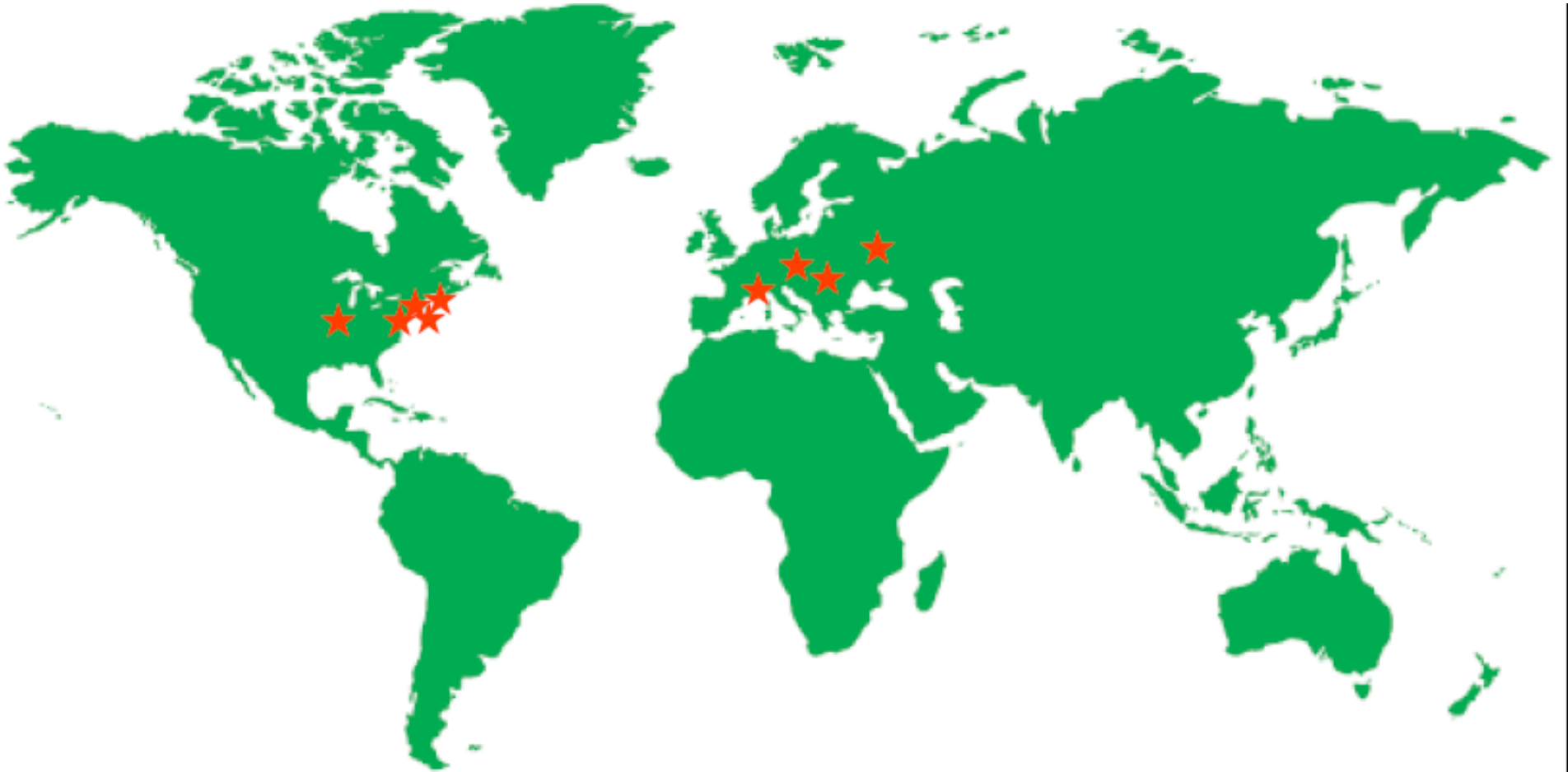

BNL, Columbia, Dubna, Iowa State, INP (Krakow), Charles U(Prague),  
SUNYSB, University of Geneva, Yale (HEP)

# Outline

- Overview of relevant physics studied by ATLAS
  - i.e. what do we know from RHIC
- Overview of the ATLAS detector and its capabilities
  - Tracking
  - B-tagging
  - Calorimetry
- Jet measurement capabilities
  - Old and new results
- Beyond Pb+Pb



# The physics of HIC at LHC

- Build on the strong base of work done at RHIC
  - Strongly-coupled QGP (sQGP)
    - Azimuthal anisotropy is large at high- $p_T$
    - Single particle suppression is large at high- $p_T$ 
      - $\pi^0$ , K,  $\Lambda$ ,  $\phi$ ,  $J/\psi$ , e, etc.
    - Two-particle azimuthal correlations
      - Away-side suppression and shape modification
  - Color Glass Condensate
    - Slow rise of  $dN/d\eta$  with energy in Au+Au
    - Single particle suppression at forward rapidity in d+Au
    - Mono-jet production at forward rapidity in d+Au



# Jet Quenching at RHIC: Singles

- Dramatic quenching relative to binary-scaled p+p is observed

$$\frac{dN^g}{dy} \approx 1000 \quad \hat{q}L \approx 15 \text{ GeV}^2$$

- Shape of  $R_{AA}$  is not sensitive to the details of energy loss

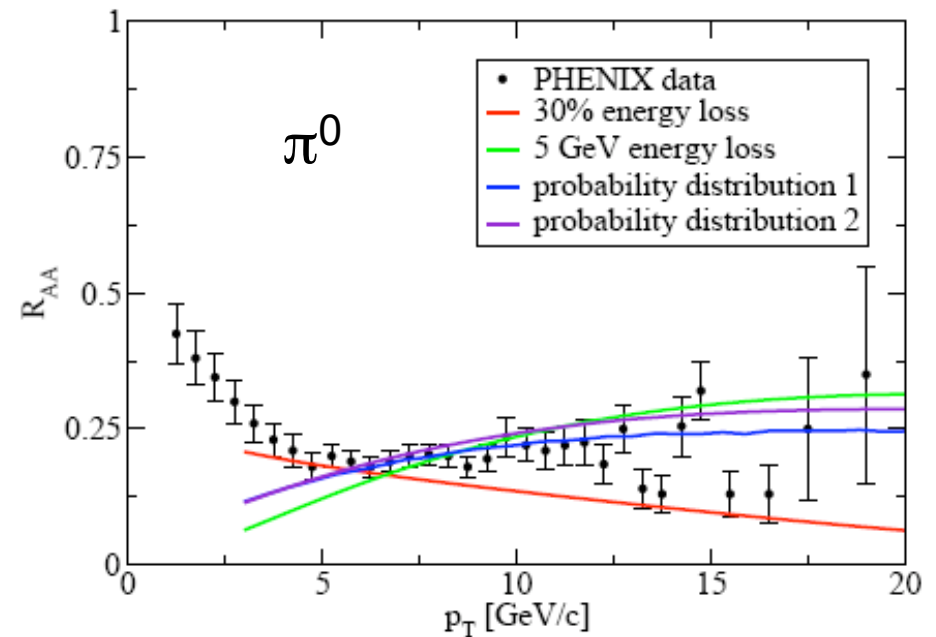
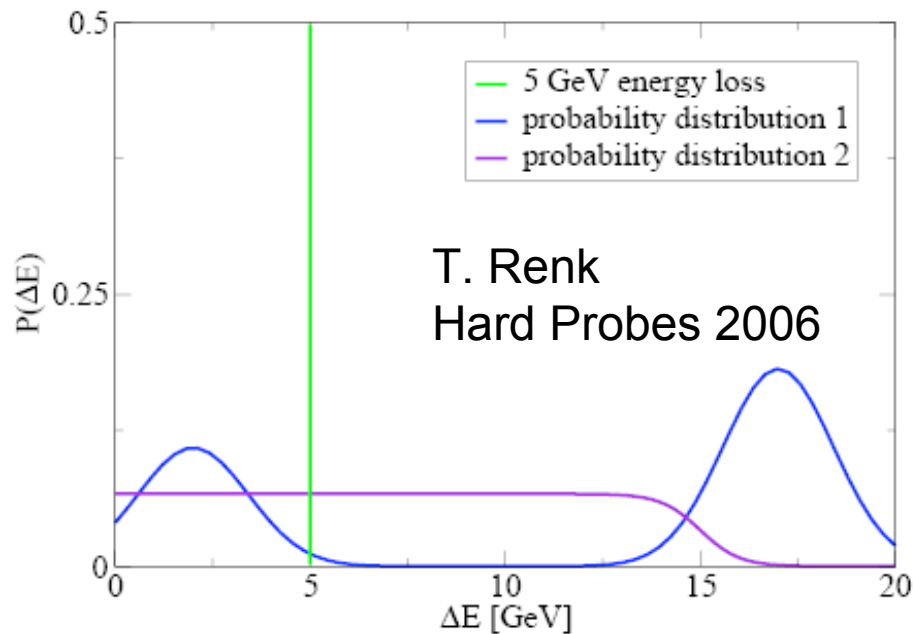

# Jet Quenching at RHIC: Pairs

- Two-particle away-side yields are suppressed but not

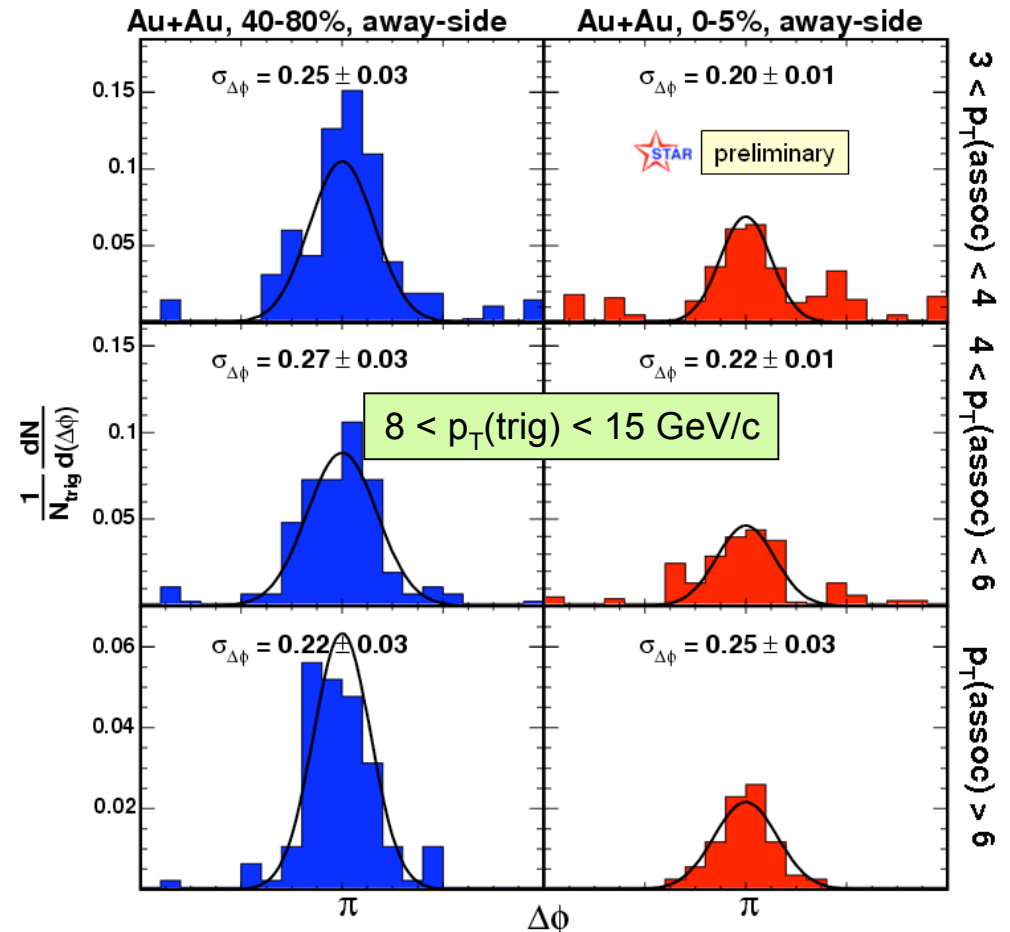
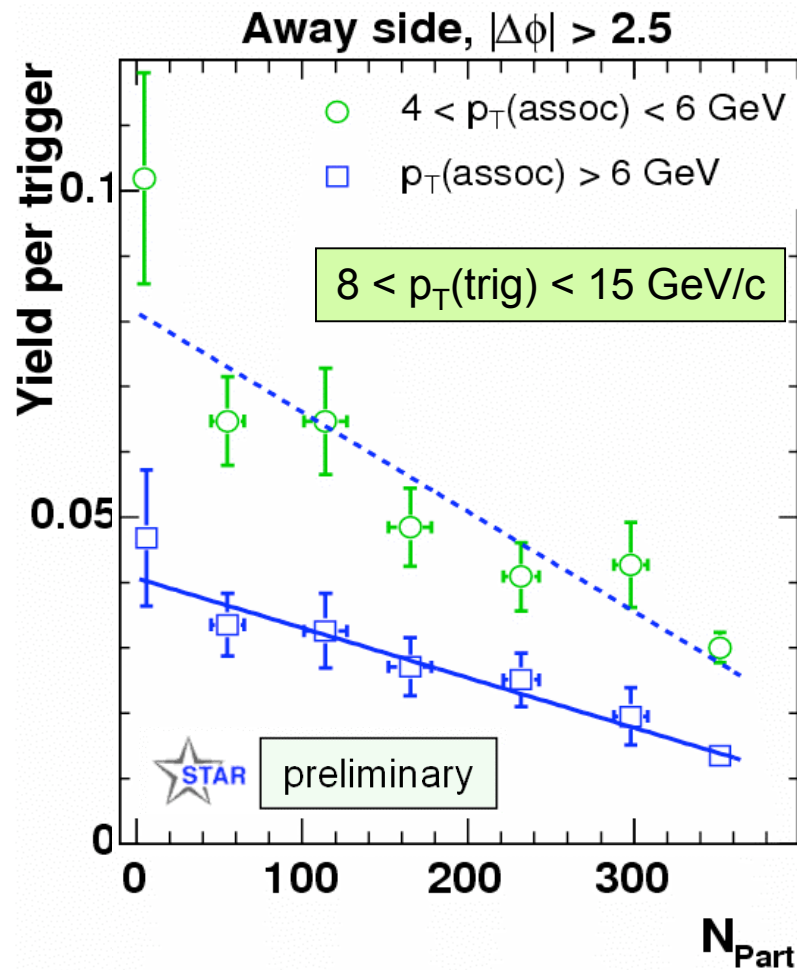

# Jet Quenching at RHIC: Heavy Quarks

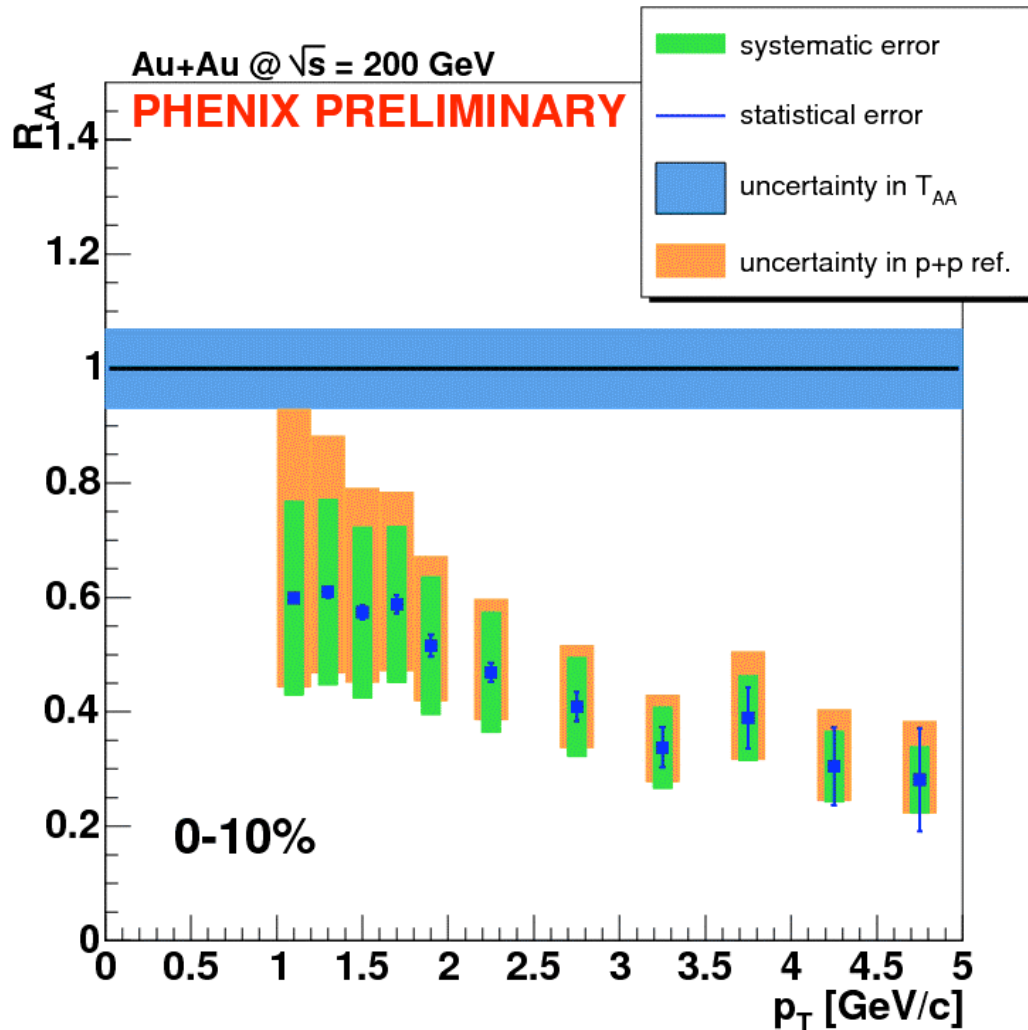

- Non-photonic electrons are largely suppressed
- Unexpected because of the dead-cone effect



# CGC at RHIC: $dN/d\eta$ in d+Au

- Suppression of single particles at forward rapidity in d+Au
- Shadowing == CGC?

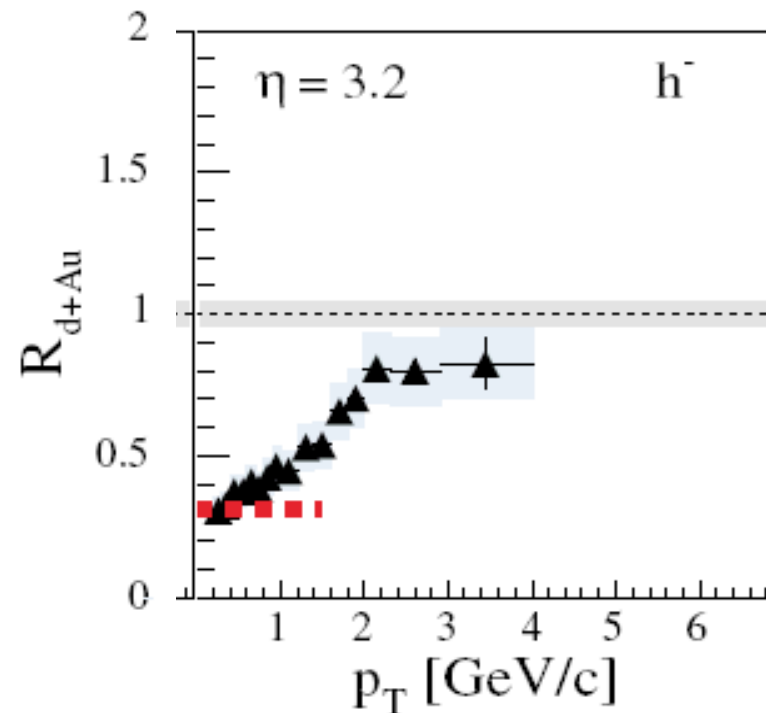
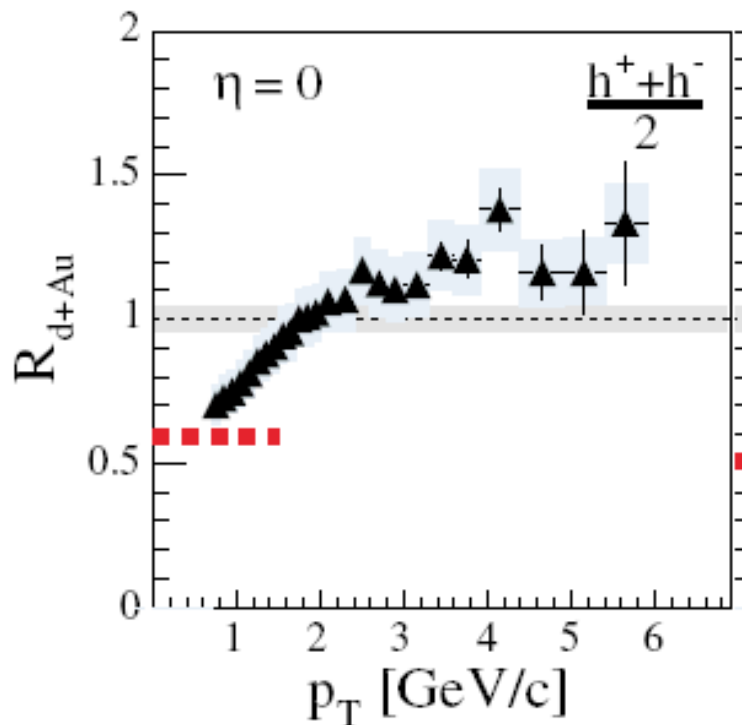

Nathan Grau

9/4/2006



# CGC at RHIC: Mono-jets in d+Au

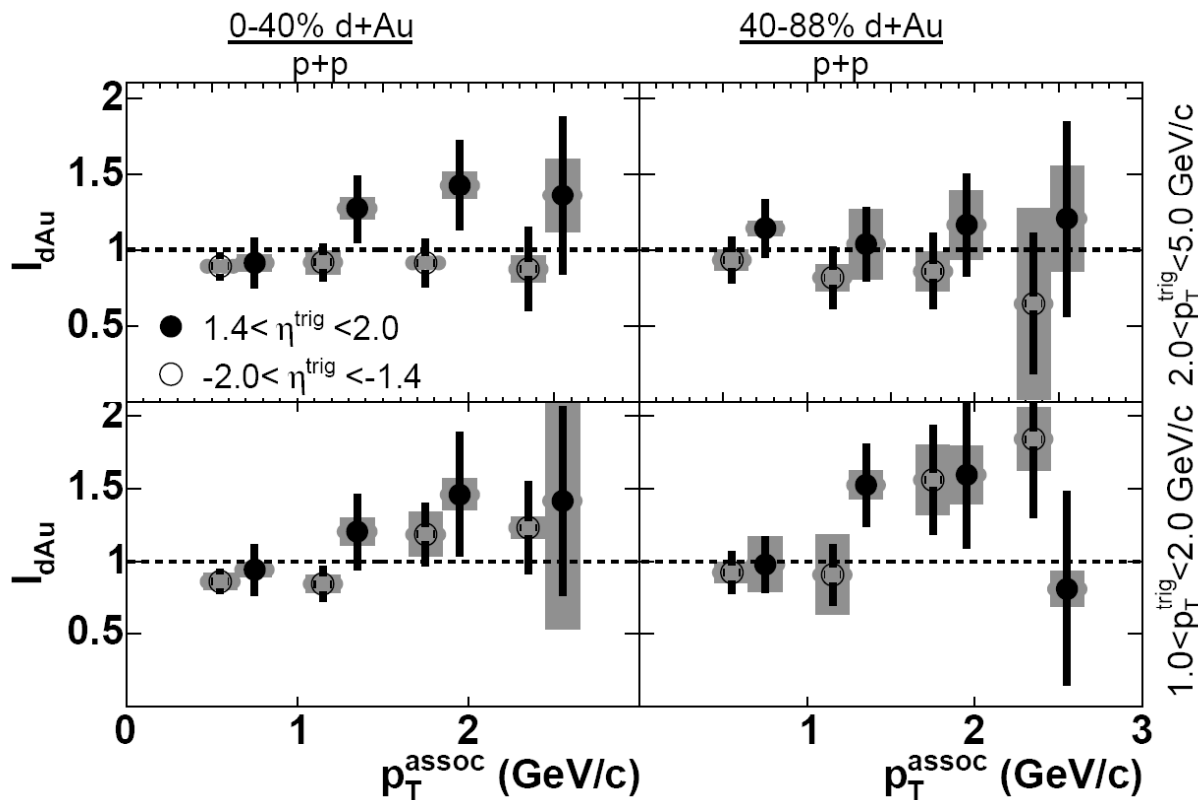

- Yield from h-h correlations trigger in the muon arm
- No suppression of the yield seen at  $\eta > 0$



# Motivation for Jet Physics at LHC

- Strong quenching is observed in singles and in pairs at RHIC
  - But no indication of multiple scattering
  - No light vs. heavy quark difference
  - No clear details of the energy loss exist
- Possible evidence for CGC at forward rapidity at RHIC
  - Forward suppressed production in d+Au
  - No clear mono-jet signal
- At LHC full jet reconstruction is possible
  - Removes the bias due to leading particles
  - Large detectors which cover larger  $\eta$
  - Searches for single and multiple jets in A+A: test energy loss
  - Searches for mono-jets in A+A and p+p: test for CGC



---

# The ATLAS Detector



# The ATLAS Detector (I)



## Detector characteristics

**Width:** 44m  
**Diameter:** 22m  
**Weight:** 7000t

CERN AC - ATLAS V1997

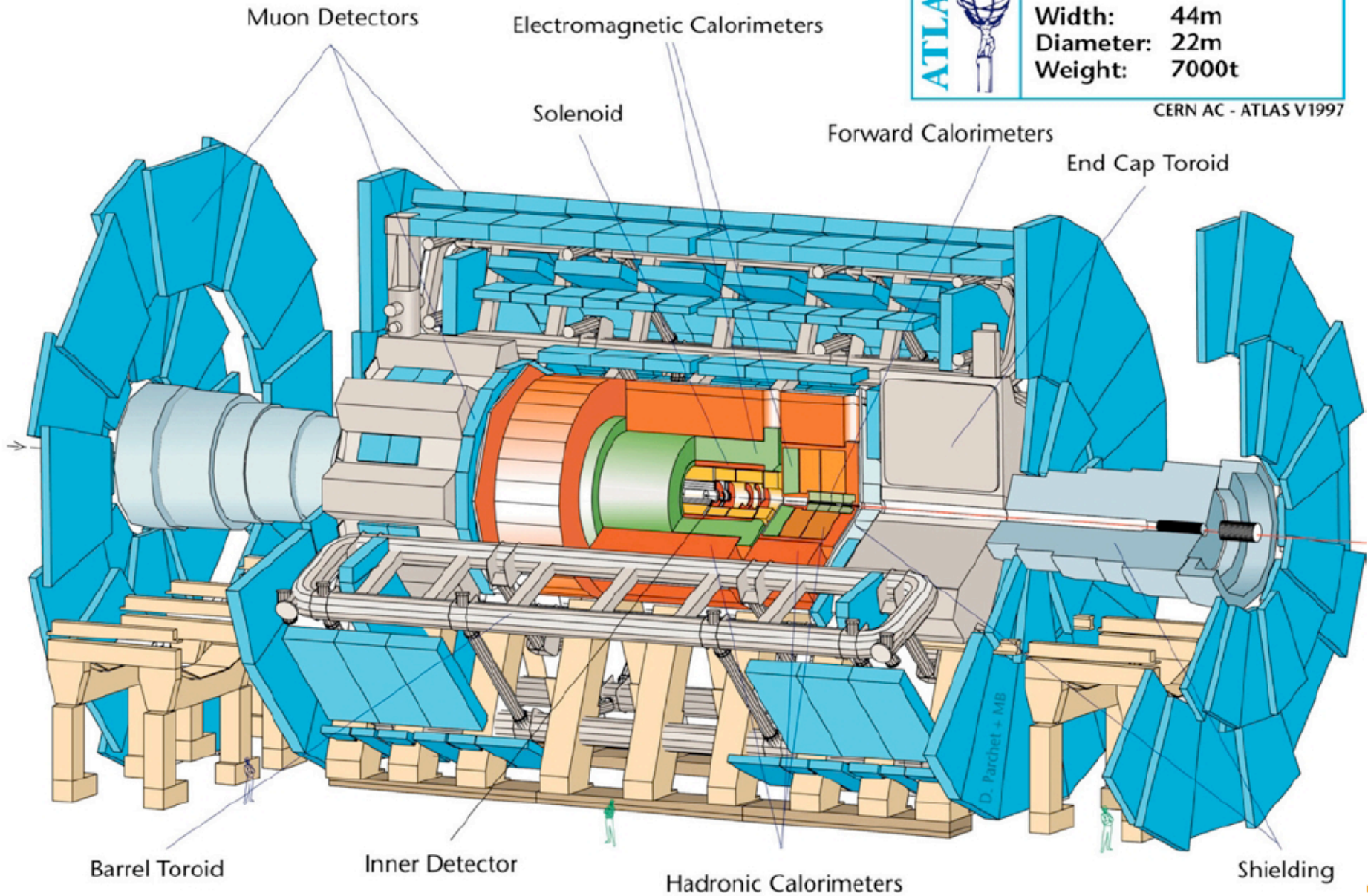

# The ATLAS Detector (II)

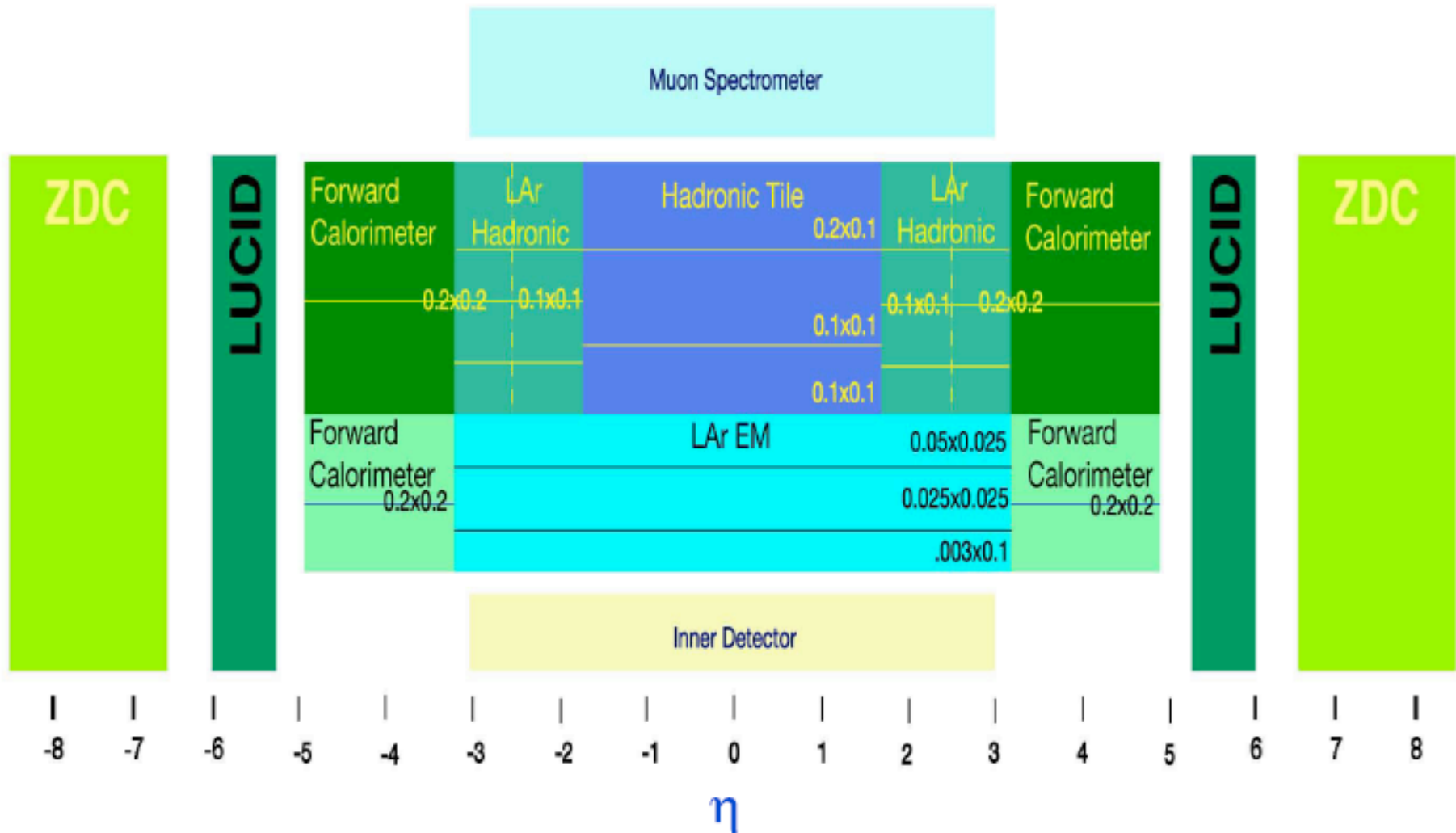

UX15 Geneva Sun Sep 3 15:00:01 2006

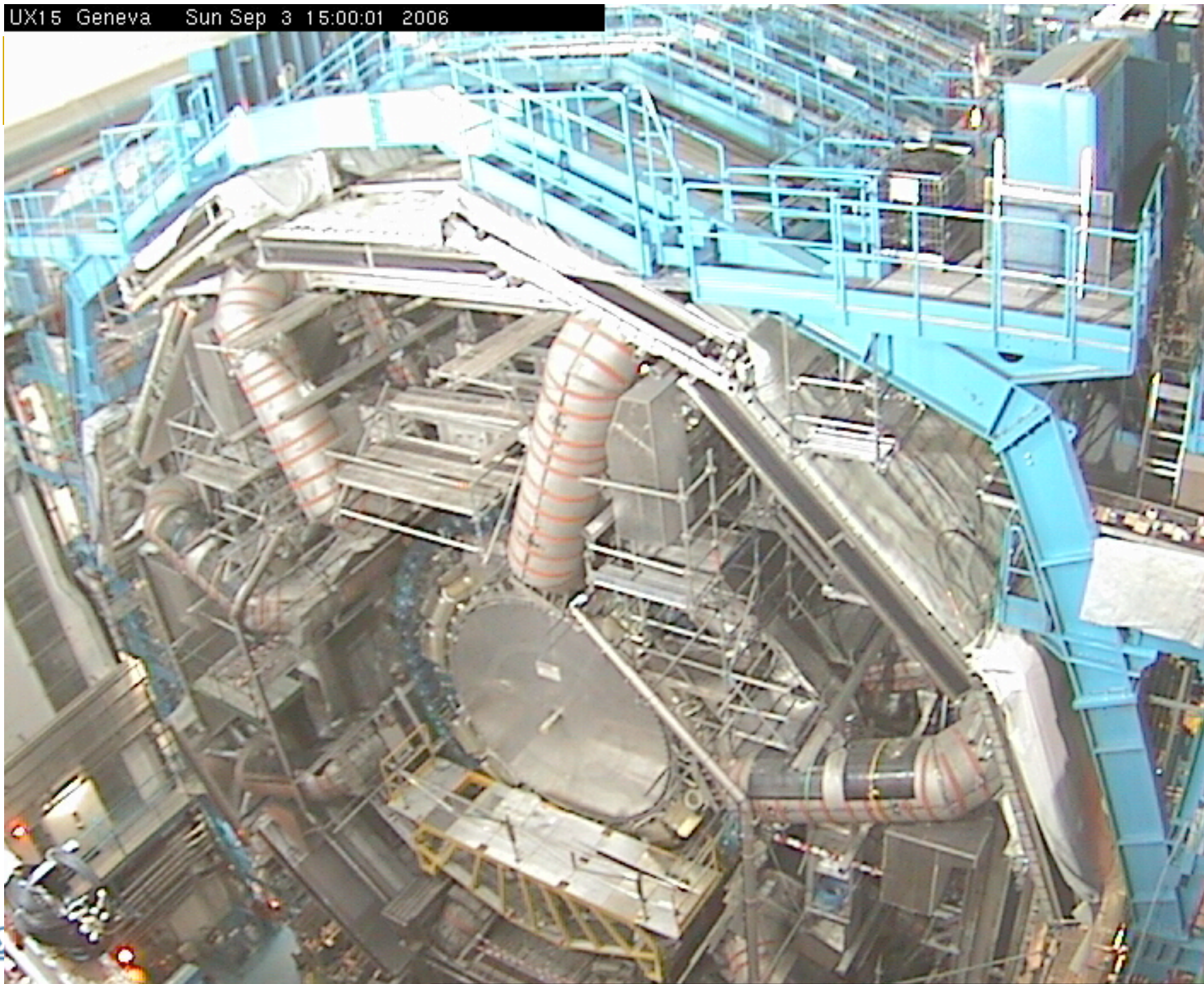

# Tracking with the Inner Detector

- Inner detector has full azimuthal coverage within  $|\eta| < 2.5$  and consists of
  - Pixel detector
  - Silicon tracking detector
  - Transition radiation tracker
    - For HIJING multiplicity, occupancy is too large in central Pb+Pb
- Results from p+p tracking algorithm, work ongoing to optimize for HI environment.
- Ongoing work to track below  $p_T$  of 0.5 GeV/c

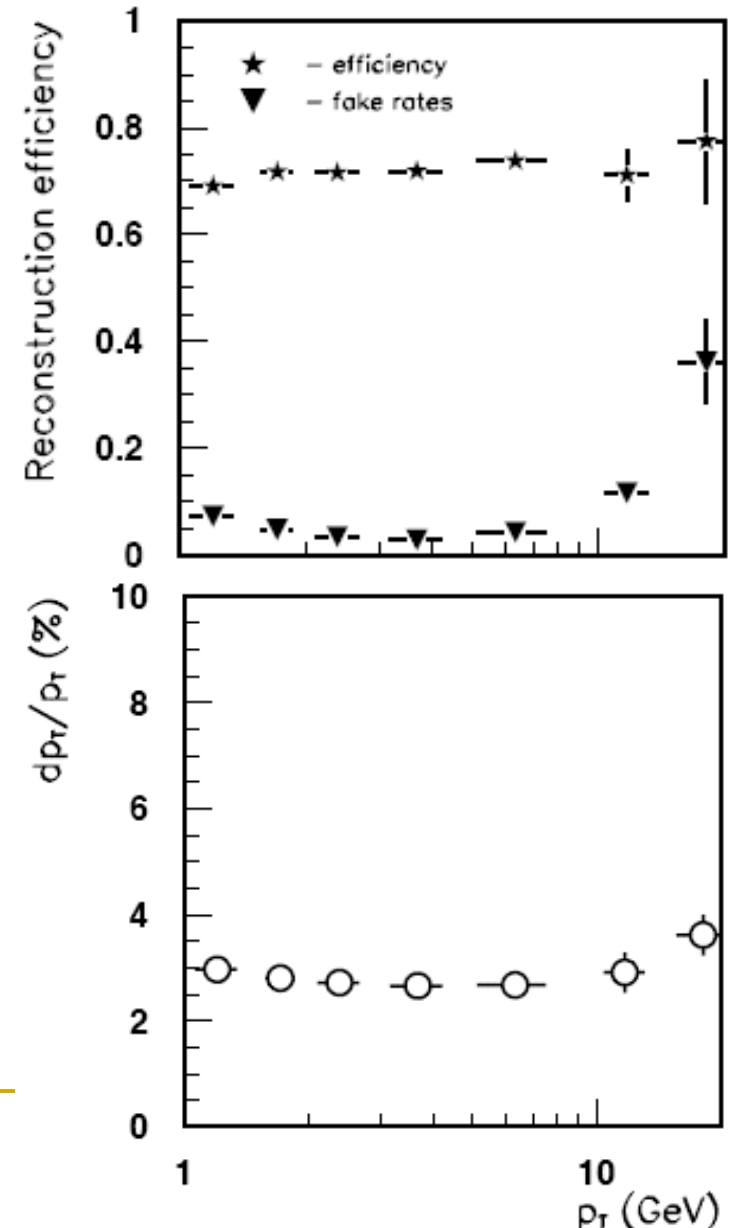

# b-tagging

- Analyzed  $p + p \rightarrow WH \rightarrow \ell \bar{\nu} b \bar{b}$  events embedded in HIJING  $p + p \rightarrow WH \rightarrow \ell \bar{\nu} u \bar{u}$  events embedded in
- Tagged the b by displaced vertex using p+p algorithm
- Also tag jets with high- $p_T$  muon

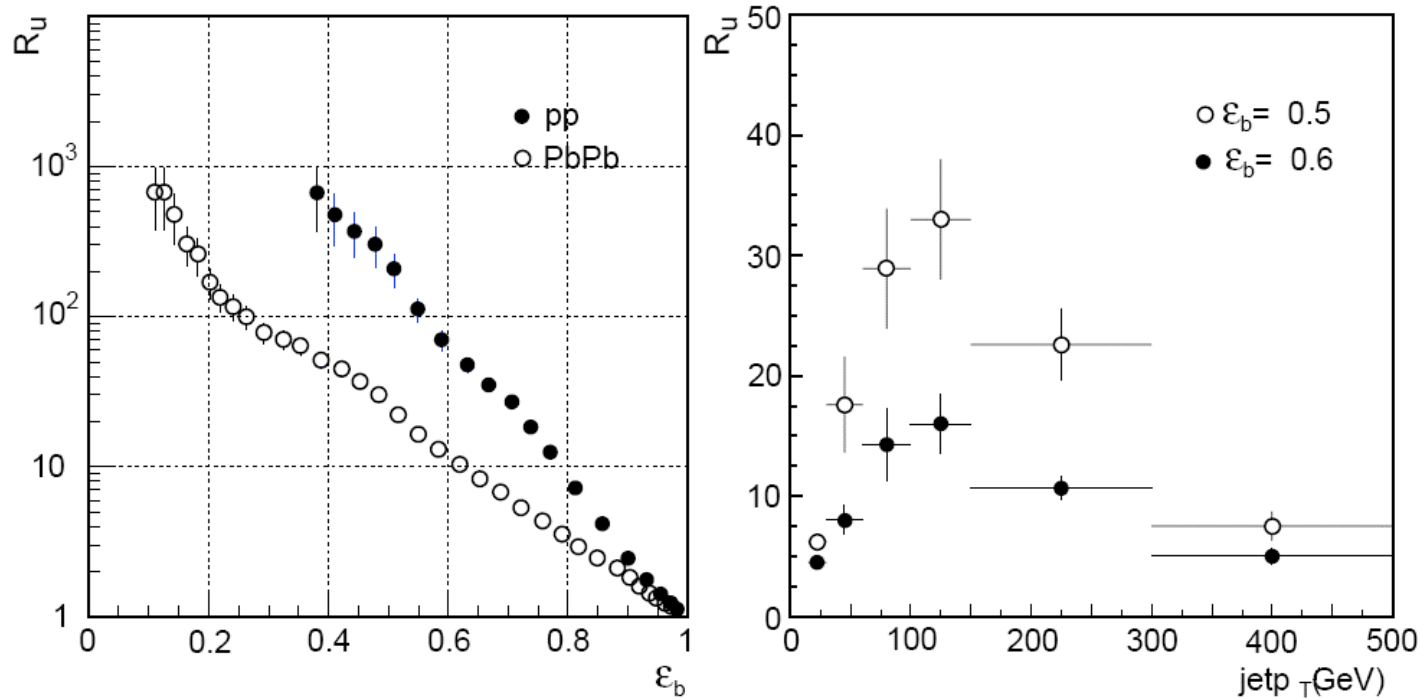

# ATLAS Calorimetry

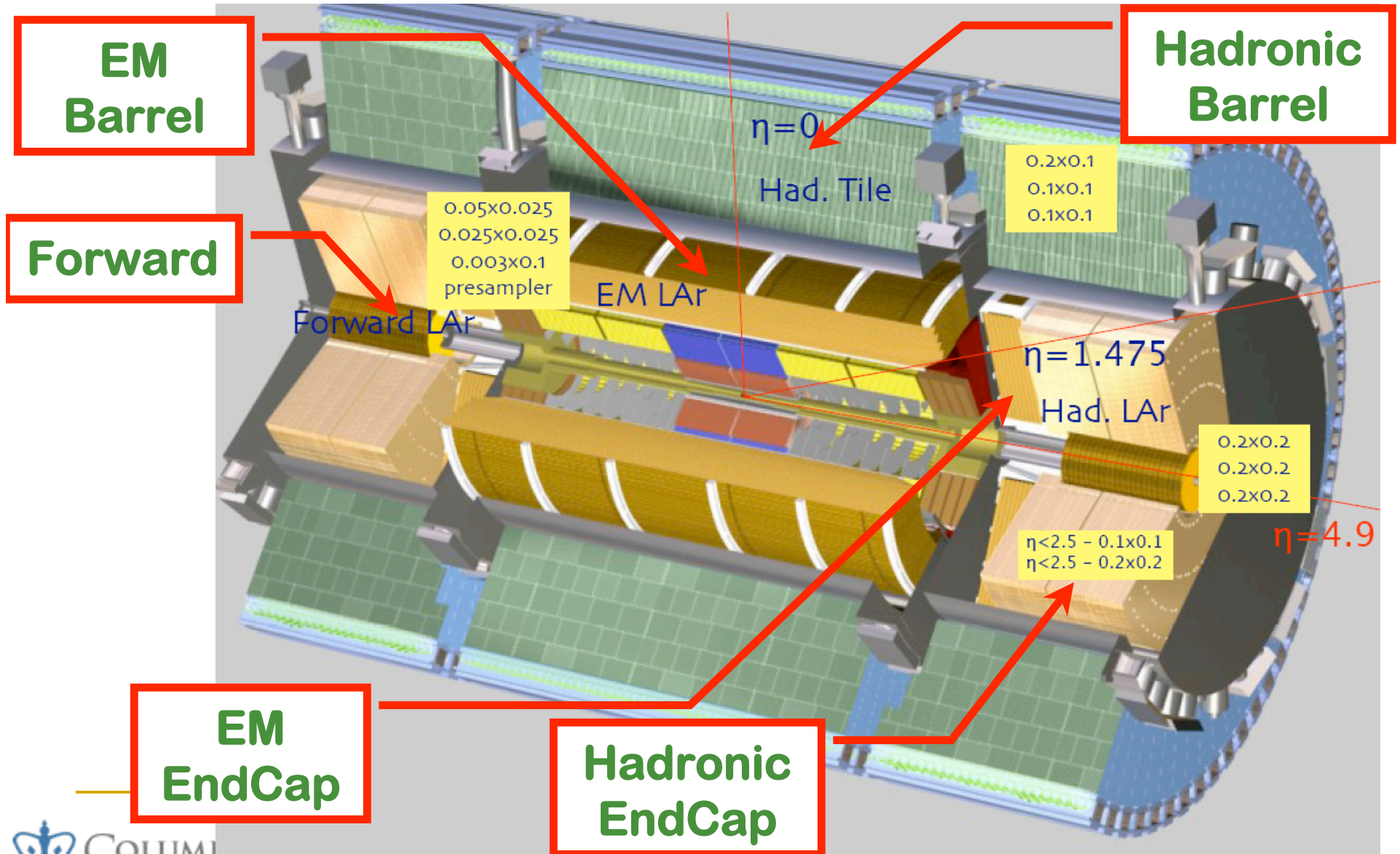

# Details of ATLAS Calorimetry

- Large acceptance:
  - hadronic  $|\eta| < 4.9$ , EM  $|\eta| < 3.2$
  - Three sections: barrel ( $|\eta| < 1.5$ ) endcap ( $1.5 < |\eta| < 3.2$ ) and forward ( $3.2 < |\eta| < 4.9$ )
  - Full azimuthal coverage in all sections.
- Segmentation (typical)
  - EM calorimeter:  $0.025 \times 0.025$
  - Hadronic calorimeter:  $0.1 \times 0.1$
- Both barrel and endcap calorimeters longitudinally segmented with three sections
- Forward calorimeter has two longitudinal sections
- Barrel EM first layer has fine  $\eta$  segmentation
  - Strips with  $\eta$  width 0.003



# Segmentation: 3-d Jets

Sampling of a 100 GeV jet (no background)

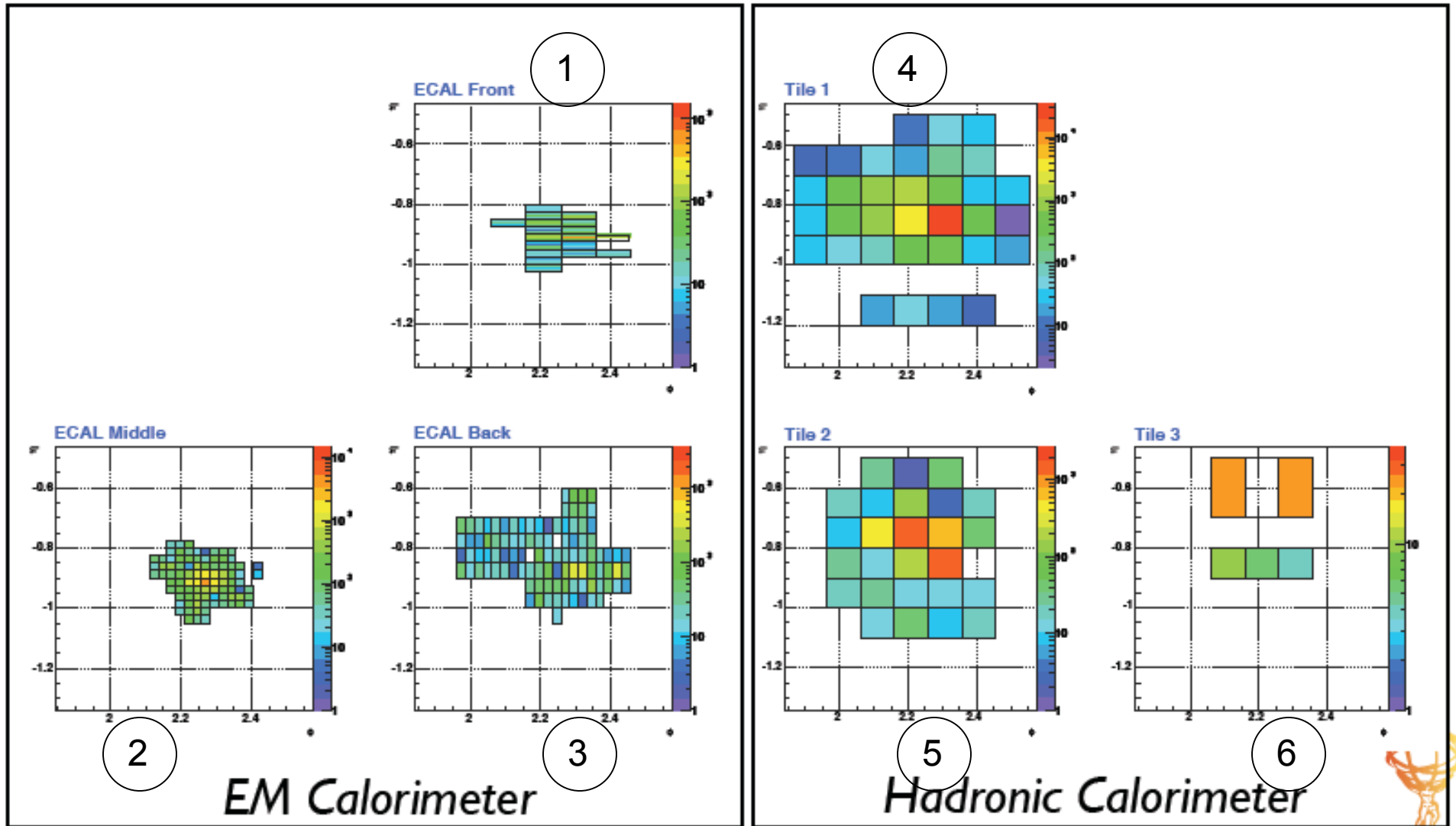

# Segmentation: Photons

- First EMCal Barrel layer ( $|\eta| < 1.5$ ) finely segmented in  $\eta$
- Useful in  $\gamma/\pi^0$  rejection for  $H \rightarrow \gamma\gamma$  searches
- Useful for tagging  $\gamma$  from jets/ $\pi^0$  in Pb+Pb

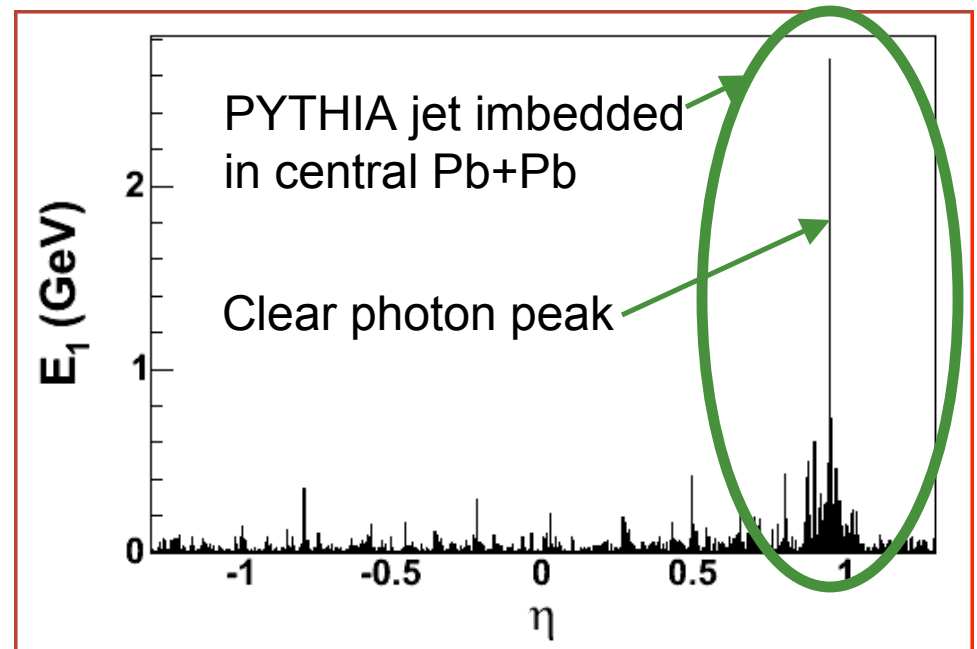
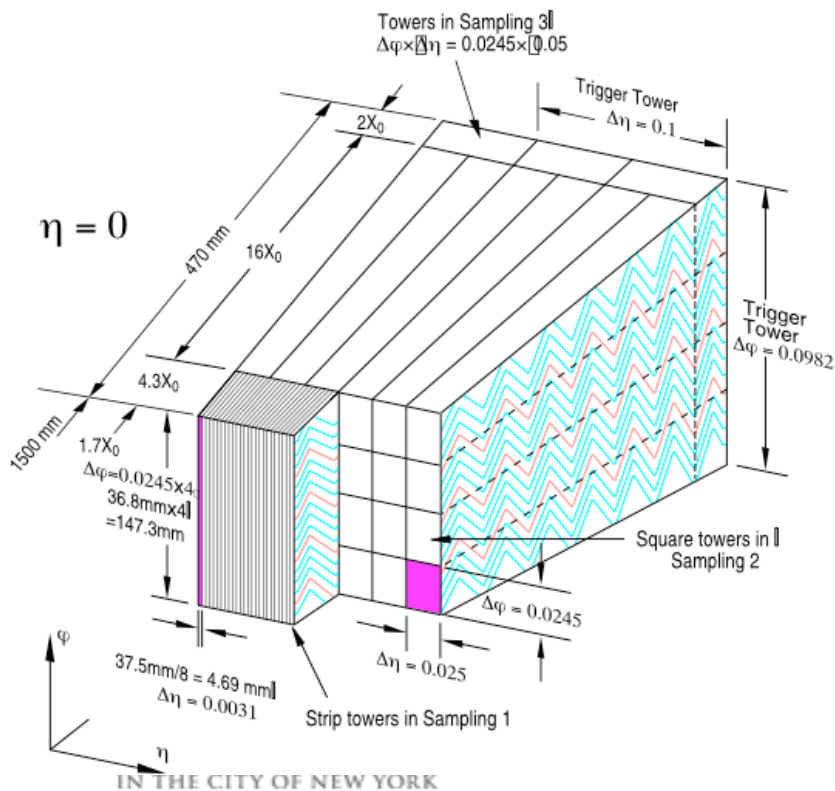

Nathan Grau

9/4/2006

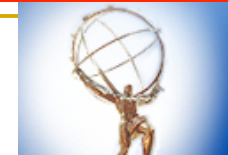

---

# Expectations for Jet Production/Modification at the LHC



# Jets in p+p Collisions

- Vacuum radiation is important!

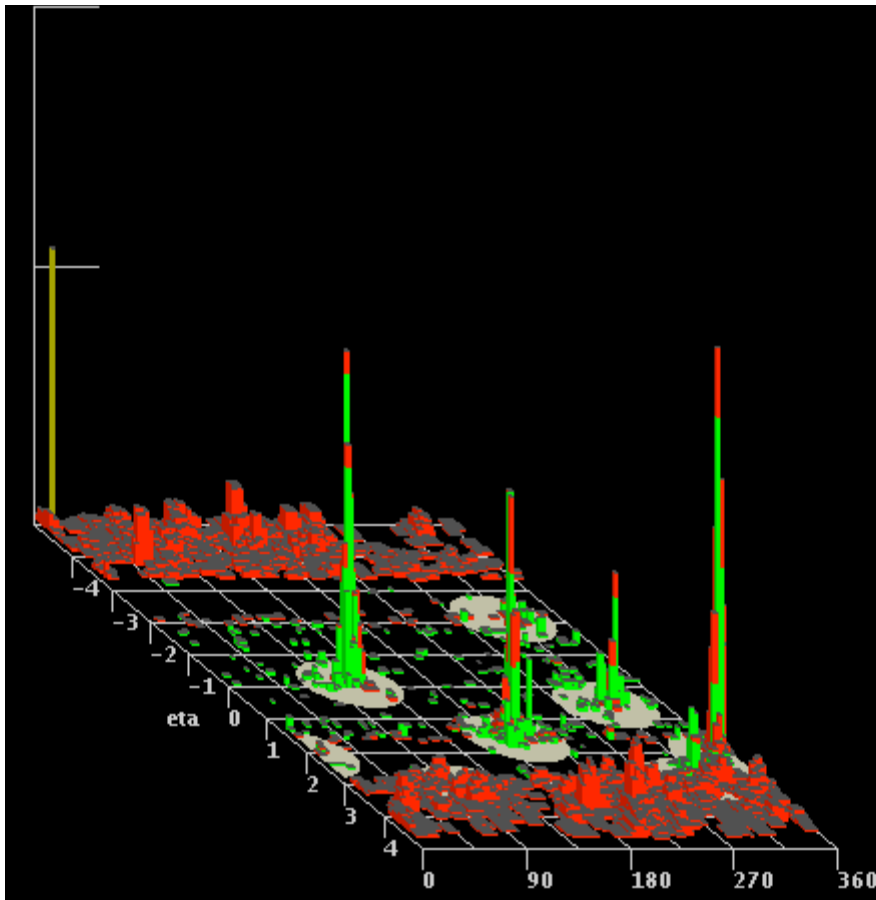

Simulated pythia event with hard scattering from 140-280 GeV

Just considered PDFs

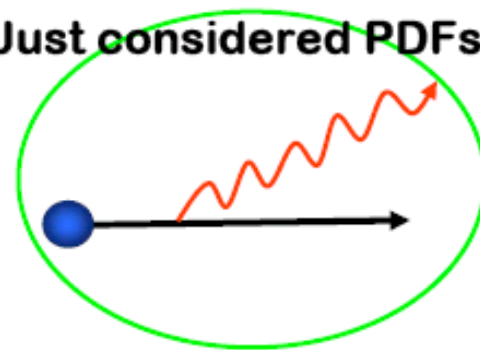

# Predictions for LHC: Gluon Radiation

- The distribution of radiated gluons related to  $\hat{q}L$
- Hard radiation in the tail  $\rightarrow$  **subjets**
- Requires a precise measure of the jet direction

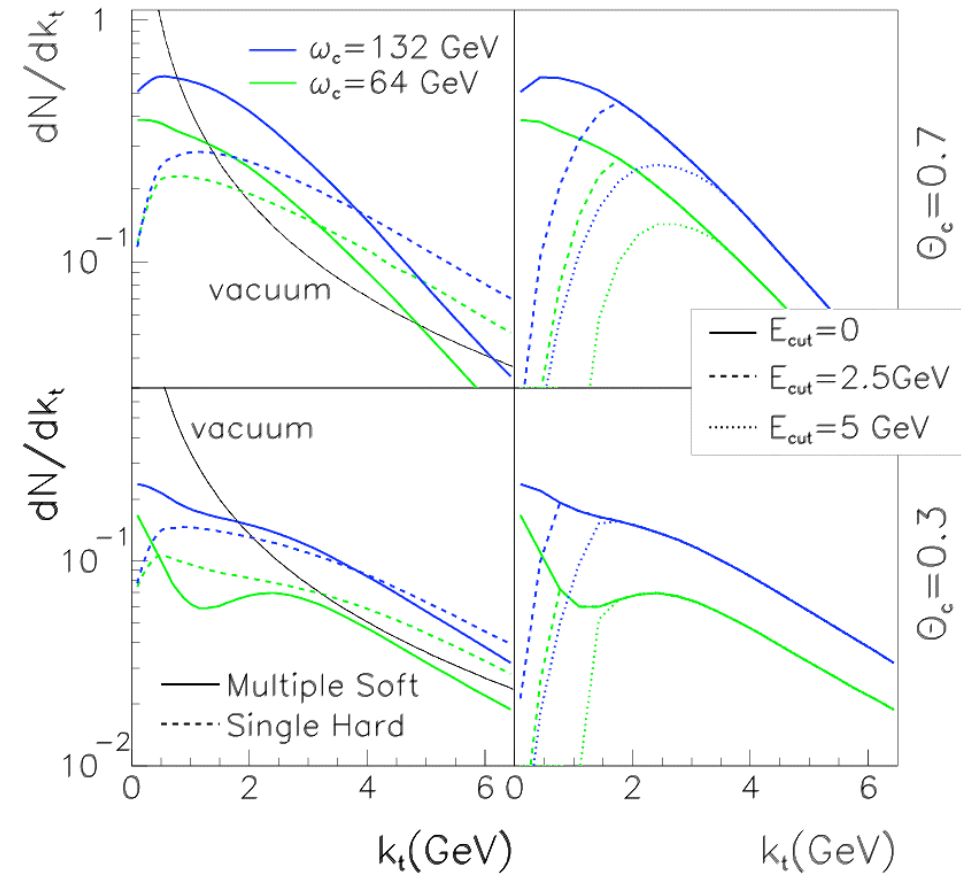

# Predictions for LHC: Fragmentation

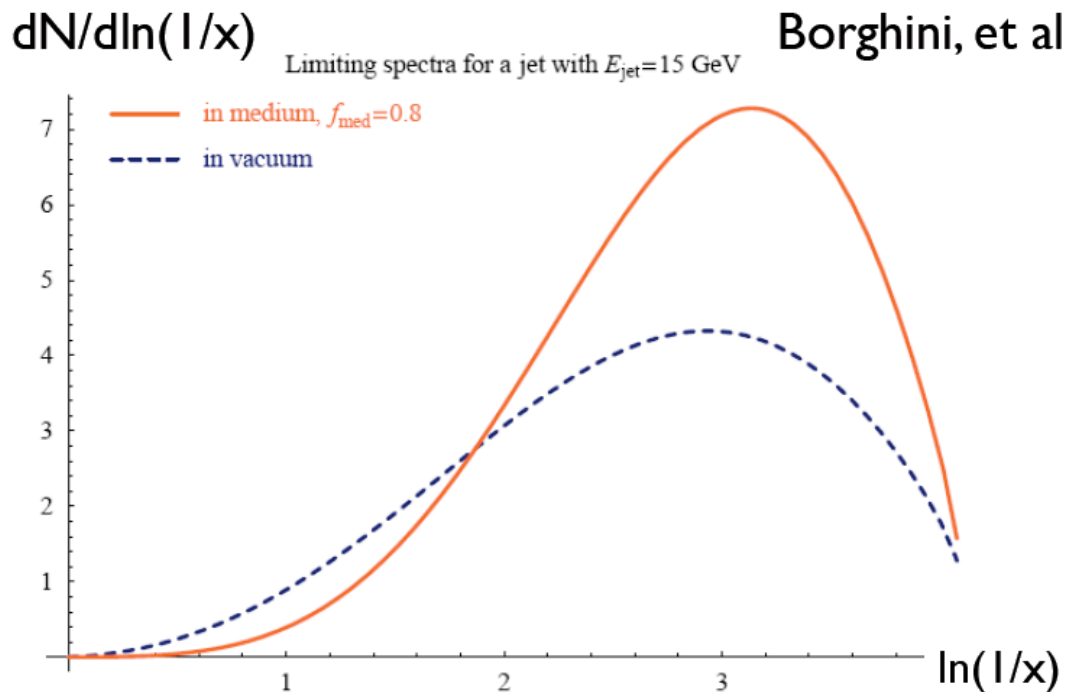

- Measurements of jet fragmentation functions will be possible
- Test of energy loss via the modification of these wrt p+p



---

# Capabilities of Jet Measurements with the ATLAS Detector



# Overcoming the Background in Pb+Pb

- HIJING predicts  $\sim 10$  GeV of energy per  $0.1 \times 0.1$  tower in central events
- Such a background must be removed prior to jet reconstruction

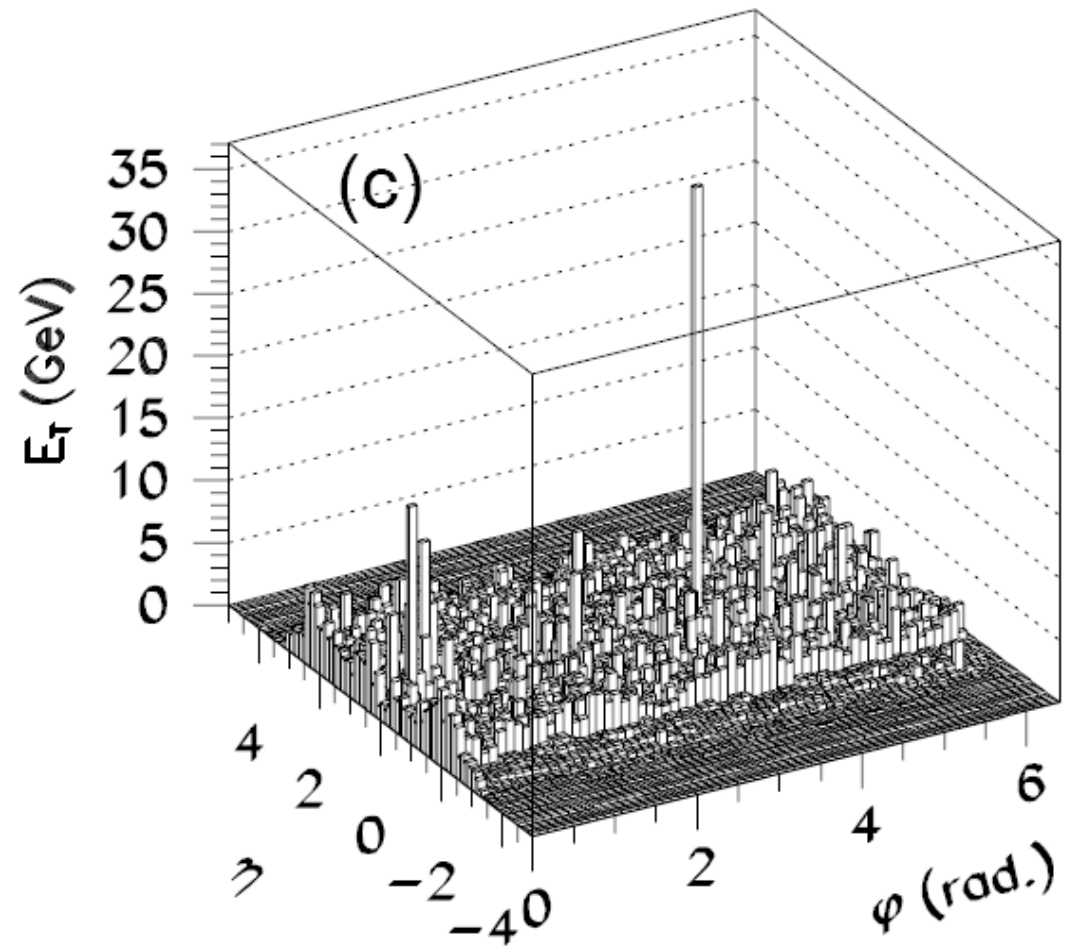

# Initial Studies: Background Subtraction

- Determination of the background was done segment-by-segment
  - Average over  $\phi$  as a function of  $\eta$
  - Exclude of regions of near jet seeds
- Subtract average energy from all towers segment-by-segment
- Run the p+p jet finding algorithm



# Background Subtraction Results

- PYTHIA embedded in HIJING w/  $\sqrt{Q^2} = 55$  GeV

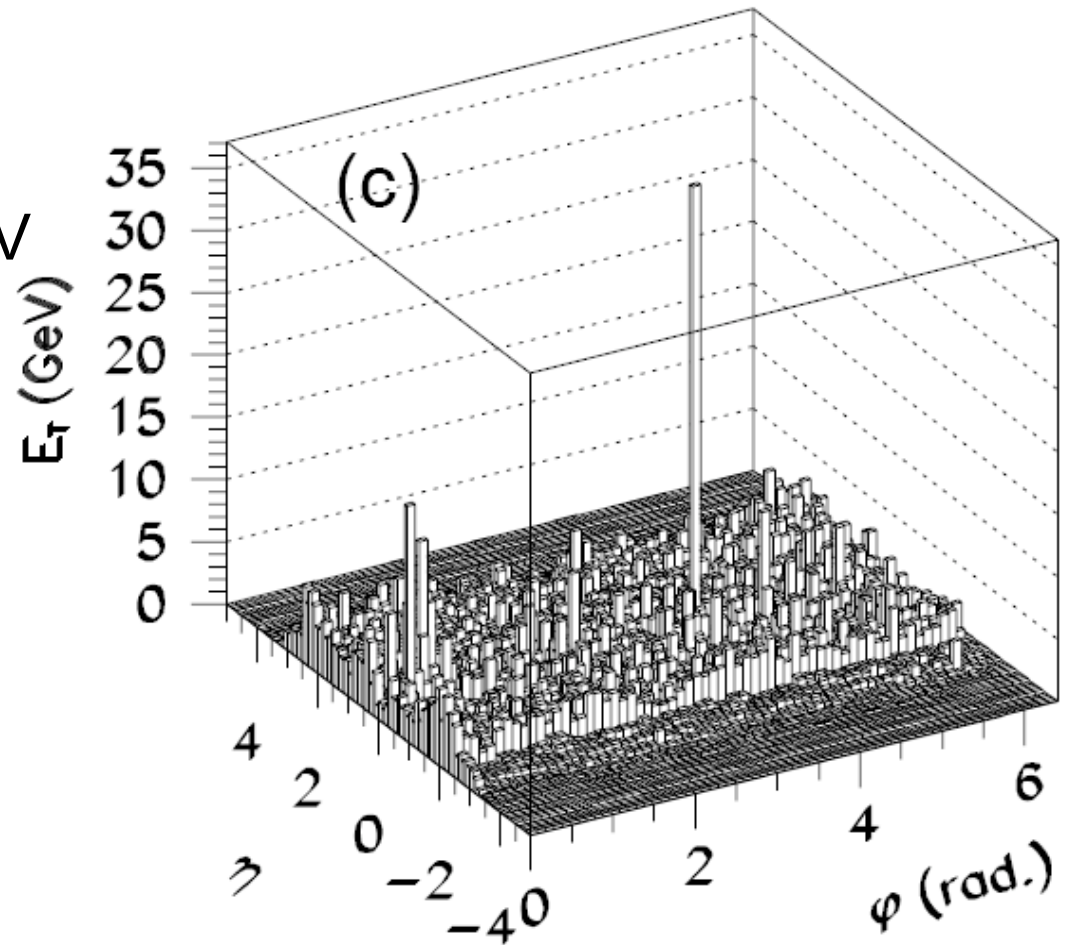

# Background Subtraction Results

- PYTHIA embedded in HIJING w/  $\sqrt{Q^2} = 55$  GeV
- After background subtraction

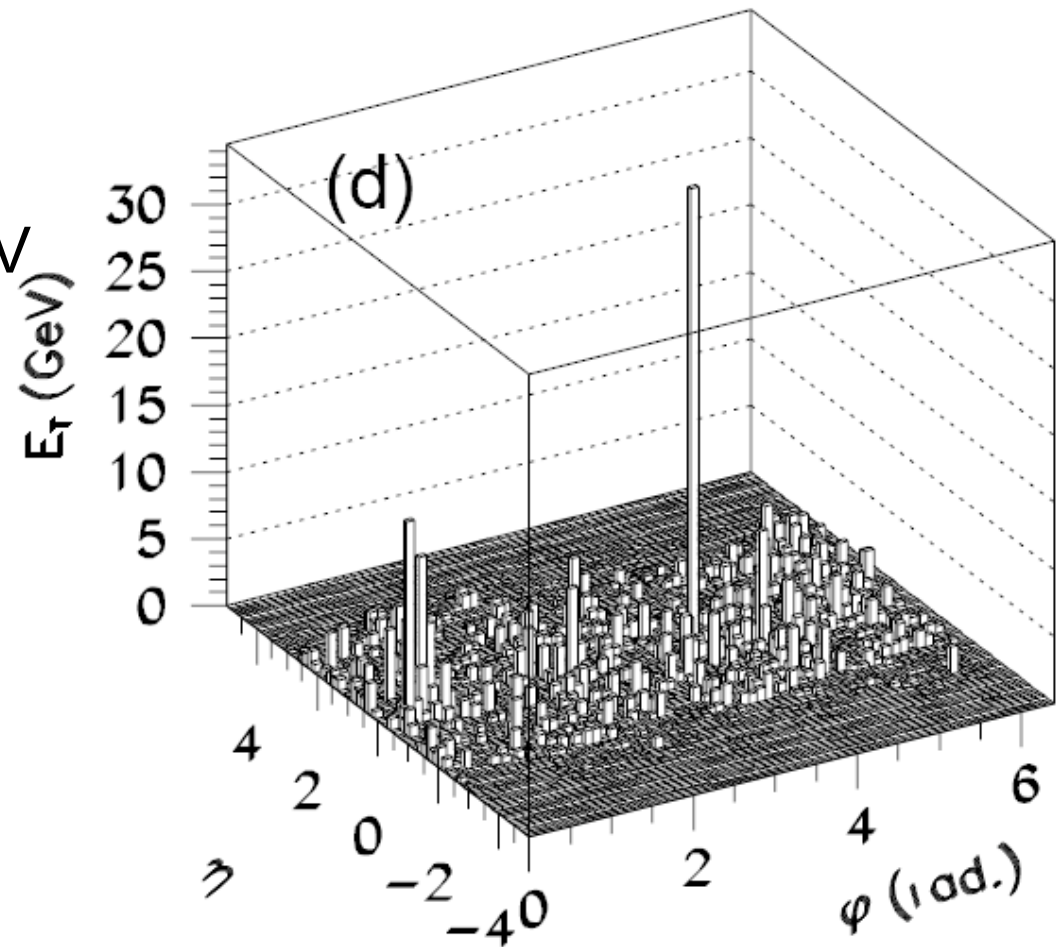

# Background Subtraction Results

- PYTHIA embedded in HIJING w/  $\sqrt{Q^2} = 55$  GeV
- After background subtraction
- Reconstructed Jets

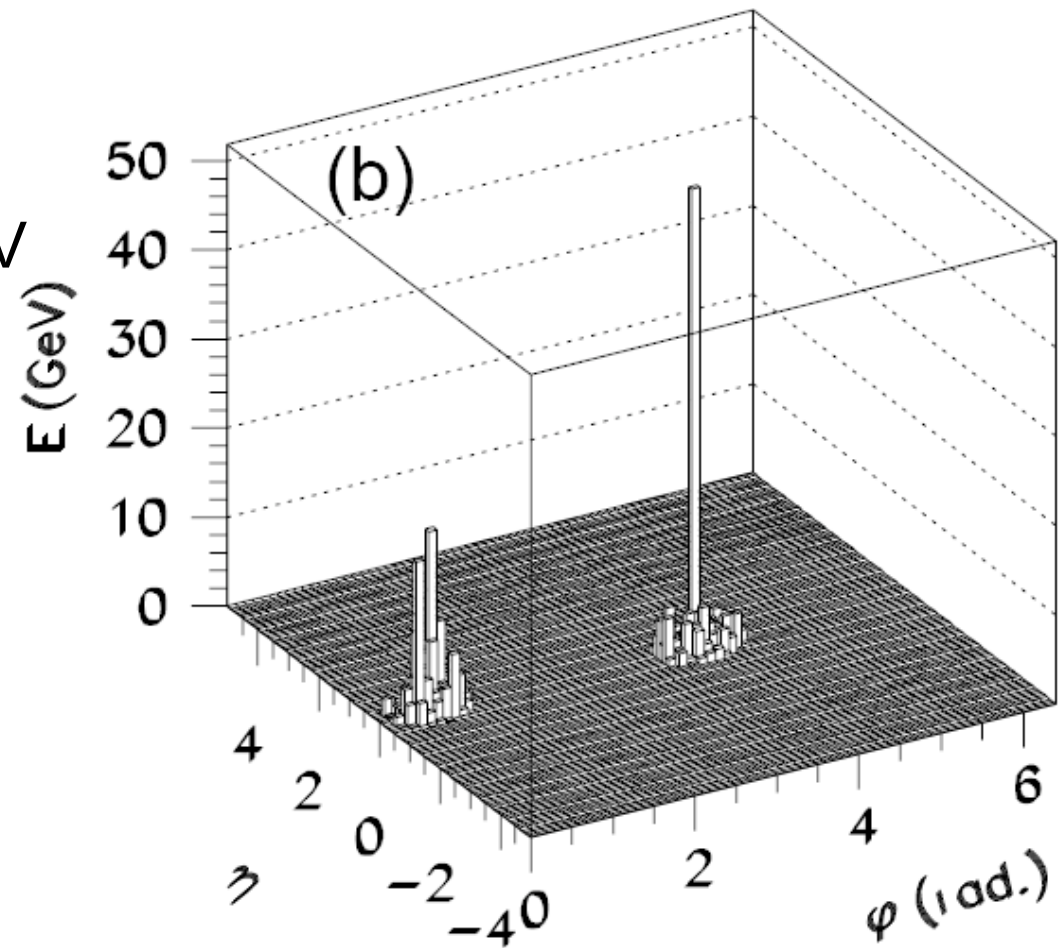

# Initial Jet Studies: Efficiency

- Comparing the reconstructed PYTHIA jets with the embedded reconstructed jets one obtains the efficiency

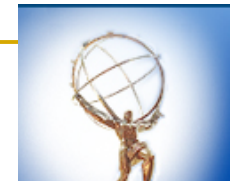
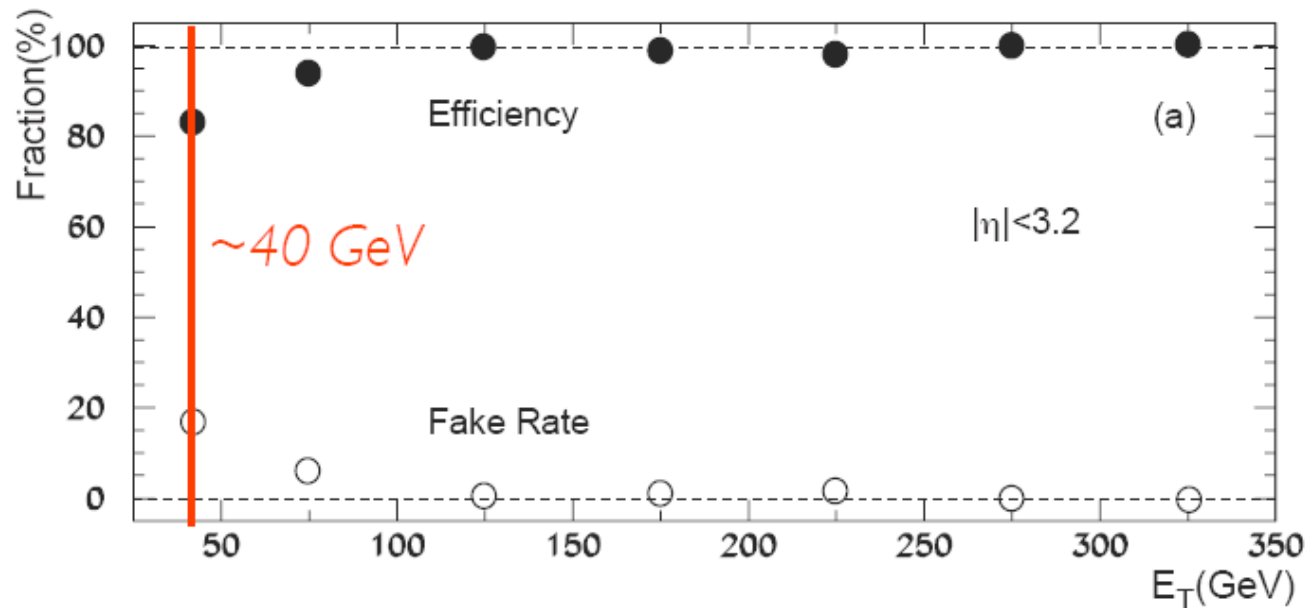

# Initial Jet Studies: Energy Resolution

- Energy calibration is important for detailed energy loss studies, i.e. catching the whole jet
- Jet calibrations may change due to background subtraction technique

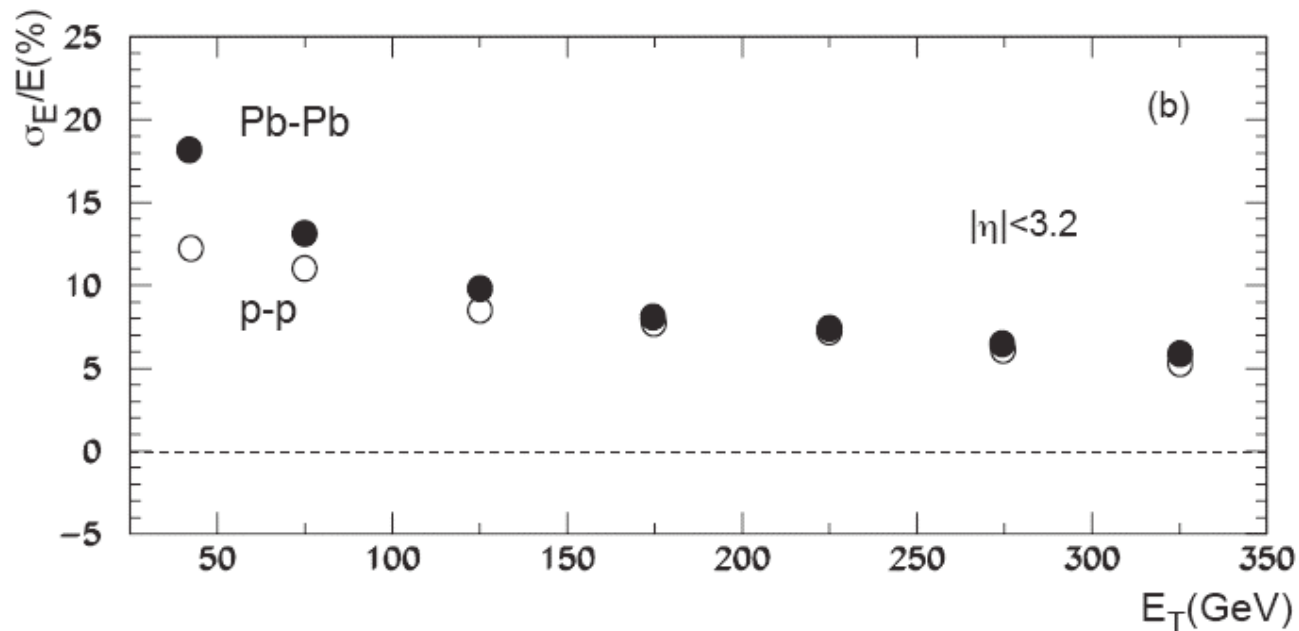

# Initial Jet Studies: Position Resolution

- Position resolution of the jet is important for sub-jet studies (hard gluon radiation) and  $j_T$  studies (soft gluon radiation)
- Resulting resolutions are  $\sim 2x$  larger than p+p

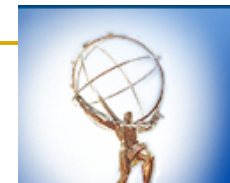
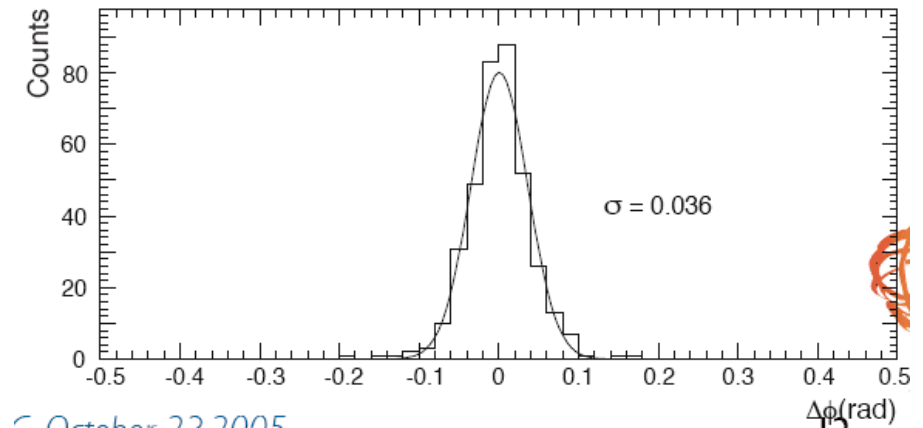
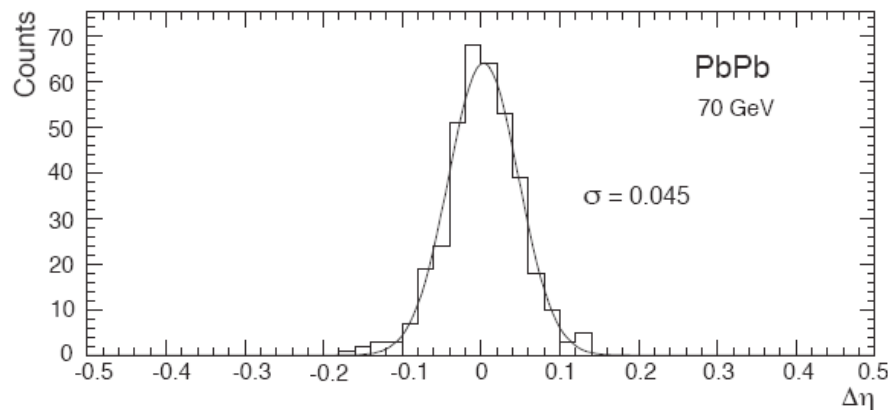

---

# Recent Work on Jet Reconstruction in HI Collisions



# Overview of Recent Work

- Added people over the last 8 months
- Worked out major hurdles in using official ATLAS software which underwent major changes since the LOI
  - Generation of simulated HI events, PYTHIA events, single particle events
  - Full Geant4 simulation of HI events
  - Embedding signals into the HI events
  - Reconstruction of HI events
- Considerable integration into ATLAS
  - Initiated the “Minimum Bias” physics: sub-group of Standard Model Group.
  - Optimizing tracking for HI environment
  - Jet background subtraction



# Update on Tracking (I)

- First look at optimization of the tracking
- 70% efficiency in central, 80% efficiency in peripheral
- Large fake rate in central, more work ongoing

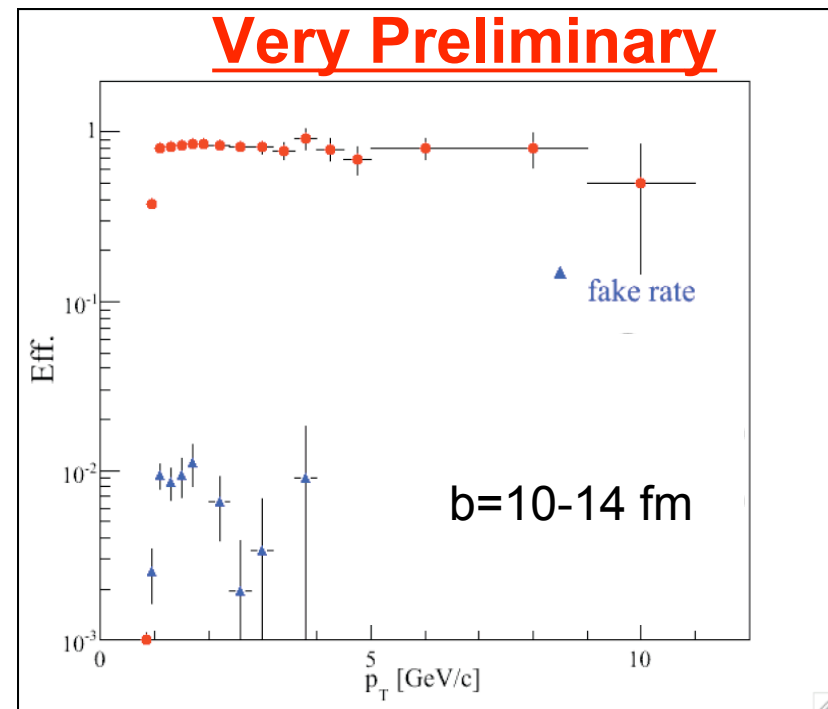
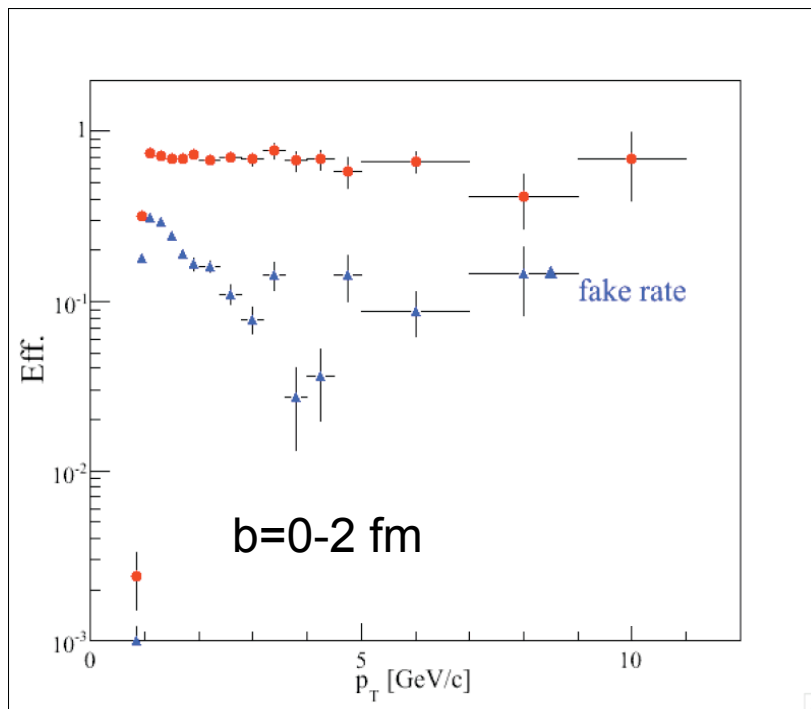

# Update on Tracking (II)

- Work by HI and HE people to track down to  $p_T \sim 0.5$  GeV

Very Preliminary

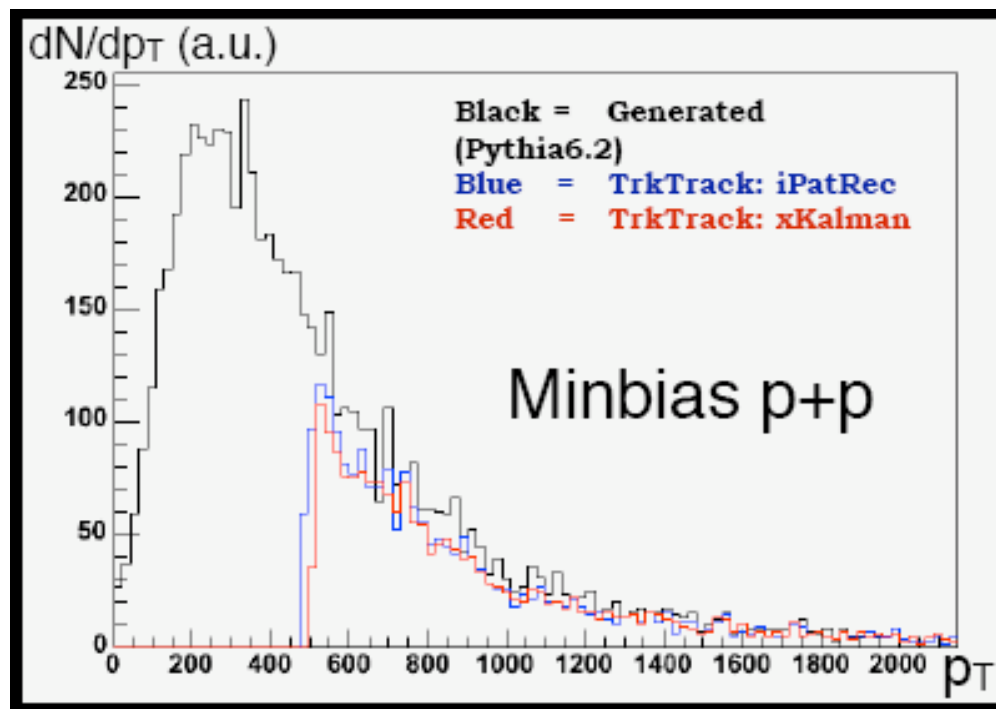

# Update on Jet Background Subtraction

- Before towers are made from the Calorimeter cells, apply some background subtraction method
  - We are writing and testing several methods at the moment
- After the cell background subtraction apply the p+p tower building and jet finding algorithms
  - Use the same weighting and energy corrections applied to the p+p data



# Results for Background Subtraction

- Apply the same background subtraction as described previously
- Use a Cone R=0.4 algorithm
- RMS of energy reconstructed within the cone

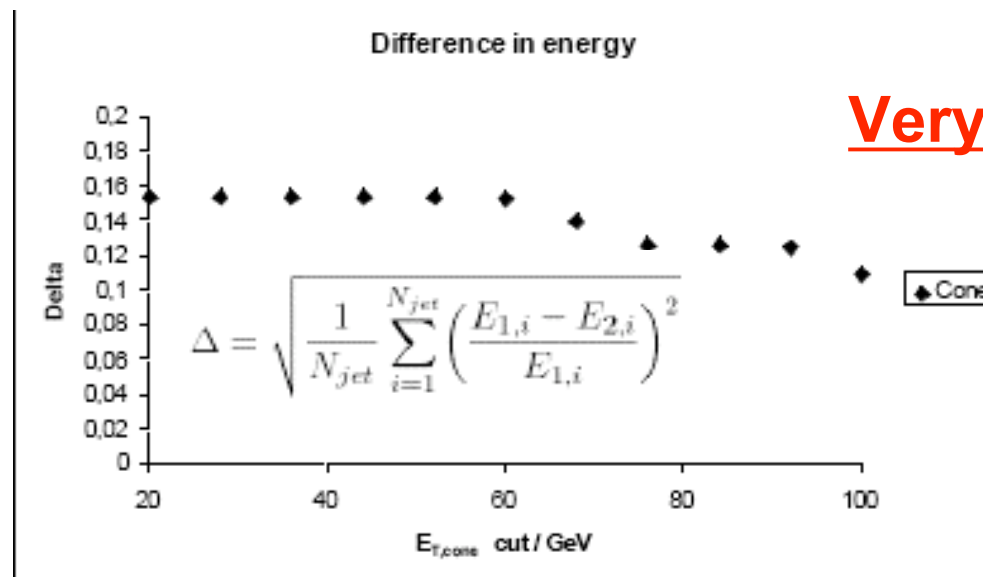

# Utilizing the Calorimeter Segmentaion

- Use longitudinal segmentation as a measurement of the background

**Very Preliminary**

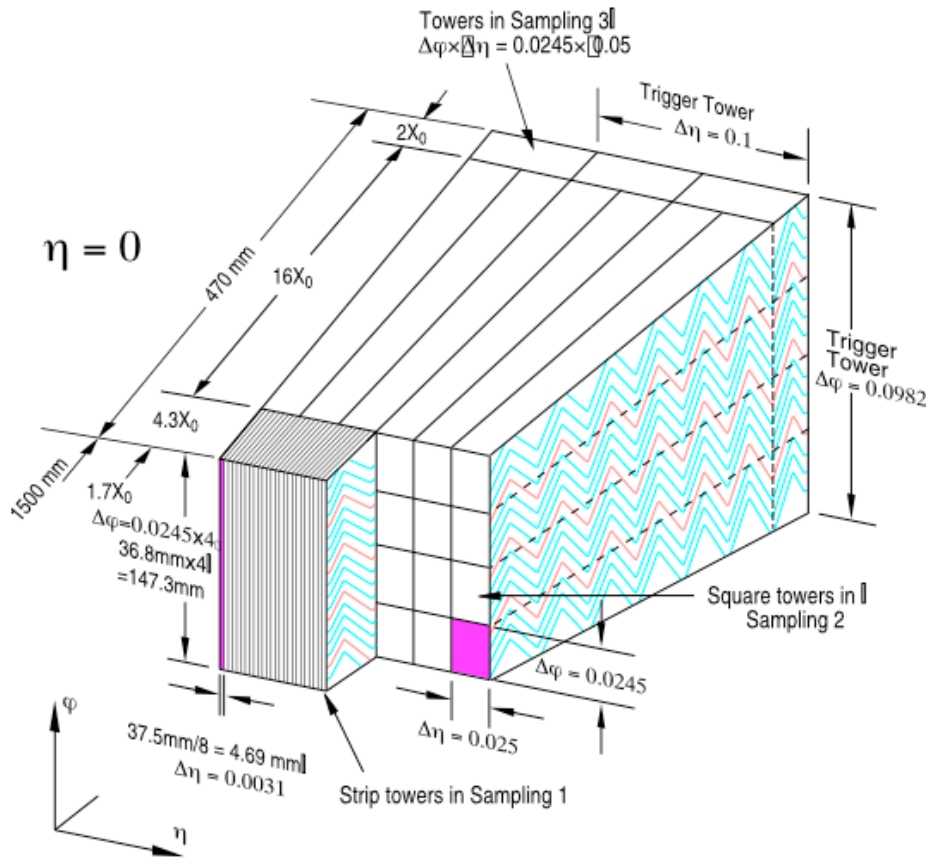

number of cells

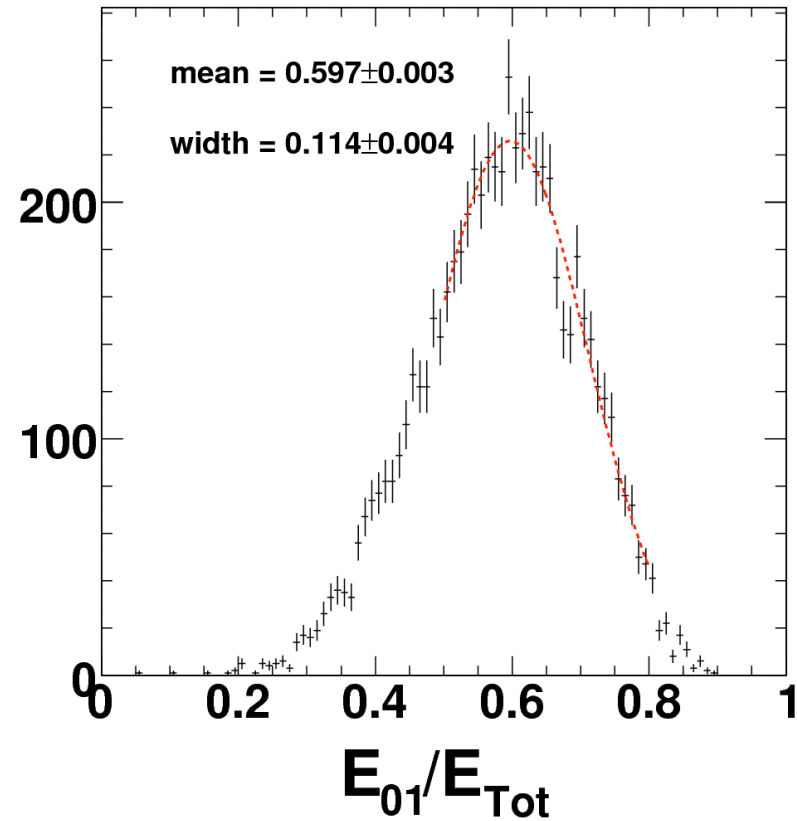

# Improvement of S/B

- Hijing+Pythia event looking at the 2<sup>nd</sup> and 3<sup>rd</sup> sampling layers of EMCal
- Increase in S/B by a factor of 2

$$E_{\text{Tot,bkg+jet}}/E_{\text{Tot,bkg}}$$

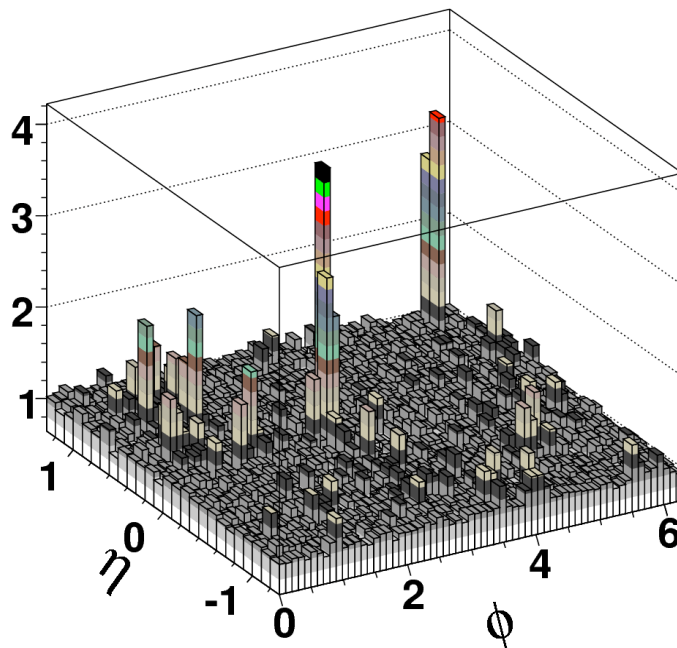

$$E_{23,\text{bkg+jet}}/E_{23,\text{bkg}}$$

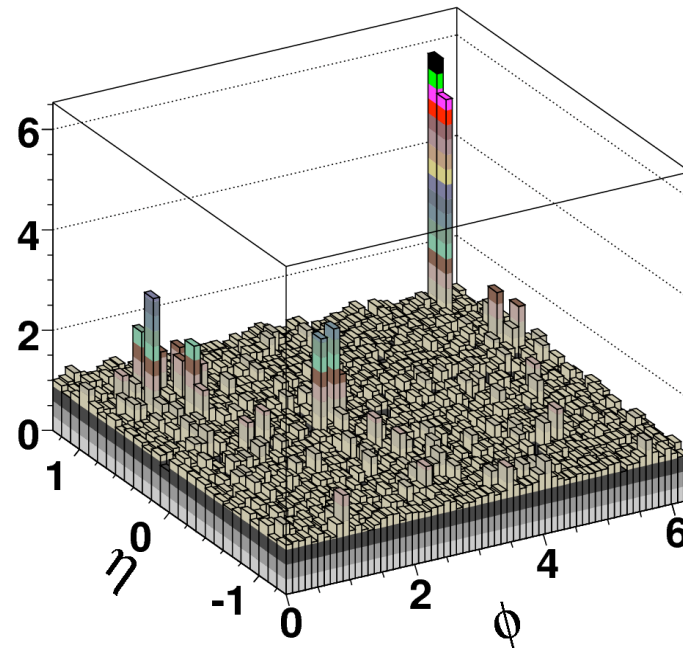

Very Preliminary



# More yet to do

- We have a flow afterburner to simulate flow
- We have incorporated the pyquen afterburner

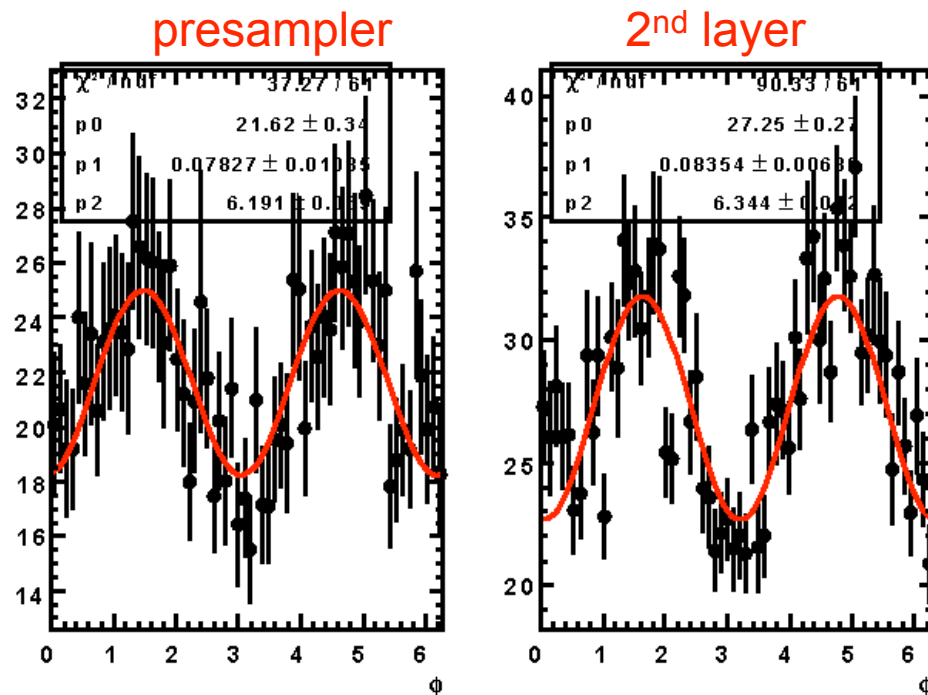

## Very Preliminary

- Pre-sampler and 2<sup>nd</sup> sampling layer f-distribution
- Generated RP = Fitted RP



---

# Beyond Pb+Pb Collisions at the LHC



# Necessity: p+Pb

- Follow success of RHIC by running p+Pb early since initial state gluon PDF not well constrained
  - CGC possibly accessible at mid-rapidity or at forward rapidity
    - Test by mono-jets
    - Test by  $\gamma$ -jet rates



# Necessity: running at $\sqrt{s} = 5.5 \text{ TeV}$

- Necessary to have a baseline at the same  $\sqrt{s}$
- Interpolation is not necessary: reduced systematics
- DGLAP breaks down at low- $x$  for PDFs and low- $z$  in the fragmentation function: reduced systematics
  - Example measuring the  $D(z)$  at 900 GeV and 14 TeV will not allow you to determine  $D(z)$  for  $z < 0.1$  at 5.5 TeV.



# Summary and Conclusions

- Effort ramping up on ATLAS HI with many new additions and with software stability
- Jet physics in HI clearly a major goal of the HI program at ATLAS
  - New understanding of energy loss in A+A
  - Tests/Confirmation of the CGC in p+p, p(d)+A, and A+A
- For such a program p+p and p+A running at 5.5 TeV is important

