

# The ATLAS Detector

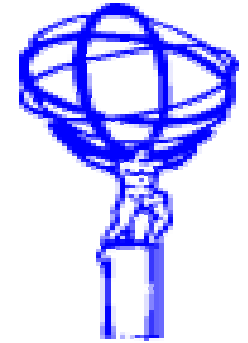

ATLAS

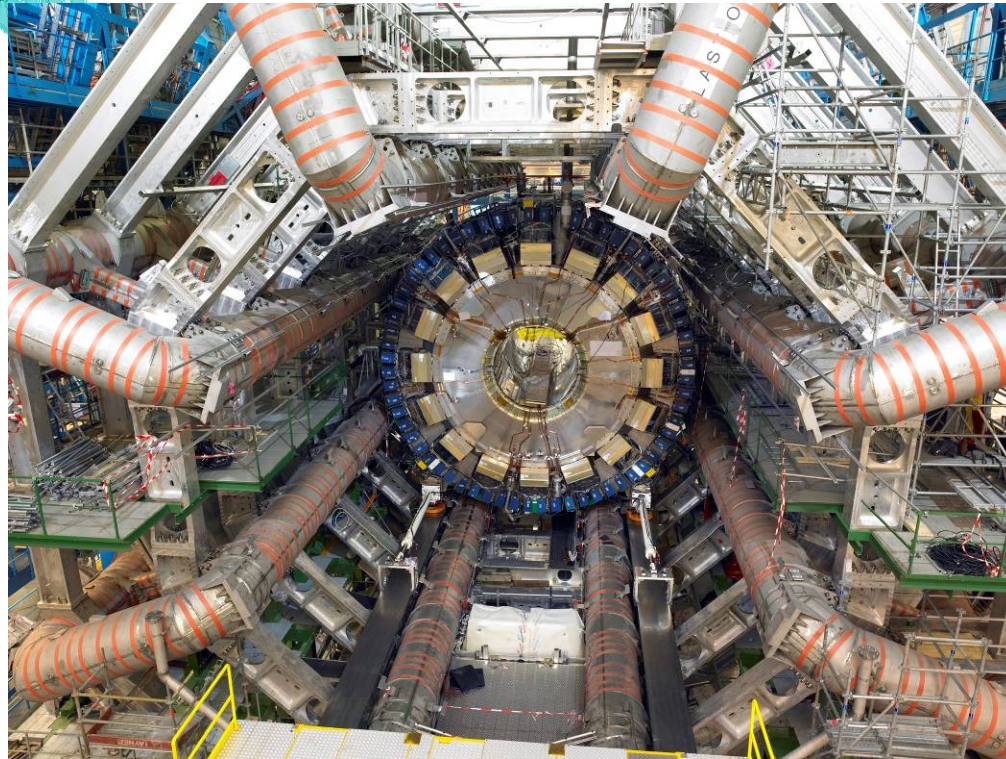

(see <http://atlas.web.cern.ch/Atlas/Welcome.html>)

# The Large Hadron Collider at CERN (LHC)

- 7+7 TeV pp collider
  - 25 ns bunch spacing
  - $\approx 20$  int./crossing
- at high luminosity
- $\Rightarrow \approx 800$  million pp collisions per second

## Example data sets

- $10 \text{ fb}^{-1}$  (one yr. at low lumi.)
  - $6 \times 10^{12}$  b-bbar
  - $2 \times 10^9$  W
  - $5 \times 10^8$  Z
  - $8 \times 10^6$  ttbar
  - $2 \times 10^5$  H ( $m_H=150$ )
- Scheduled to begin running in 2007

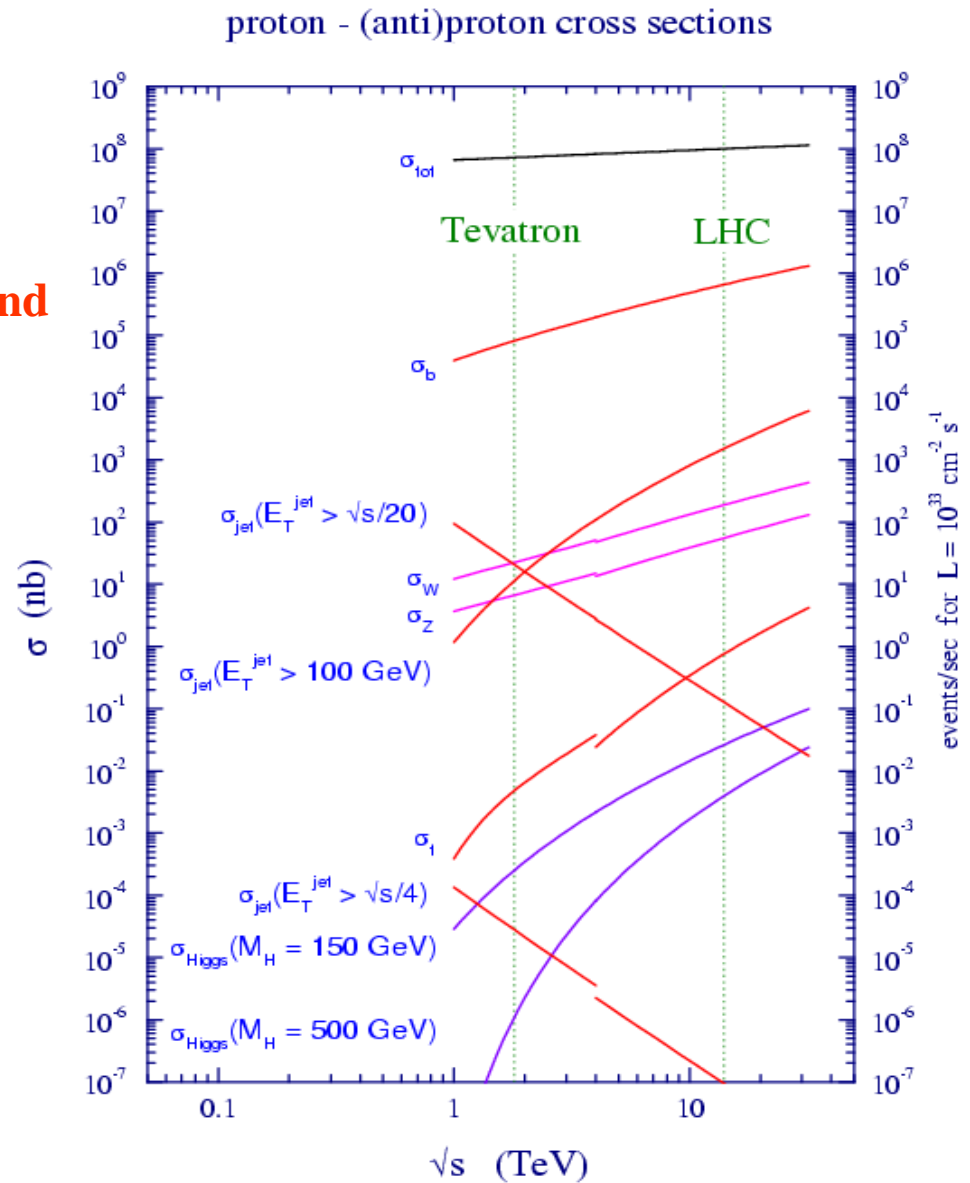

# Particle Detection Principles

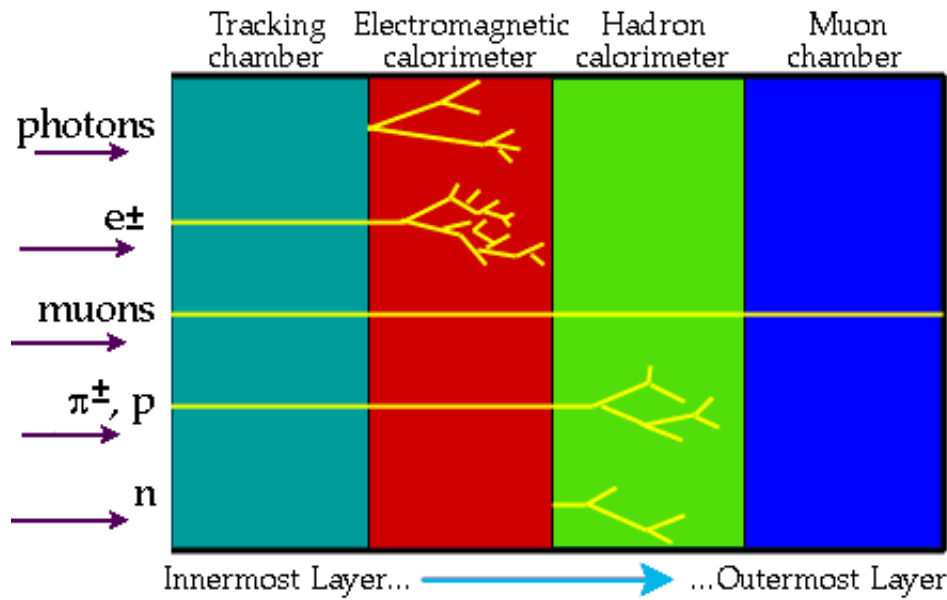

A detector cross-section, showing particle paths

- Beam Pipe (center)
- Tracking Chamber
- Magnet Coil
- E-M Calorimeter
- Hadron Calorimeter
- Magnetized Iron
- Muon Chambers

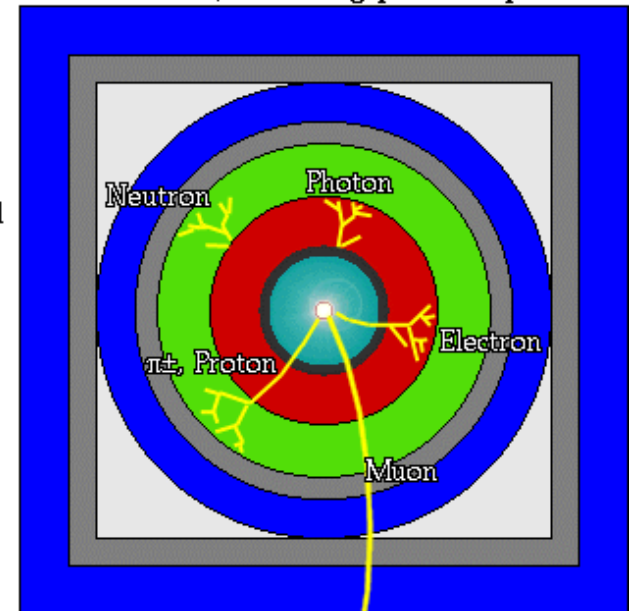

# The ATLAS Detector

- Overall length = 42 m, diameter = 22 m, weight = 7000 tons

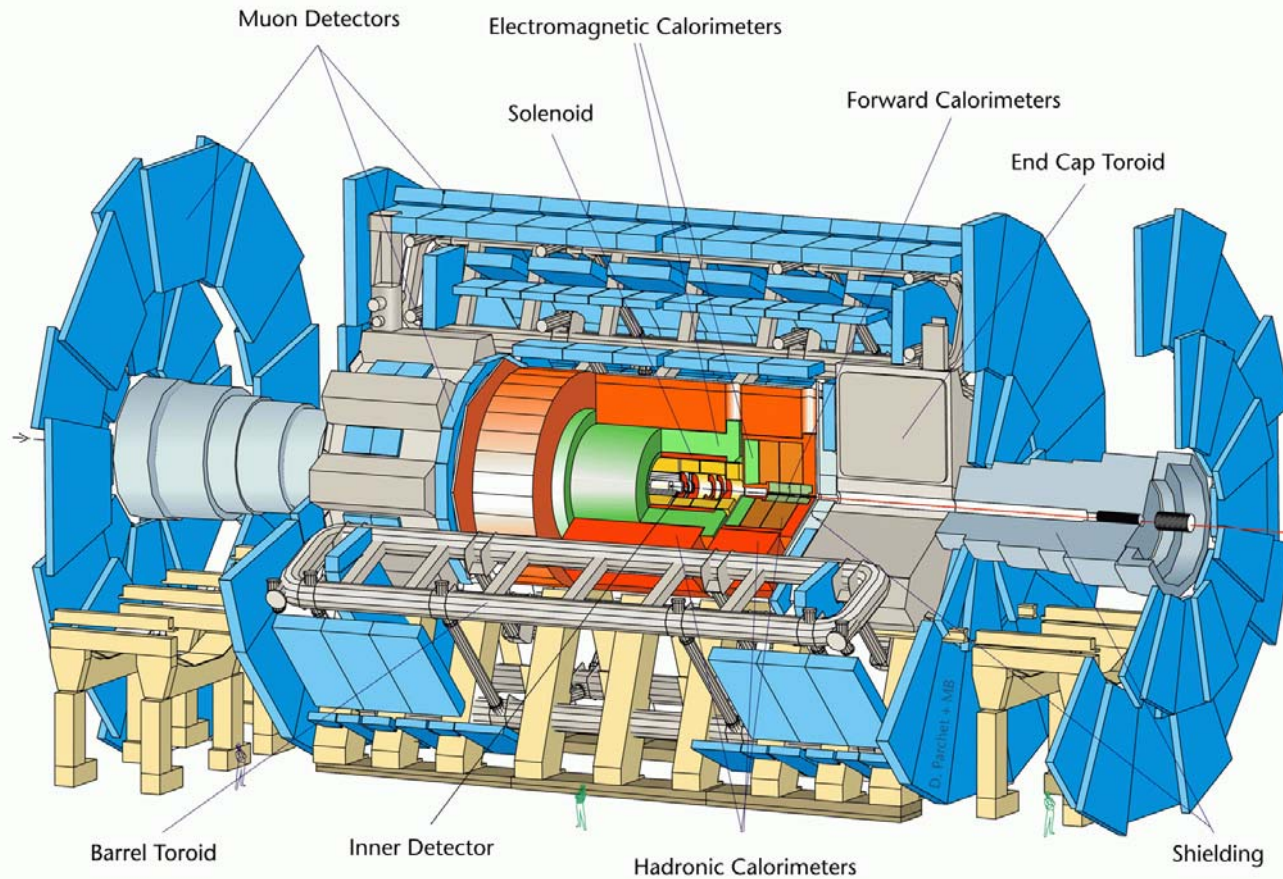

- Components under construction in over 35 countries around the world



# ATLAS Inner Detector

- $r = 1.15$  m, length = 7 m (  $|\eta| < 2.5$  ), 2 T solenoidal magnetic field

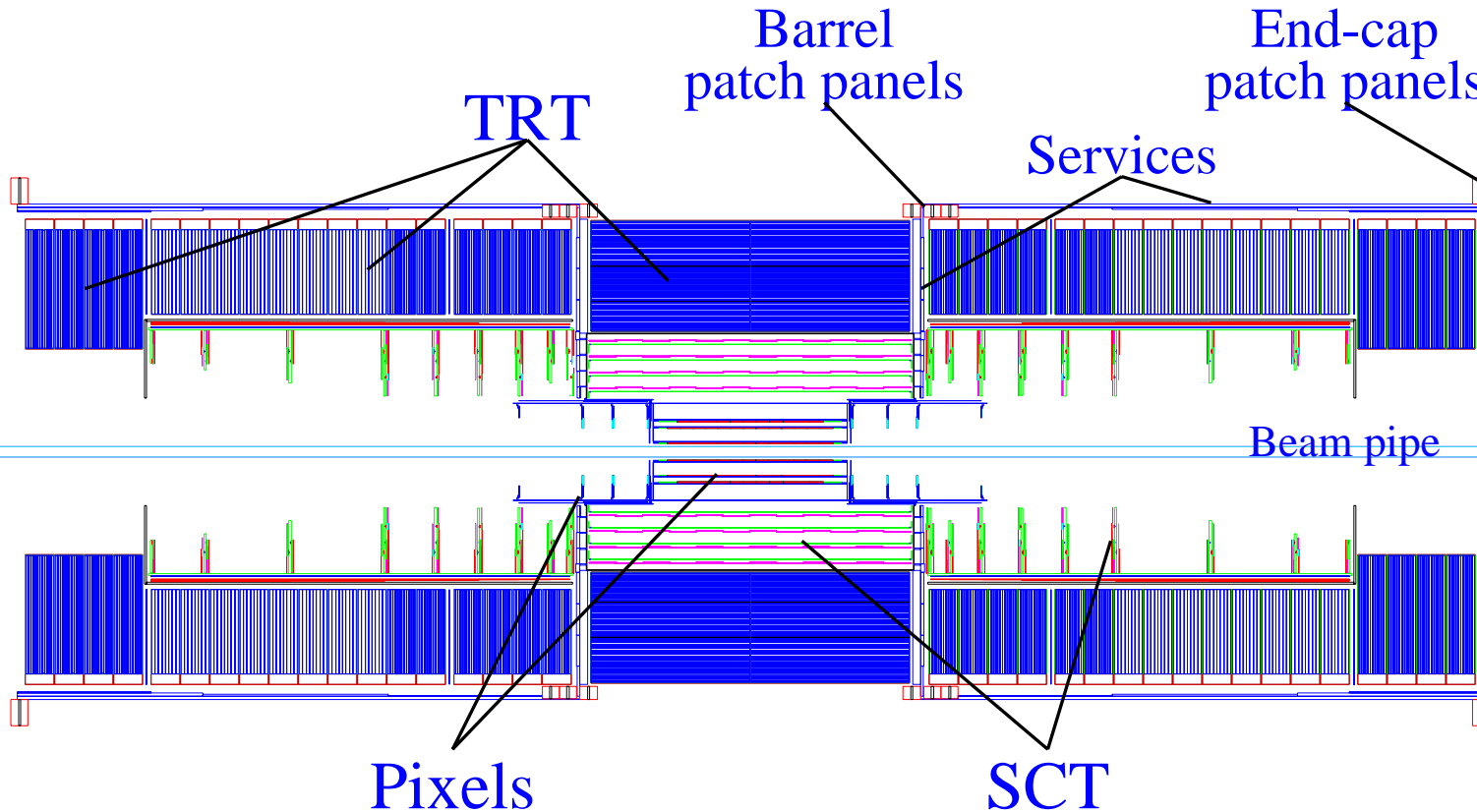

- 3 layers ( $r = 4, 11, 14$  cm) of  $50 \mu\text{m} \times 300 \mu\text{m}$  Si pixels (140E6 in total)
- 4 layers of  $80 \mu\text{m} \times 12.8$  cm Si strips (6.2E6 in total)
- 36 layers of 4 mm dia.  $\times$  1.5 m (max) straws (420k in total)

# ATLAS Inner Detector

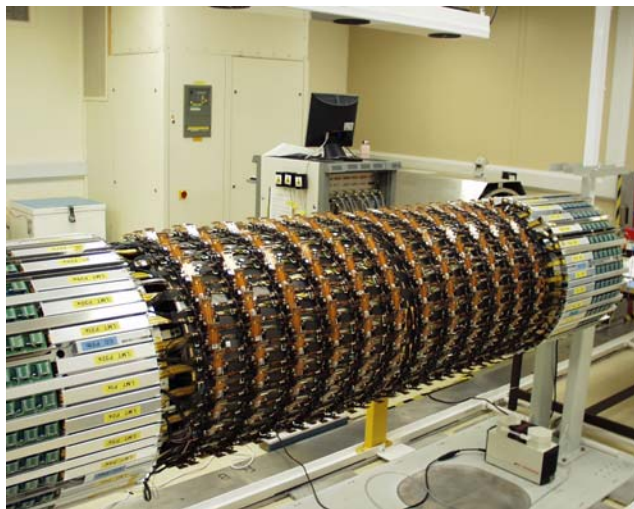

**Barrel SCT**

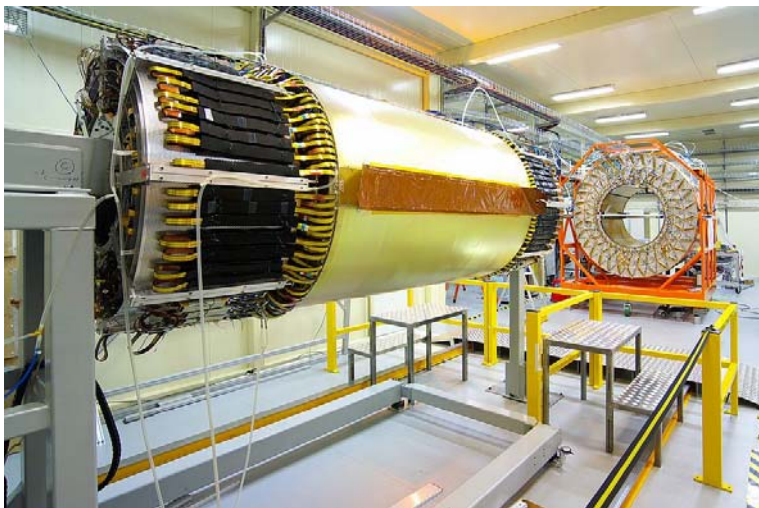

**Integration of SCT into Barrel TRT**

# ATLAS Inner Detector Performance

ATLAS Barrel Inner Detector

$H \rightarrow b\bar{b}$

Low luminosity

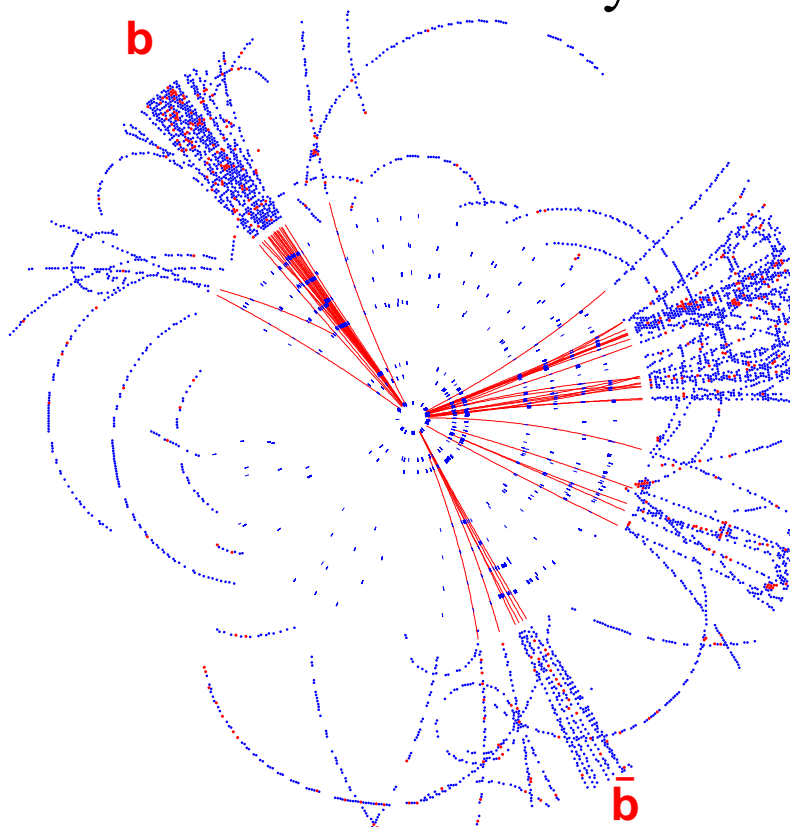

ATLAS Barrel Inner Detector

$H \rightarrow b\bar{b}$

Design luminosity

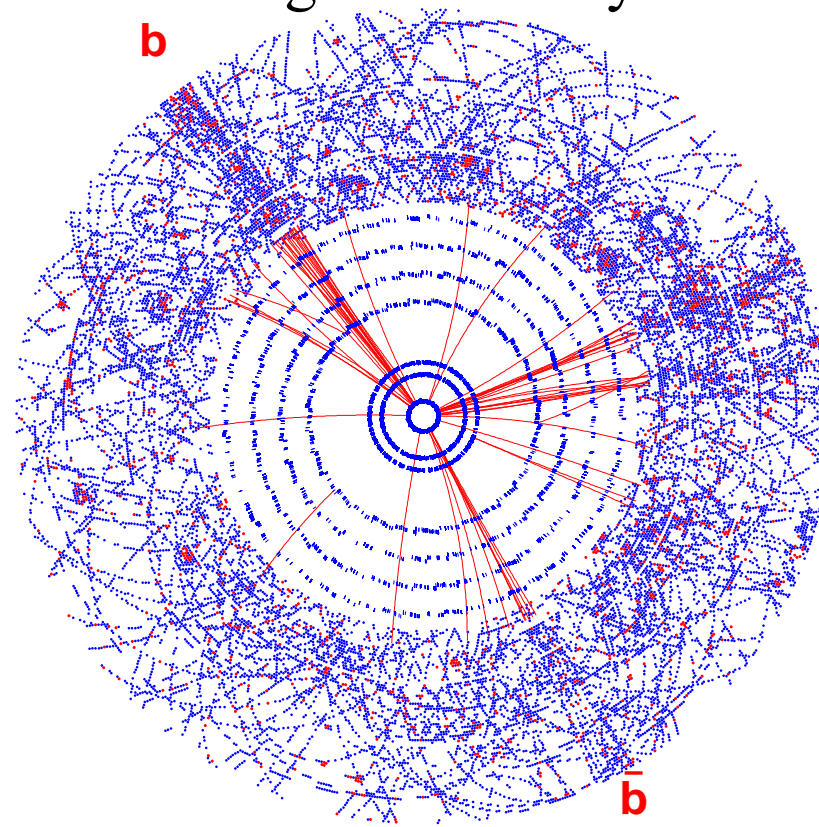

# ATLAS Inner Detector Performance (cont'd)

---

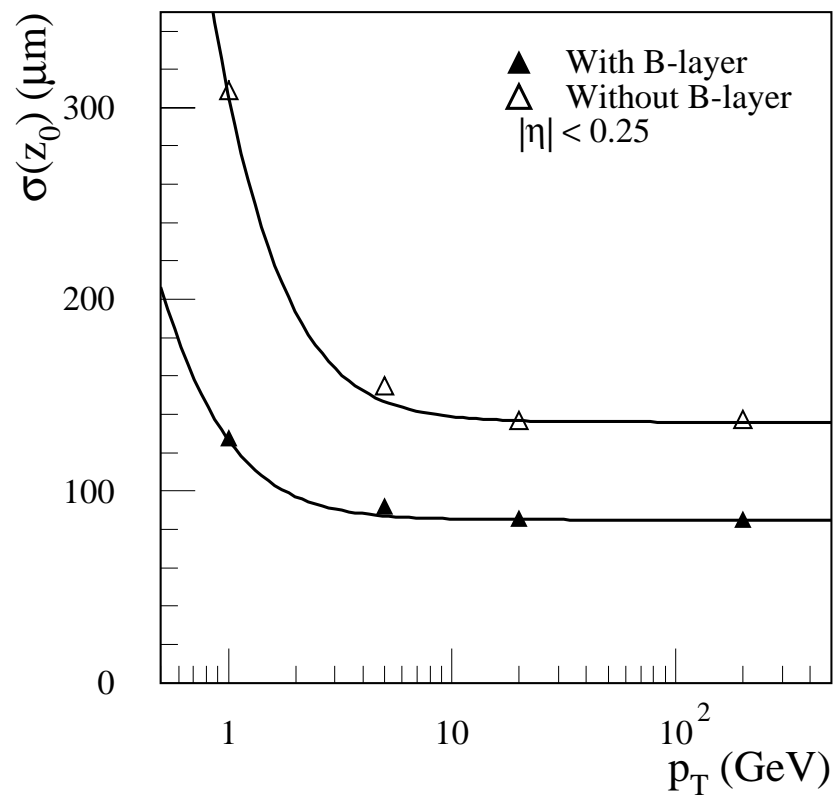
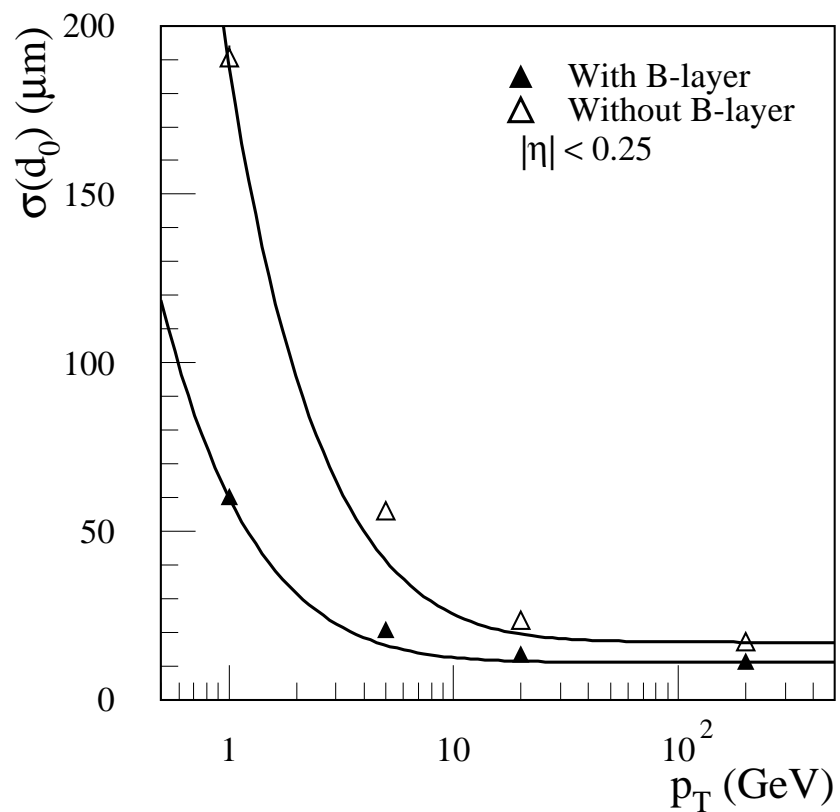

# ATLAS Calorimeters

---

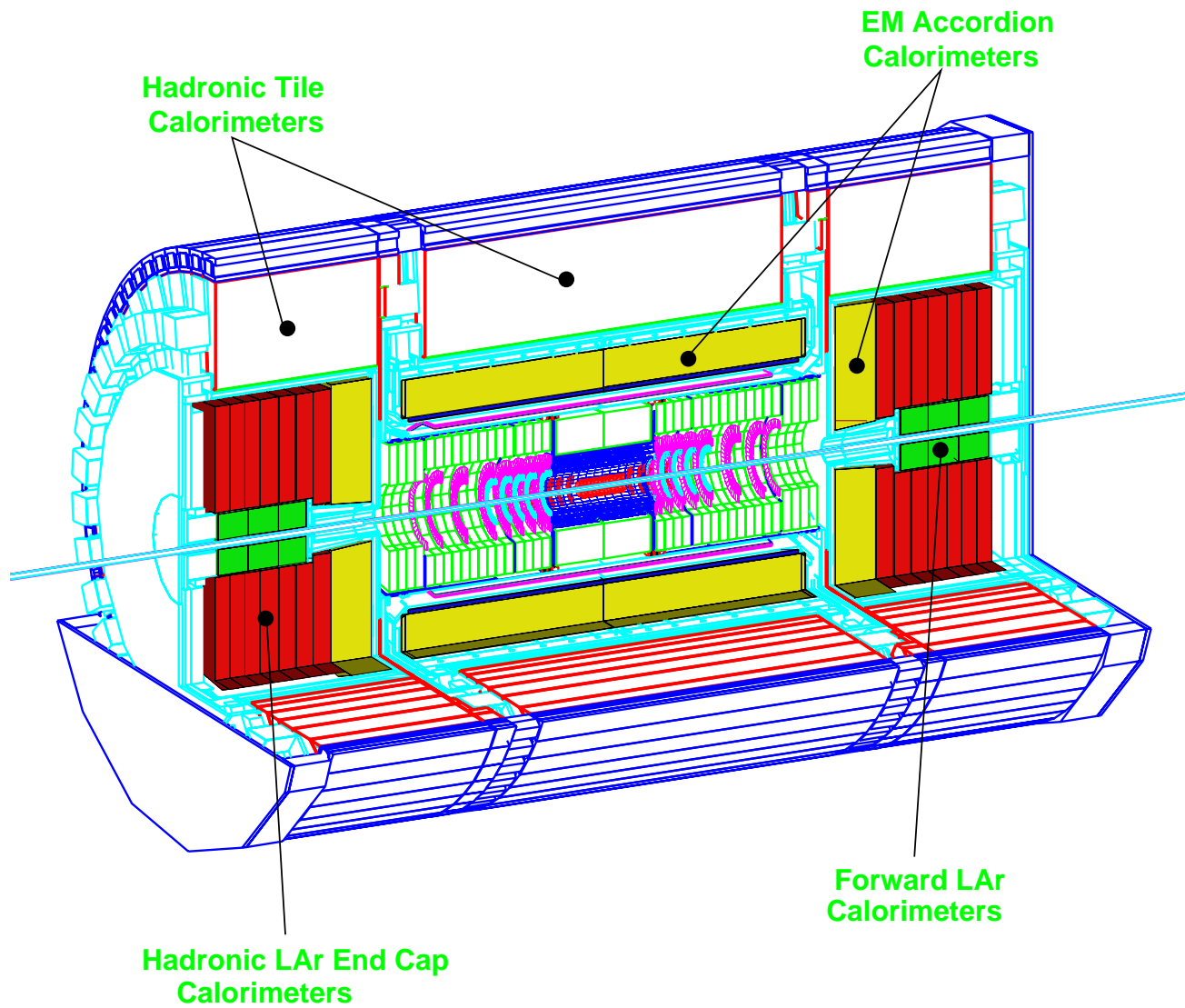

# The ATLAS Liquid Argon Electromagnetic Calorimeter

$$\frac{\sigma(E)}{E} \approx \frac{10\%}{\sqrt{E}} \oplus 0.7\%$$

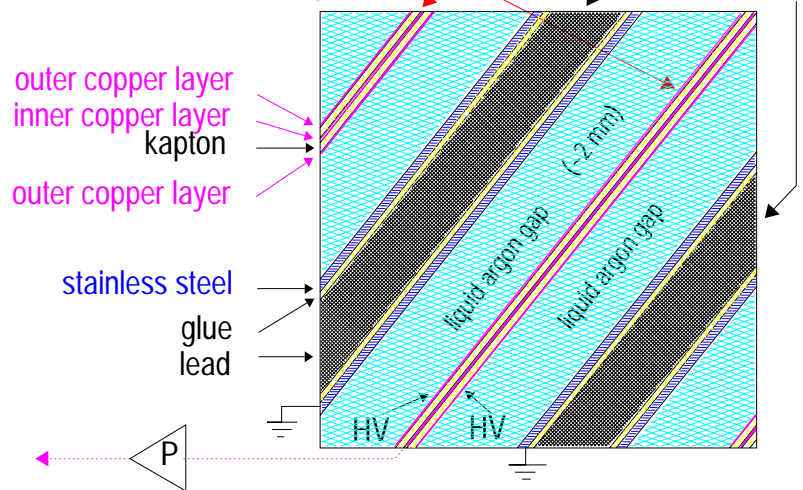
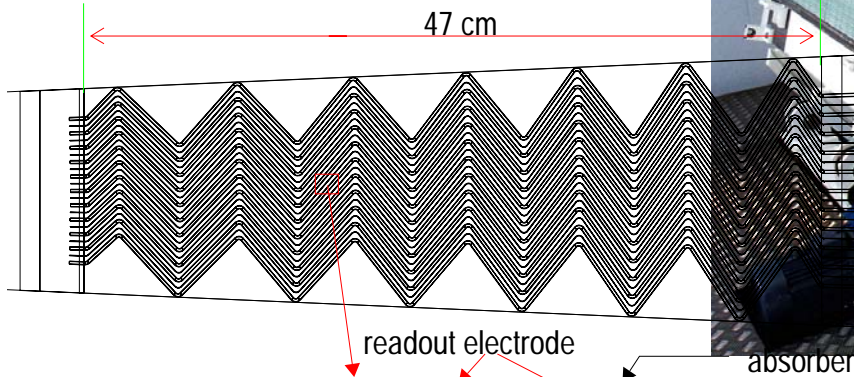
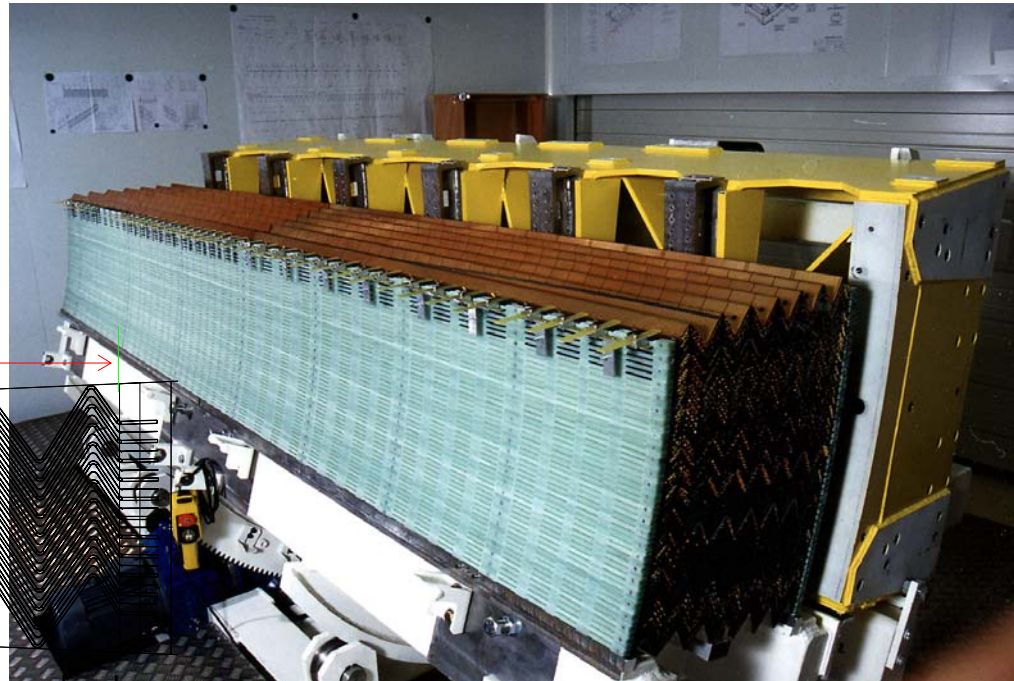

# The ATLAS Liquid Argon Calorimeter

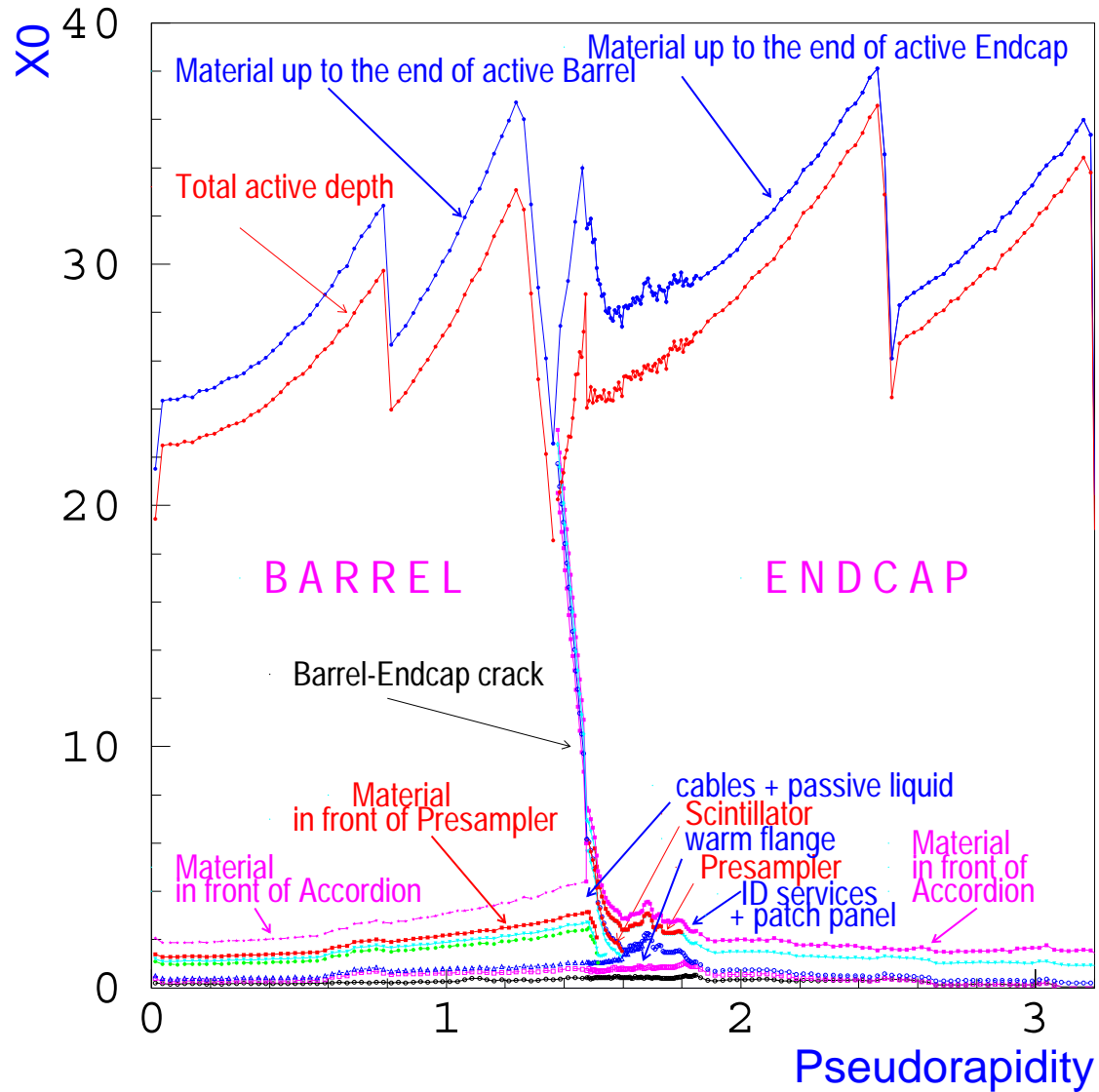

# The ATLAS LAr Barrel Wheel Assembly

---

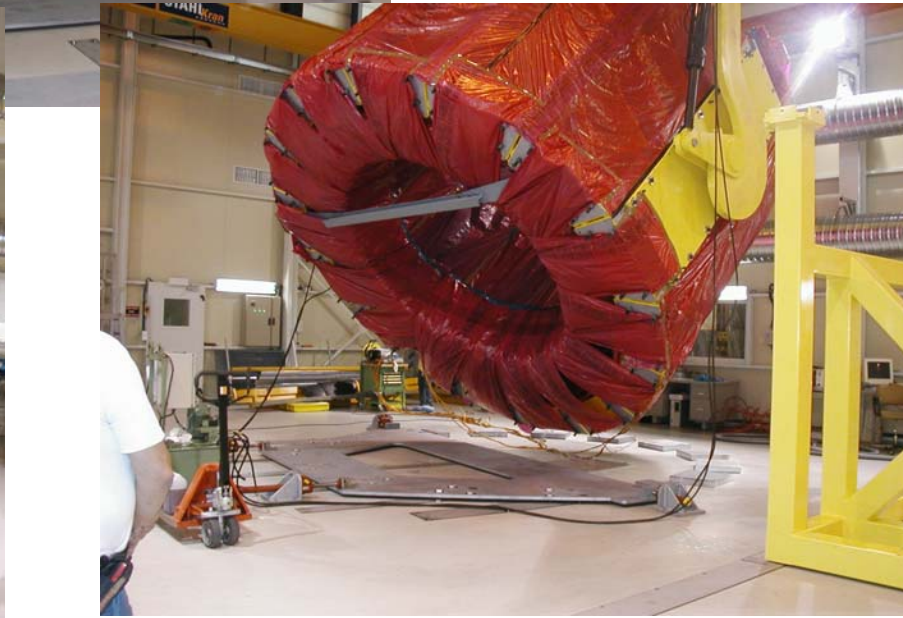
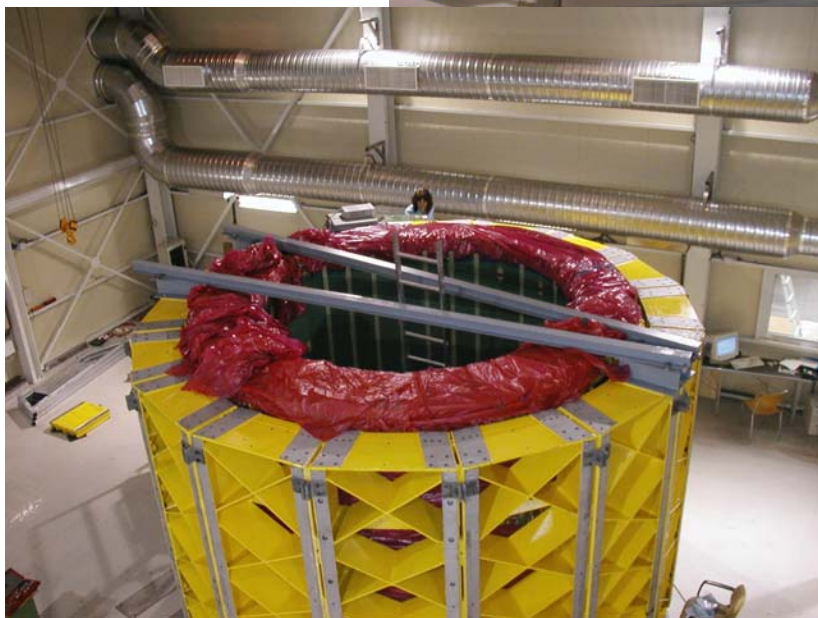

# The ATLAS Barrel Cryostat and Superconducting Solenoid

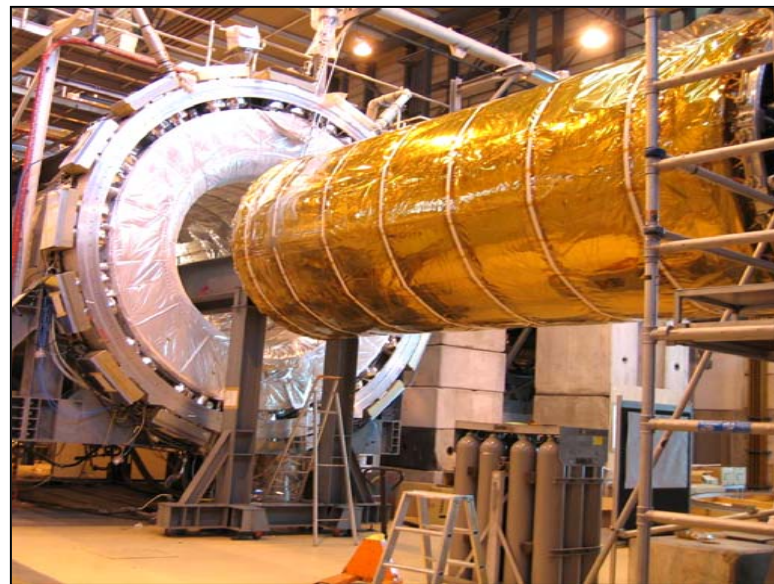
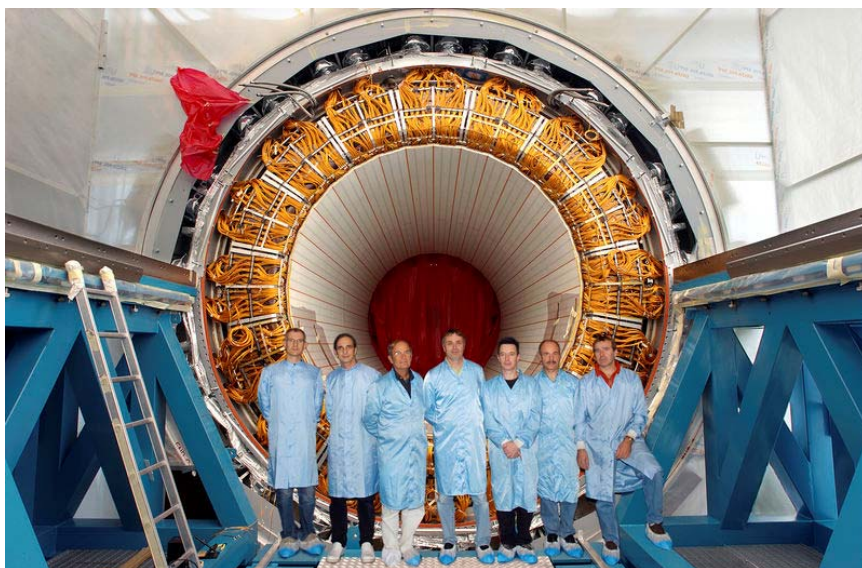

# The ATLAS Barrel Cryostat Installation

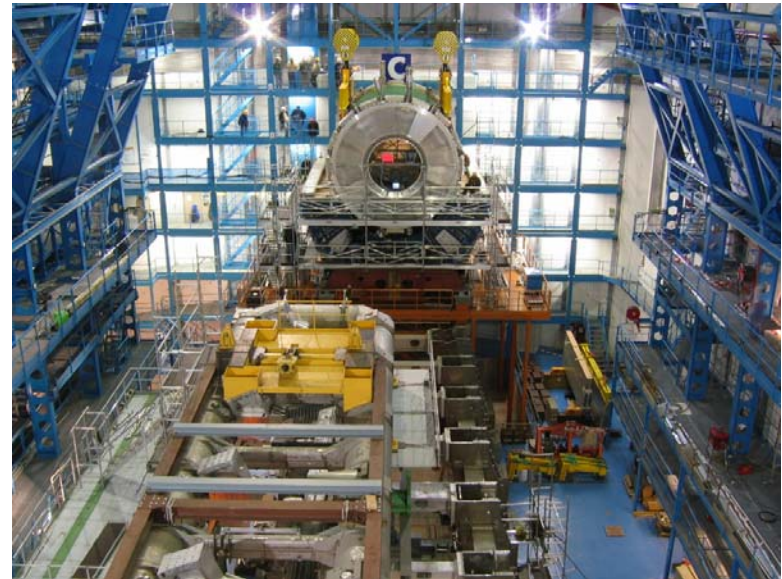
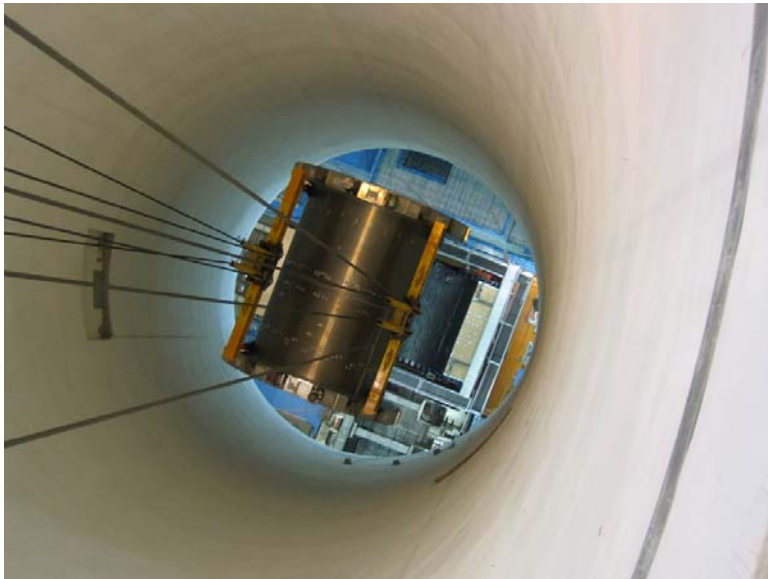

# LAr Calorimeter Readout Electronics

---

- At Columbia, we have designed and are starting production of the readout electronics for the ATLAS LAr calorimeters

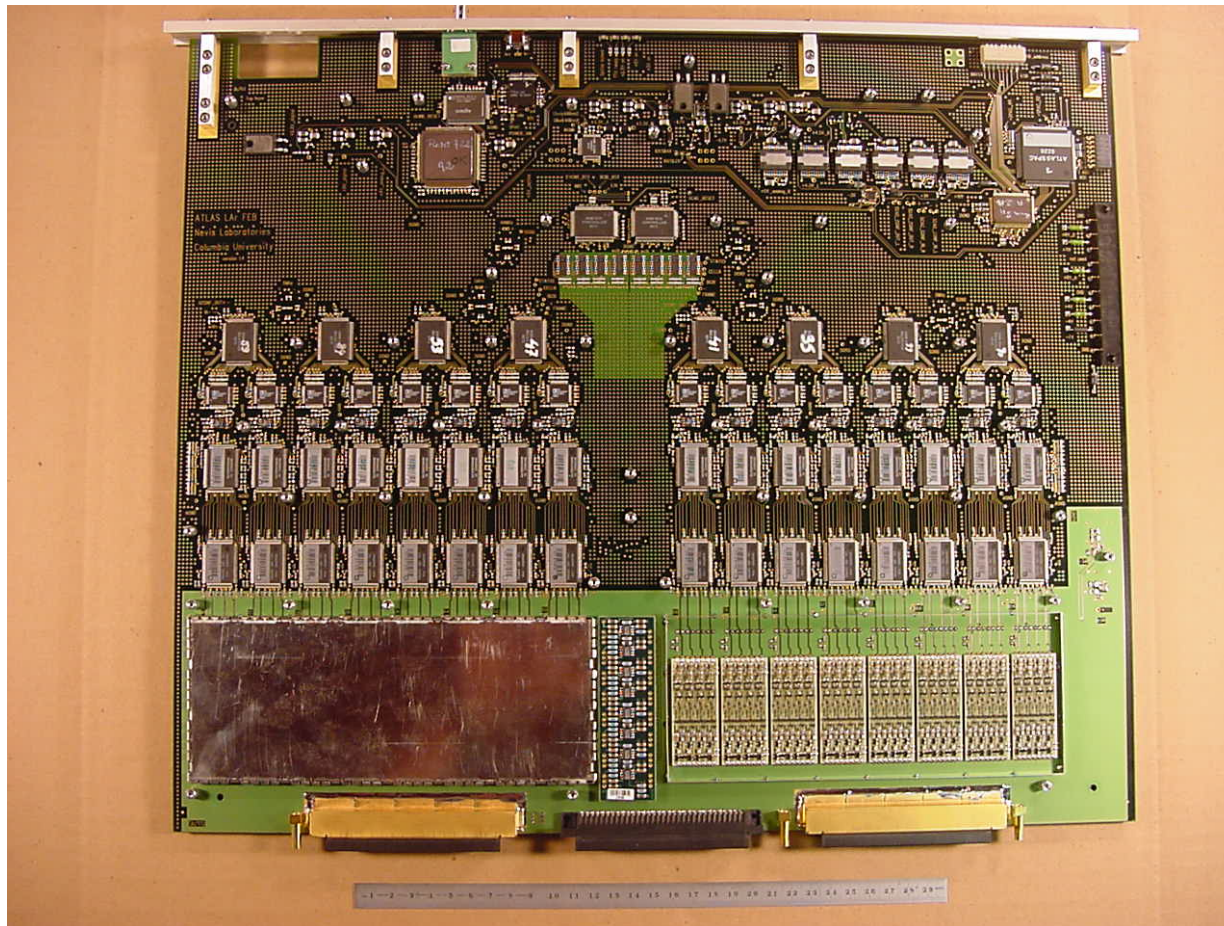

## Requirements of ATLAS LAr Readout

---

- read out  $\approx 170\text{k}$  channels of calorimeter
- dynamic range  $\approx 16$  bits
- measure signals at bunch crossing frequency of  $40\text{ MHz}$  (ie. every  $25\text{ ns}$ )
- store signals during L1 trigger latency of  $\approx 2.5\ \mu\text{s}$  (100 bunch crossings)
- digitize and read out  $5$  samples/channel at L1 rate of  $\approx 100\text{ kHz}$
  
- measure deposited energies with resolution  $< 0.25\%$
- measure times of energy depositions with resolution  $\ll 25\text{ ns}$
  
- high density (128 channels per board)
- low power ( $\approx 0.8\text{ W/channel}$ )
- high reliability over expected lifetime of  $> 10$  years
- for on-detector electronics, be tolerant of significant levels of radiation due to intense particle collisions

## Overview of ATLAS LAr calorimeter frontend board (FEB)

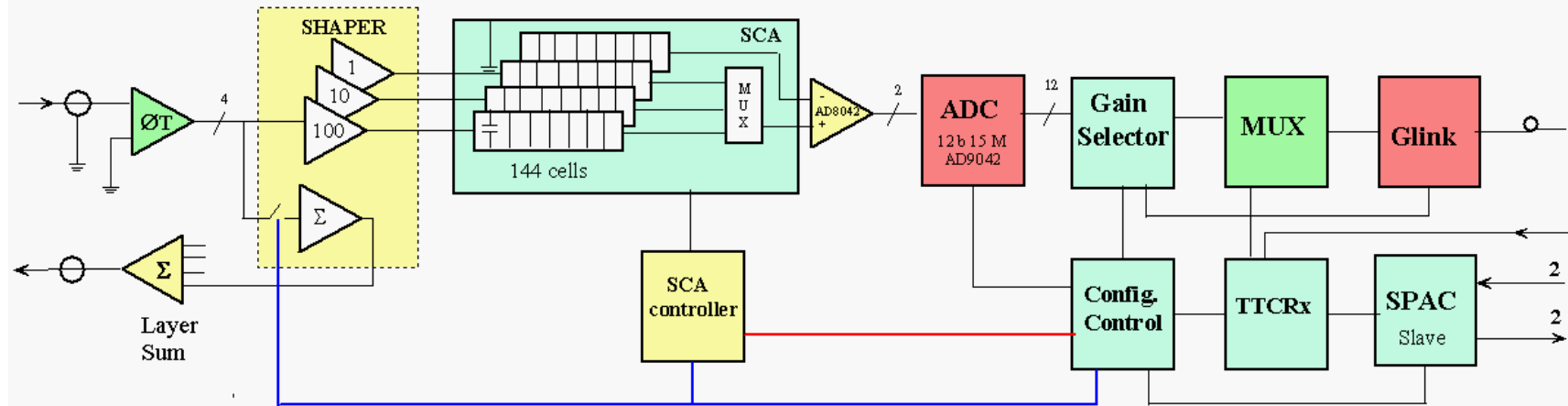

### ■ functionality includes:

- receive input signals from calorimeter
- amplify and shape them
- store signals in analog form while awaiting L1 trigger
- digitize signals for triggered events
- transmit output data bit-serially over 1.6 Gbps optical link off detector

# Overview of main FEB components

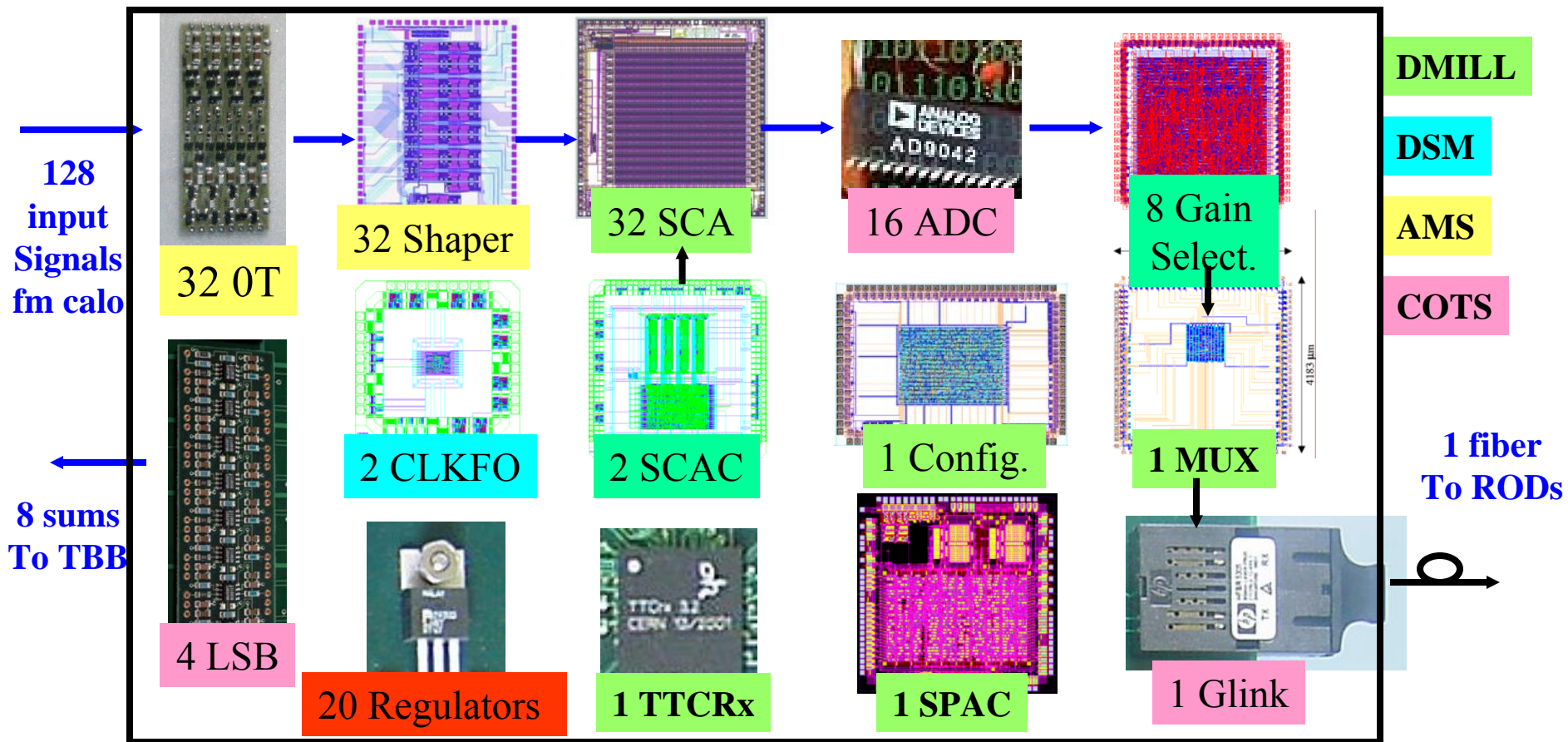

# FEB Prototype Results

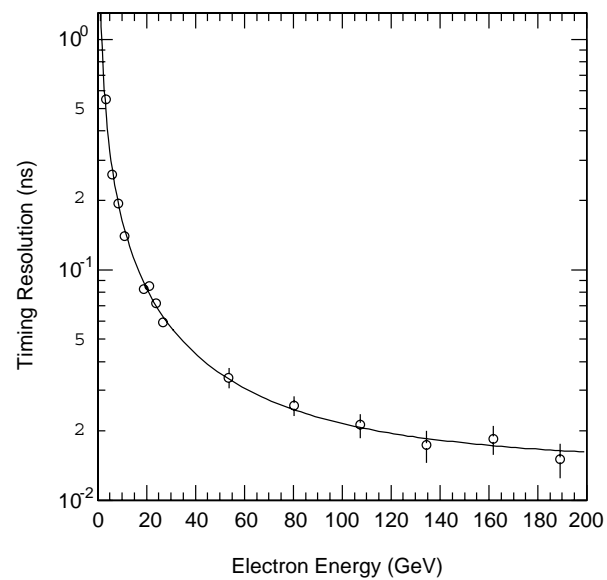
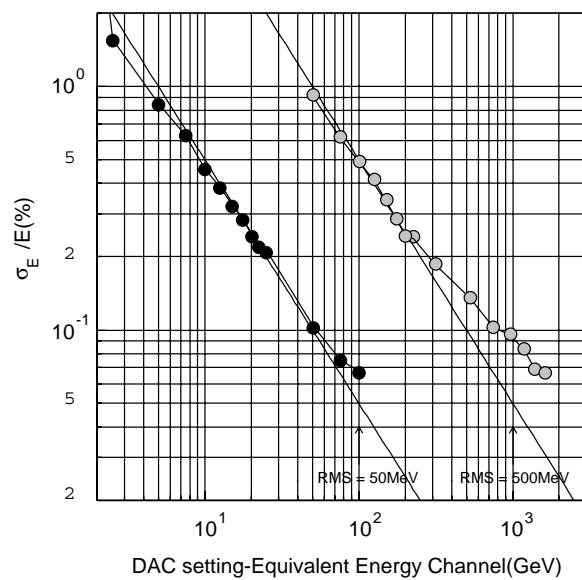
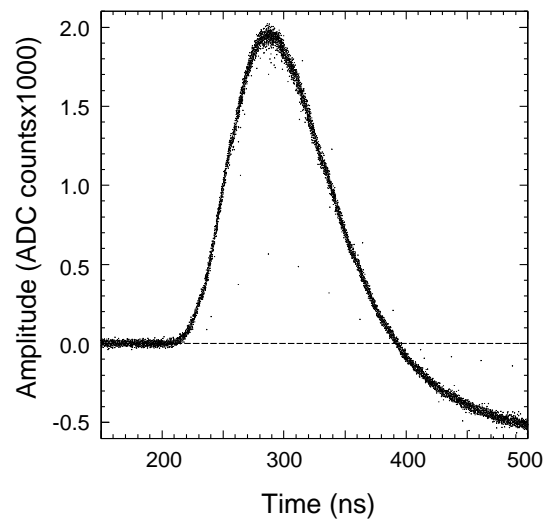

# ATLAS Tile Hadronic Calorimeter

$$\frac{\sigma(E)}{E} \approx \frac{30\%}{\sqrt{E}} \oplus 3\%$$

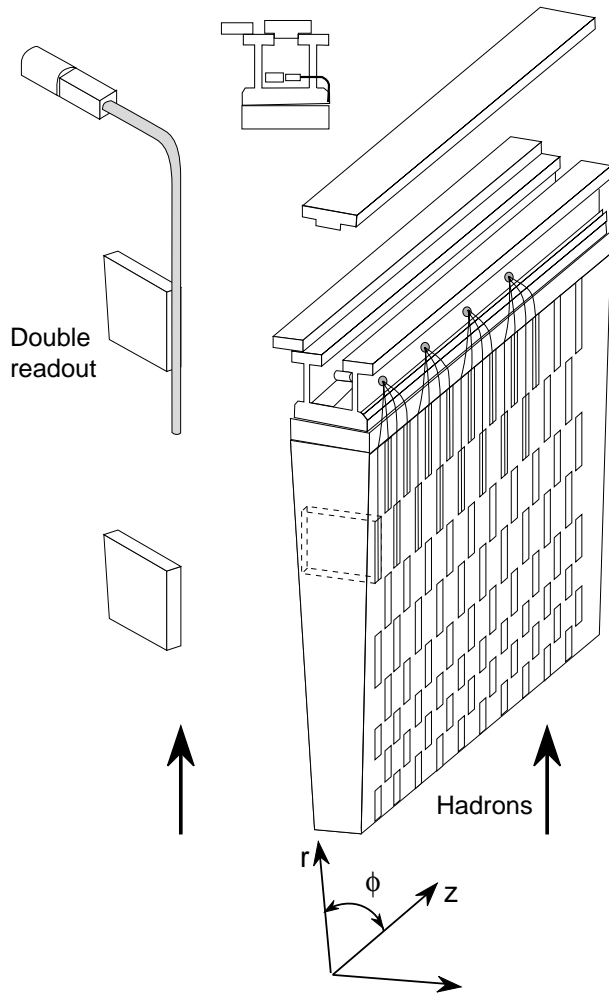

# ATLAS Calorimetry Depth and Missing $E_T$

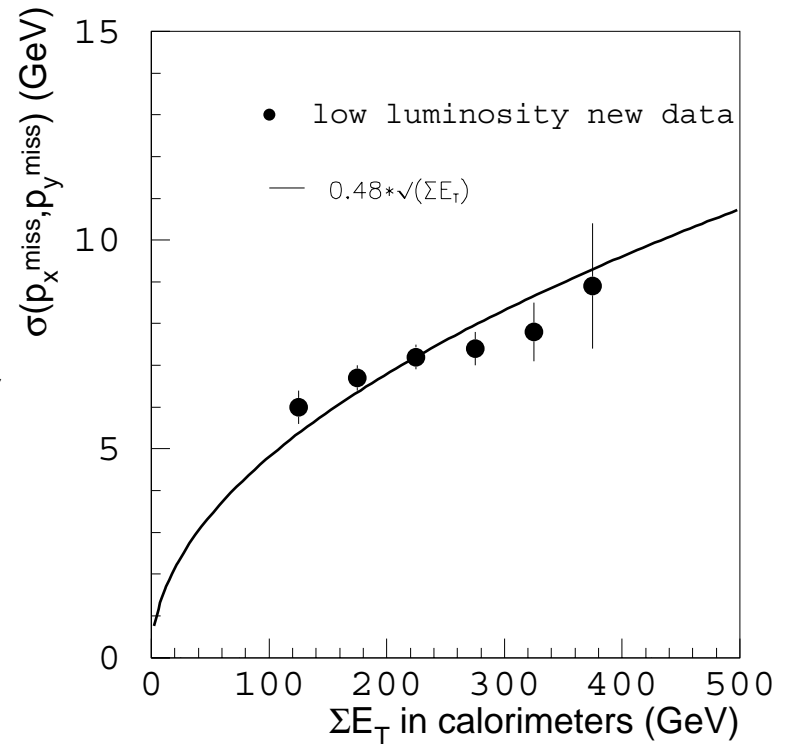
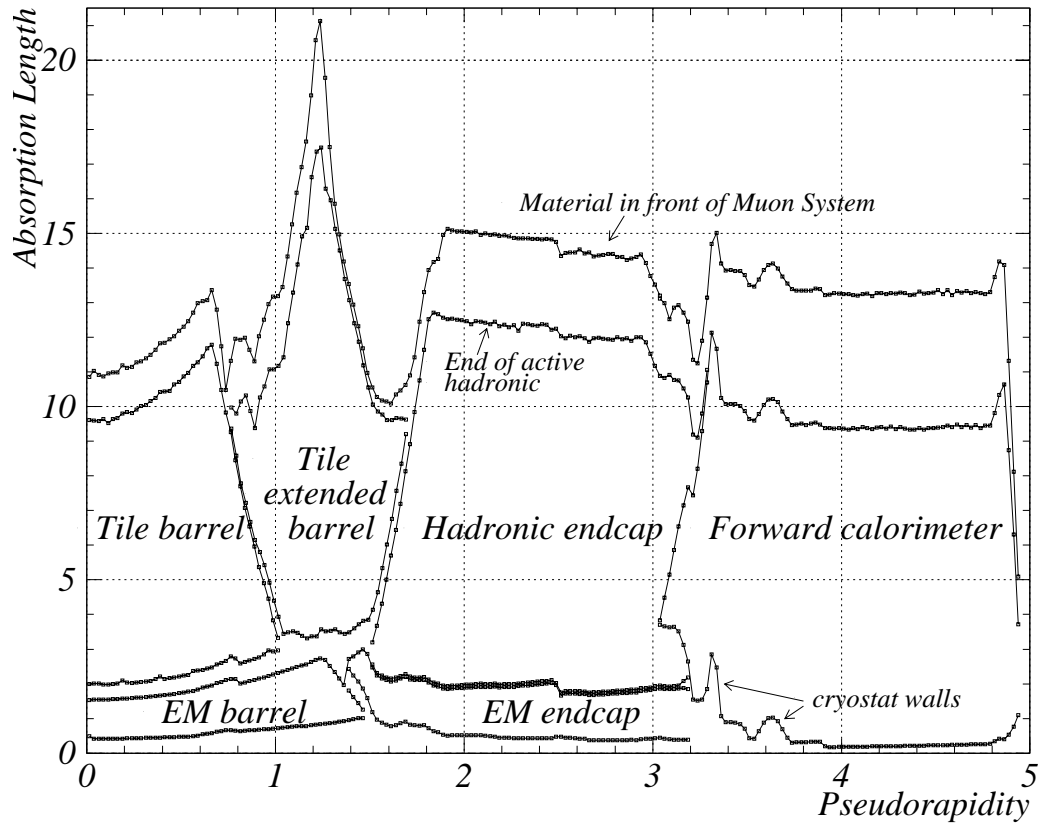

# ATLAS Toroidal Muon Spectrometer

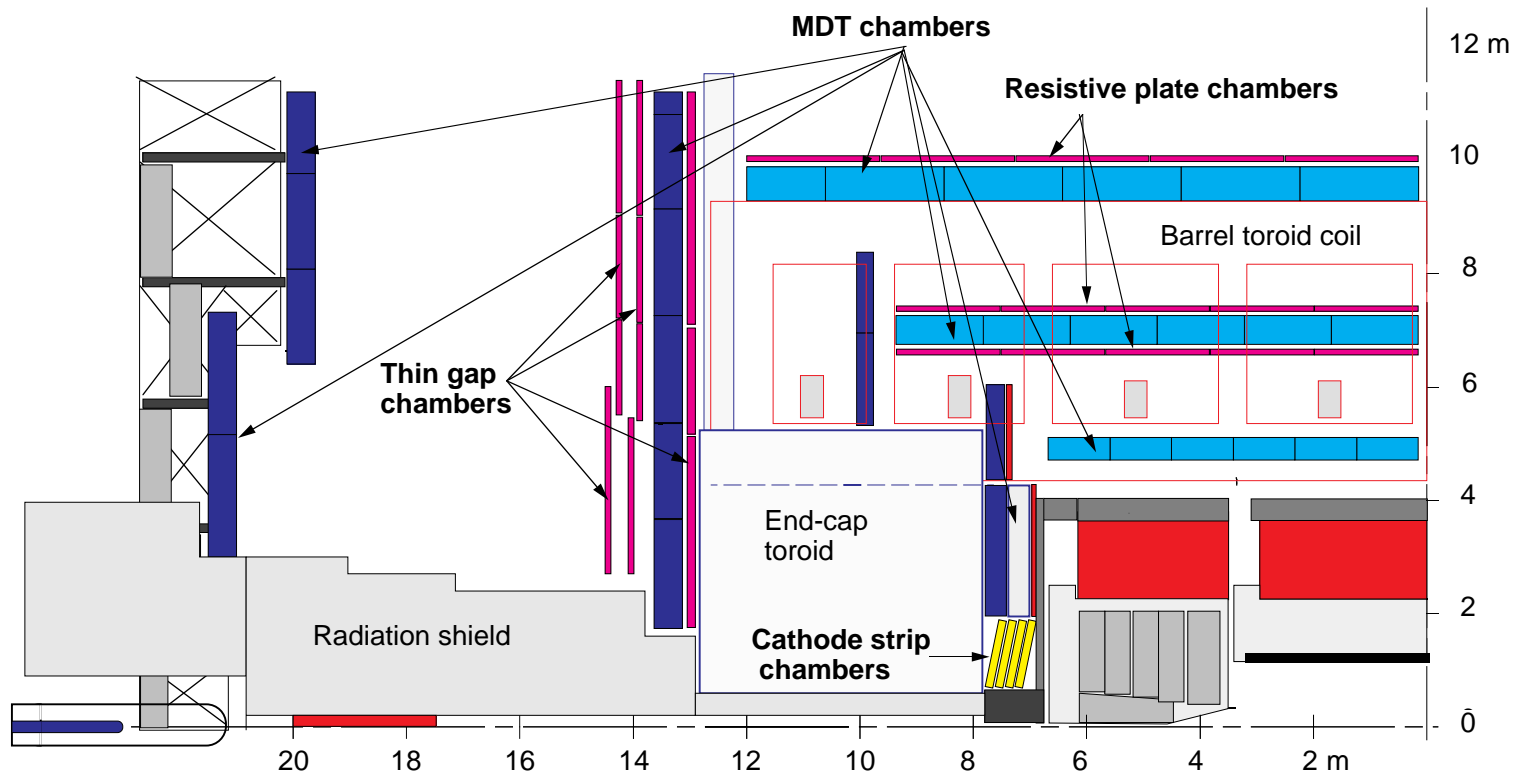

- 3 superlayers of tracking chambers (**370k drift tubes, 67k CSC**) and trigger chambers (**355k RPC, 440k TGC**)
- total detector area **> 12k m<sup>2</sup>**
- toroidal magnetic field provided by array of air-core toroids

# ATLAS Muon Detectors



# ATLAS Toroidal Magnet System

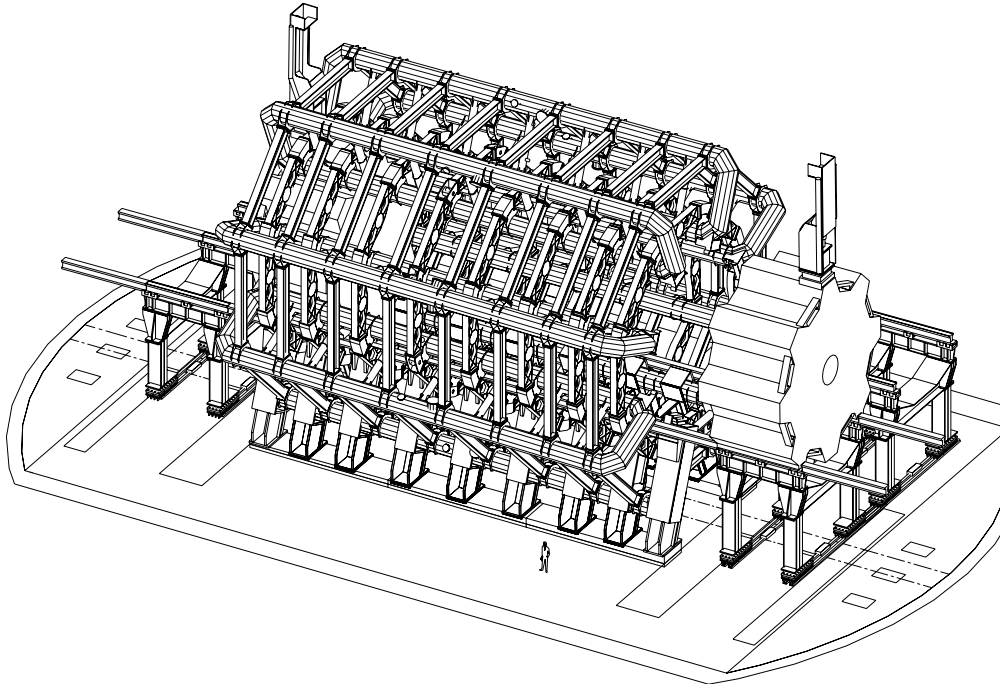

- **170 t (90 km) superconductor, 700 t cold mass**
- **total stored energy 1.55 GJ**

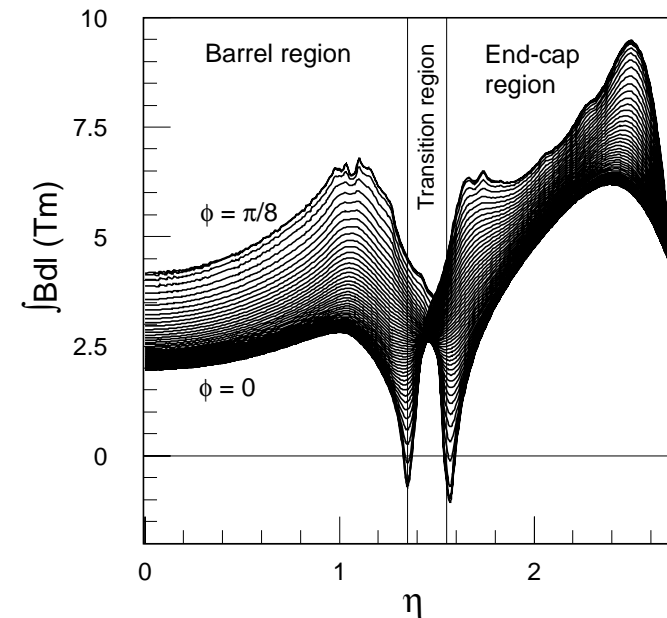

# ATLAS Barrel Toroid Installation

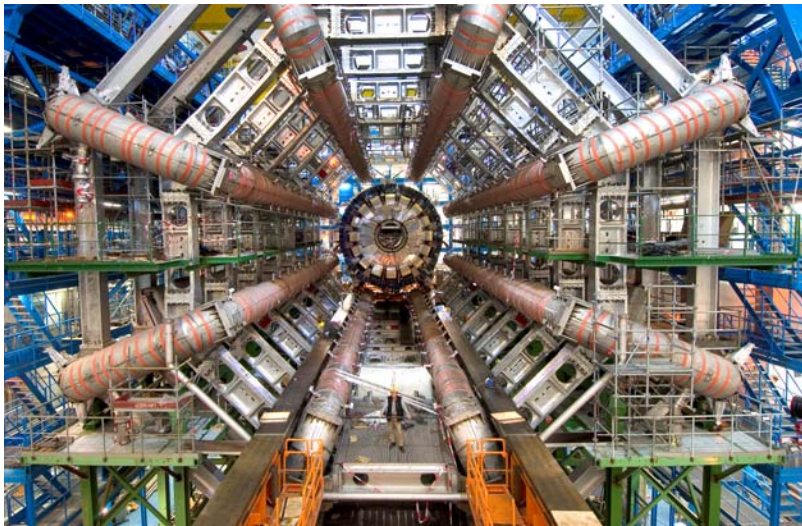

# ATLAS Endcap Toroids

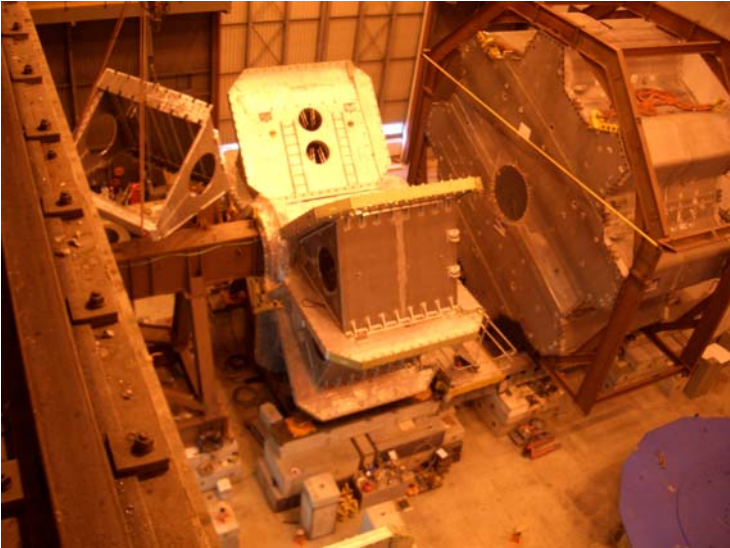
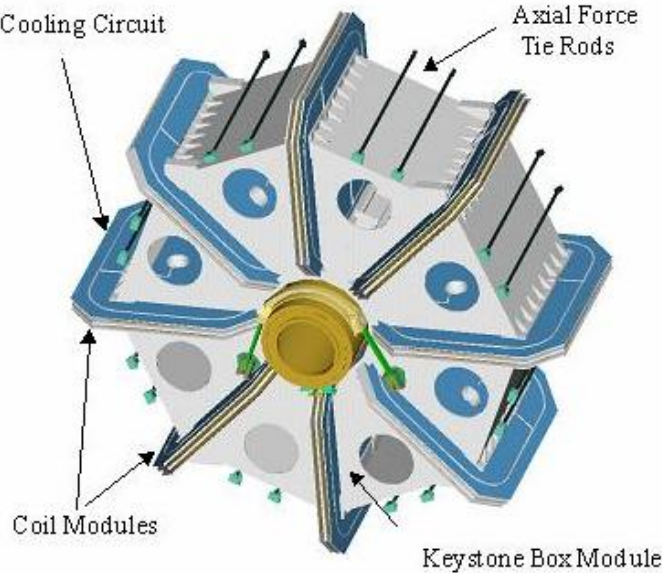

# ATLAS Muon Momentum Resolution

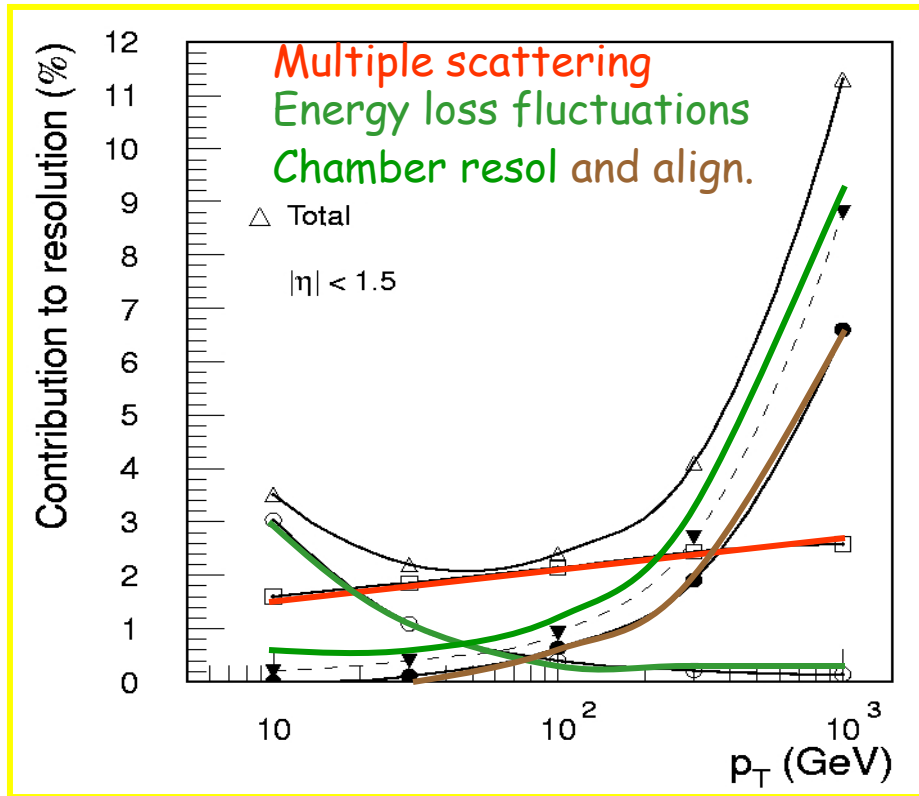

The muon spectrometer resolution dominates for  $p_T > 100 \text{ GeV}/c$

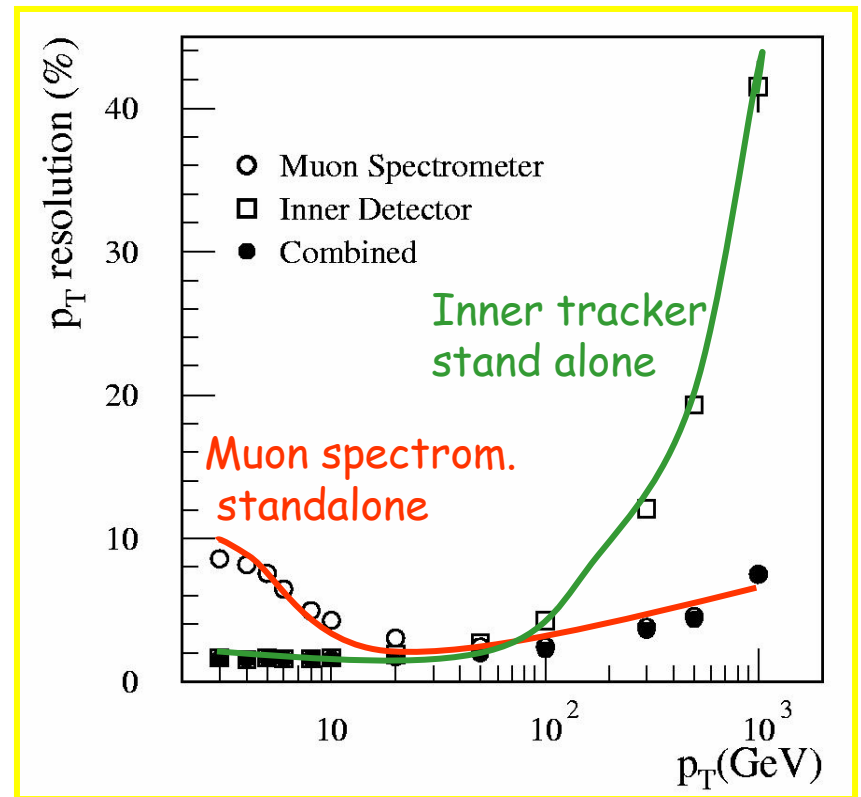

# ATLAS Status Today

Follow progress on Webcams at

[http://atlaseye-webpub.web.cern.ch/atlaseye-webpub/web-sites/pages/UX15\\_webcams.htm](http://atlaseye-webpub.web.cern.ch/atlaseye-webpub/web-sites/pages/UX15_webcams.htm)

